

# ERECTA STEP

MODULAR PLATFORMS AND STAIRS

Safety made Simple.



# RollAStep

MOBILE ROLLING WORK PLATFORMS

Designed for Work. Built for Safety.



# PERFECTA STEP

CUSTOMIZED INDUSTRIAL STAIRS AND WORK PLATFORMS

Perfection made Perfect.



# YellowGate



One Gate. Fits All. Stops Falls.

# 5 Main Components

Unlimited Configurations

1  
HANDRAILS



2  
UNIVERSAL  
PLATFORM



3  
LADDER  
UNITS



4  
SAFETY  
STAIRS



## Bolts Together

All components share the same bolt hole patterns to reduce parts and erection time. No welding or fabrication is required to construct any configuration.



5  
TOWER  
SUPPORTS



## Why buy ErectaStep?

- 1. Completely Universal** – design for your custom needs – allows for units to be repurposed later in different configurations.
- 2. Pre-engineered components** – you save custom engineering costs.
- 3. Safety compliance built into the product** – Lowers your risk of ownership and increases safety.
- 4. Costs less than custom fabrication.**
- 5. In stock and ready to ship!**

# Crossovers

E-2

## Safety made simple.

The ErectaStep system is ideal for crossovers which allow safe and easy access over pipes, dike walls and other obstructions. ErectaStep provides up to 9' (2743 mm) of horizontal clearance without tower supports (three platforms) or infinite horizontal clearance with tower supports. To design your crossover, measure your vertical and horizontal clearance and refer to the chart on the last page of this catalog to determine which stair model and how many modular platforms you will need. If you ever have any questions, please feel free to call one of our experienced customer service representatives or send us a picture of your work area so we can design the crossover that will best suit your needs.



Each component is proudly crafted in our South Carolina facility.



### Crossover Configuration Example 1

**PARTS USED:** 2 STAIR UNITS (11389),  
2 HANDRAILS (11395), 1 PLATFORM (11394)

This configuration provides 3' (914 mm) horizontal and 39" (991 mm) vertical clearance.

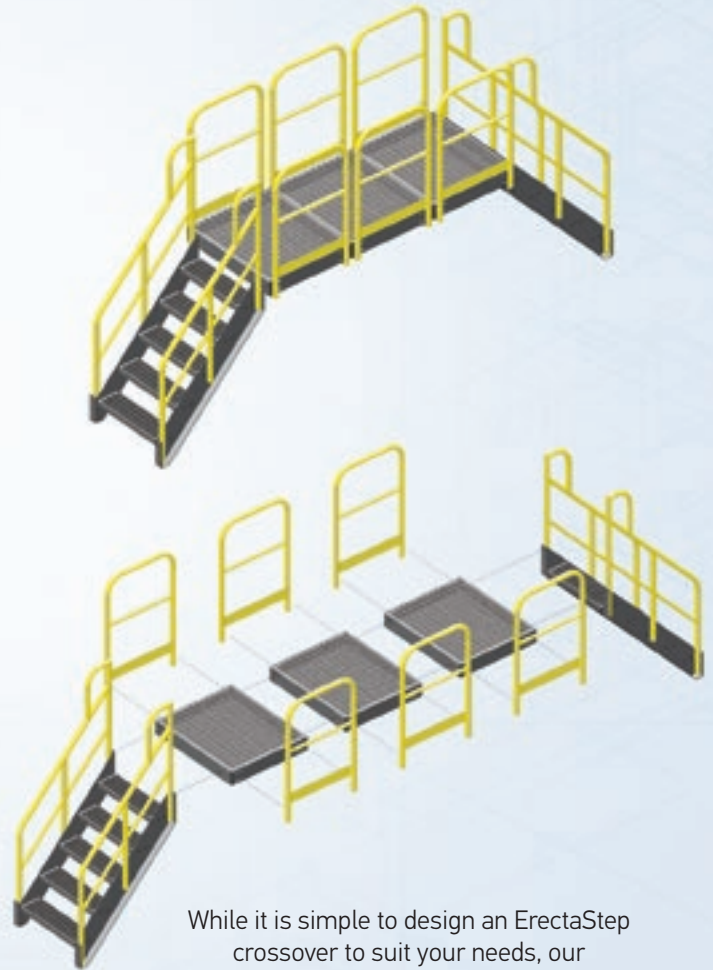

While it is simple to design an ErectaStep crossover to suit your needs, our customer service representatives are available to help with your design by providing real time engineering drawings.



#### ^ Crossover Configuration Example 2

**PARTS USED:** 2 STAIR UNITS (11390),  
4 HANDRAILS (11395), 2 PLATFORMS (11394)

This configuration provides 6' (1829 mm) horizontal  
and 48" (1219 mm) of vertical clearance.



#### ^ Crossover Configuration Example 3

**PARTS USED:** 2 STAIR UNITS (11387),  
6 HANDRAILS (11395), 3 PLATFORMS (11394)

This configuration provides 9' (2743 mm) horizontal  
and 21" (533 mm) of vertical clearance.

# Example Configurations

E-4

## Limitless designs.

Configurations are endless and limited only by your imagination. Call us for any assistance.



Each component is proudly crafted in our South Carolina facility.



### Example Configuration 1

**PARTS USED:** 2 STAIR UNITS (11388), 2 PLATFORMS (11394), 5 HANDRAILS (11395), 1 6/TOWER (11383), 1 3/TOWER (11380)

This work platform system allows specific access to parts such as valves or filters, that require repeated access.



### Example Configuration 2

**PARTS USED:** 2 STAIR UNITS (11388), 3 PLATFORMS (11394), 6 HANDRAILS (11395), 2 TOWERS (11380)

This "L" shaped crossover configuration allows for safe and easy travel over areas such as assembly lines.



## MANUFACTURED USING PRECISION LASER TECHNOLOGY

### Example Configuration 3 ▾

**PARTS USED:** 1 1-STEP STAIR UNIT (11386),  
1 3-STEP STAIR UNIT (11388), 1 4-STEP  
STAIR UNIT (11389), 6 PLATFORMS (11394),  
13 HANDRAILS (11395), 2 1/TOWERS (11378),  
2 5/TOWERS (11382), 2 7/TOWERS (11384)

This platform provides safe access to upper levels within a confined space, such as the mezzanine level of a warehouse.

### Example Configuration 4 ▶

**PARTS USED:** 1 STAIR UNIT (11388),  
1 PLATFORM (11394), 3 HANDRAILS  
(11395), 1 TOWER (11380)

This small platform allows for easy, permanent access to elevated work areas – a safe replacement for wobbly ladders, work stands or footstools.



# Example Configurations

E-6

## Limitless designs.

Configurations are endless and limited only by your imagination. Call us for any assistance.



Each component is proudly crafted in our South Carolina facility.

Multiple tiers of varying heights require no engineering or supplemental components and can be assembled in any configuration imaginable.

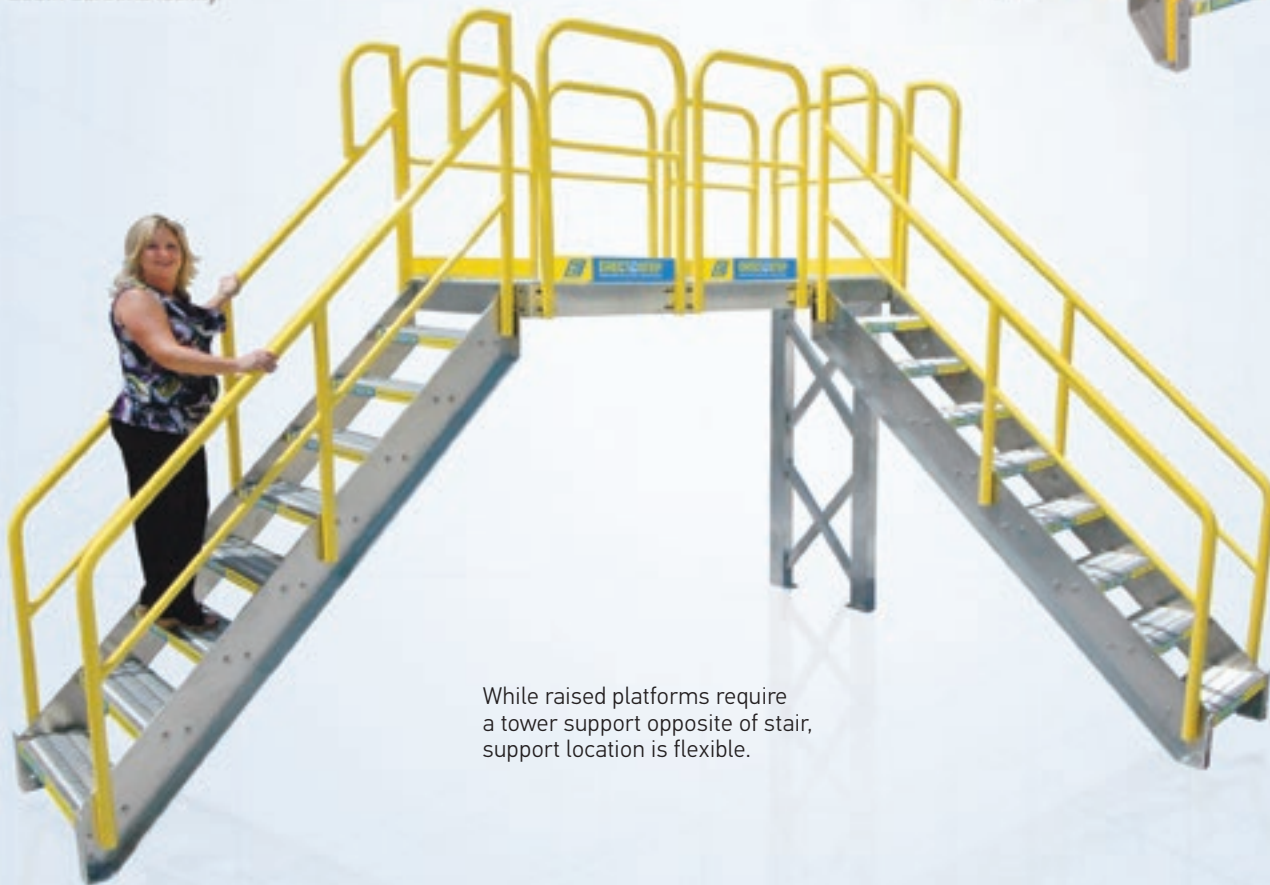

While raised platforms require a tower support opposite of stair, support location is flexible.





## MANUFACTURED USING PRECISION LASER TECHNOLOGY

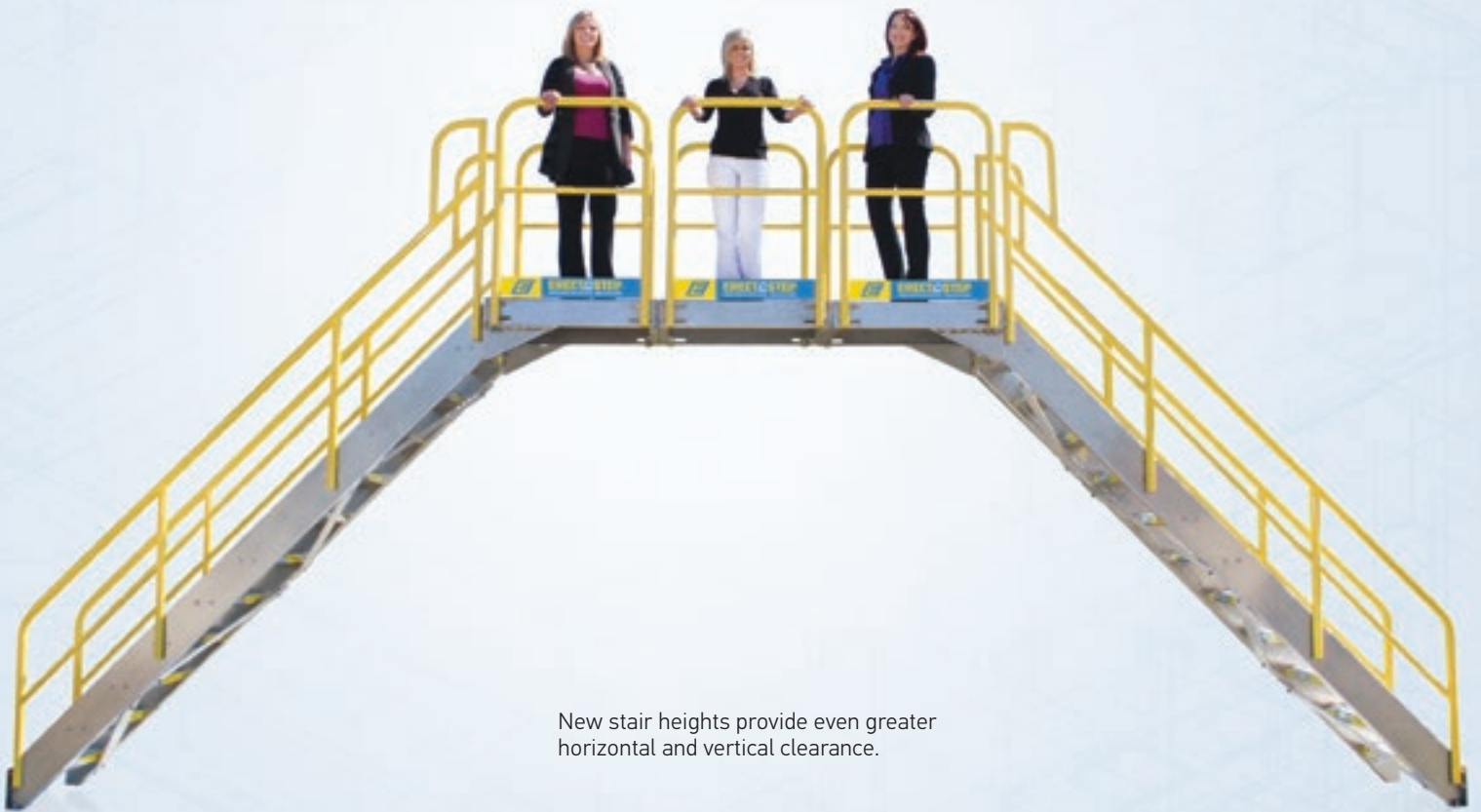

New stair heights provide even greater horizontal and vertical clearance.

# Example Configurations

E-8

## 90° Multi-directional Conveyor Crossover

**PARTS USED:** 2 8-STEP STAIR UNITS (11939), 1 UNIVERSAL PLATFORM (11394), 1 8-TOWER SUPPORT (11385), 2 SAFETY HANDRAIL (11935)



## Maintenance Access Platform

**PARTS USED:** 2 3-STEP STAIR UNITS (11388), 2 UNIVERSAL PLATFORMS (11394), 5 SAFETY HANDRAILS (11395), 1 6-TOWER SUPPORT (11383), 1 3-TOWER SUPPORT (11380)



# Ladder Configurations

E-9

## Built for strength.

Our ladder components are available in eleven sizes, from one to eleven steps and bolt to the bottom of any ErectaStep platform with no supplemental parts or engineering. Each ladder also functions as a support tower. ANSI yellow powder coating on handrails meet OSHA safety requirements and provide a durable finish.



Each component is proudly crafted in our South Carolina facility.



**MANUFACTURED  
USING PRECISION  
LASER TECHNOLOGY**

The Ladder Component provides greater flexibility when providing access to elevated platforms.

# PerfectAStep

E-10

## Make your platform a perfect fit.

Custom engineered modular parts can make any project a perfect fit, when you need it. With the limitless configurations you can design the perfect system to fit your needs. Contact our team for additional design and configuration needs.



**MANUFACTURED USING  
PRECISION LASER TECHNOLOGY**



Custom precision cut modular pieces to fit any project.



Perfect fit modular designs to fit all projects large or small.



Custom width stairs for easy platform access.



Custom pieces for easy access and employees' safety.



Each component is proudly crafted in our South Carolina facility.

# Universal Platform Design

E-12

## Customization is king.

ErectaStep's universal 3' x 3' (914 mm x 914 mm) platform design is infinitely expandable through common bolt hole patterns found on each side of the platform. Attaching platforms, stairs or ladders is accomplished with only a ratchet and an open-ended wrench. No additional support is required for spans of 9' (2743 mm) (3 platforms). When joining more than 4 platforms tower supports are required and bolt easily to the bottom of one or multiple platforms, regardless of stair location. Platforms feature a stamped, slip resistant surface which provides solid traction. Each platform is manufactured with stamping technology to increase strength and lower costs by eliminating welds. Our use of robotic welding for the few remaining joints results in strong, precise welds on every platform shipped.



Each component is proudly crafted in our South Carolina facility.

► **DESIGN LOAD:**  
**50 PSF (244 KGF/M2)**

**PATENT PENDING**

Universal Platform Unit PART NO. 11394

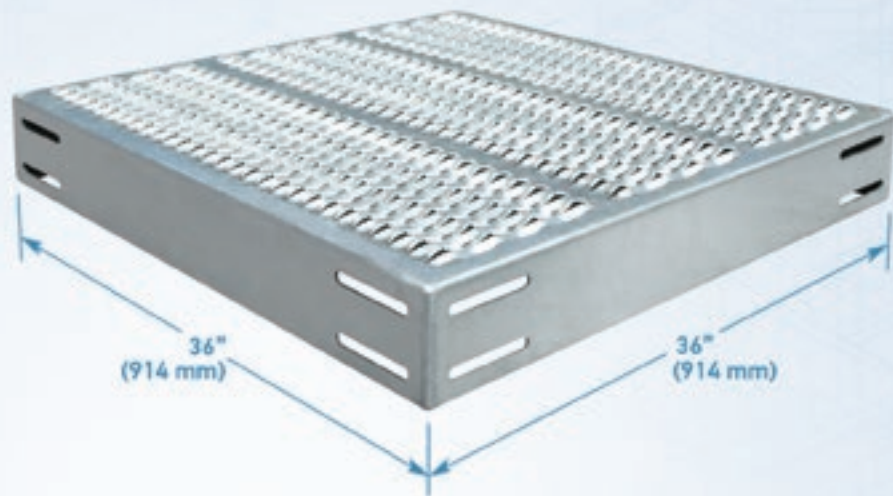

**PLATFORM IS IDENTICAL ON ALL 4 SIDES**

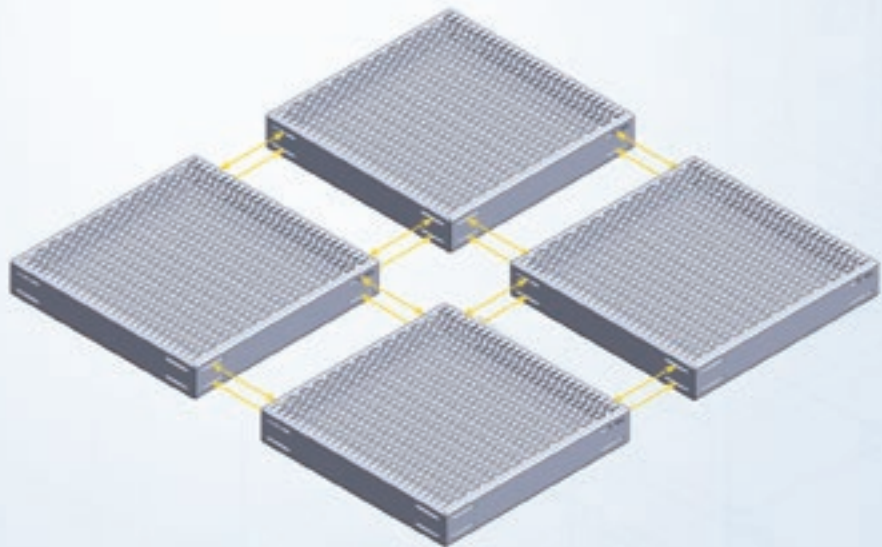

**PLATFORMS EASILY BOLT TOGETHER  
TO MAKE A LARGER PLATFORM**



## MANUFACTURED USING PRECISION LASER TECHNOLOGY

3' x 12' (914 mm x 3658 mm)  
Platform Configuration

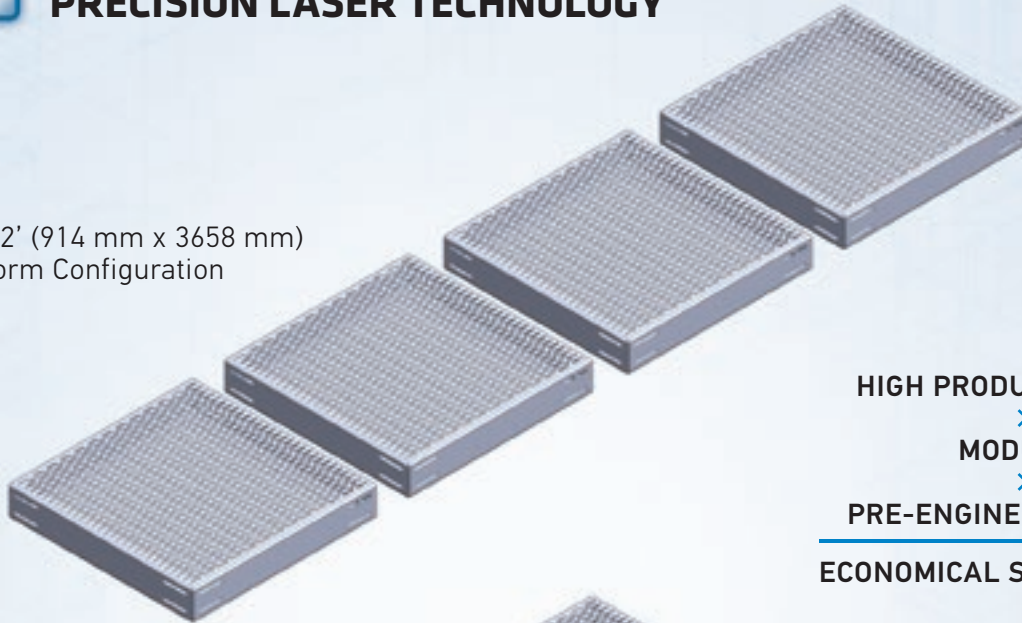

HIGH PRODUCTION RUNS  
×  
MODULAR  
×  
PRE-ENGINEERED DESIGN  

---

ECONOMICAL SAVINGS TO YOU

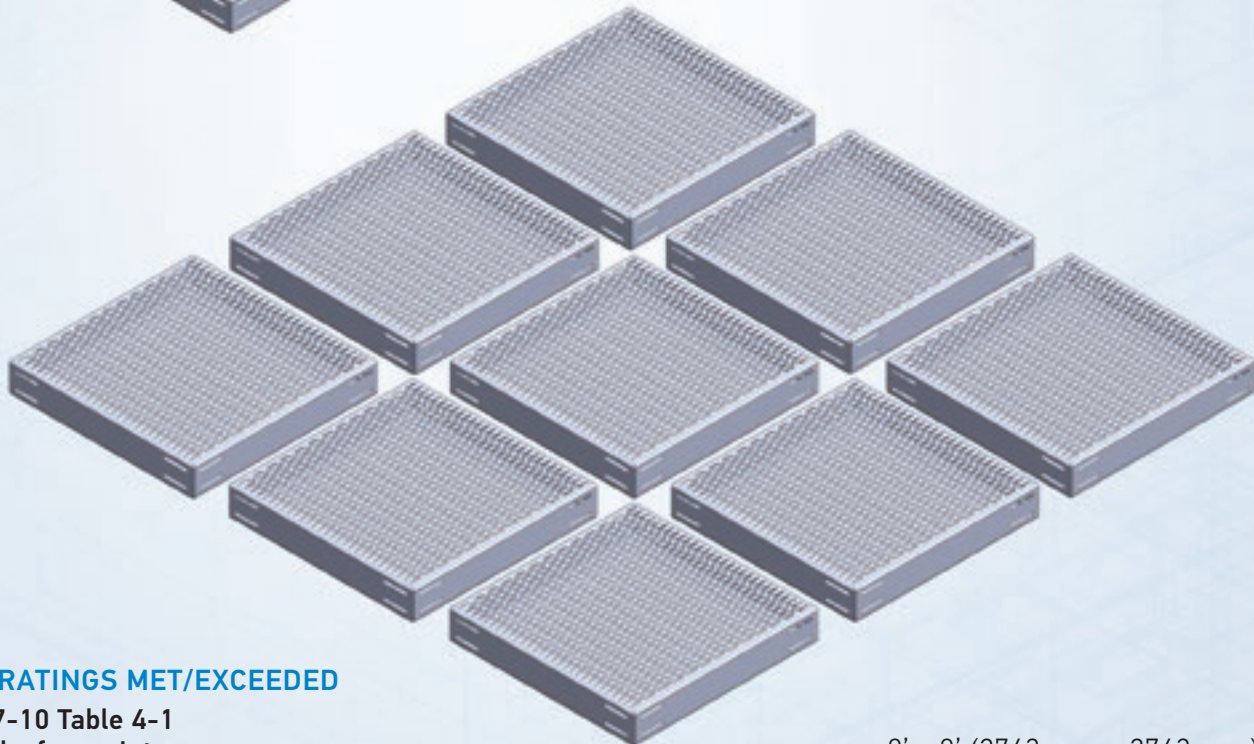

### CODE RATINGS MET/EXCEEDED

ASCE 7-10 Table 4-1  
Catwalks for maintenance access  
= 40 PSF (195.3 kgf/m<sup>2</sup>)

9' x 9' (2743 mm x 2743 mm)  
Platform Configuration

# Safety Handrails

E-14

## Ease of use.

ErectaStep Safety Handrails come in one standardized size and share a bolt hole pattern with the universal platform, allowing the handrails to attach to any side of the platform. Constructed of round pipes with outer diameters of slightly less than 2" (51 mm) and powder coated ANSI safety yellow, these handrails are robust in strength as well as appearance.



Each component is proudly crafted in our South Carolina facility.

**PATENT PENDING**



**Safety Handrail** PART NO. 11395



Three handrail sections shown on each side of this crossover unit bolt up consecutively to their respective platforms, allowing for safe passage over workplace obstructions.



**HANDRAILS AND STAIRS SHARE  
THE SAME BOLT HOLE PATTERN**

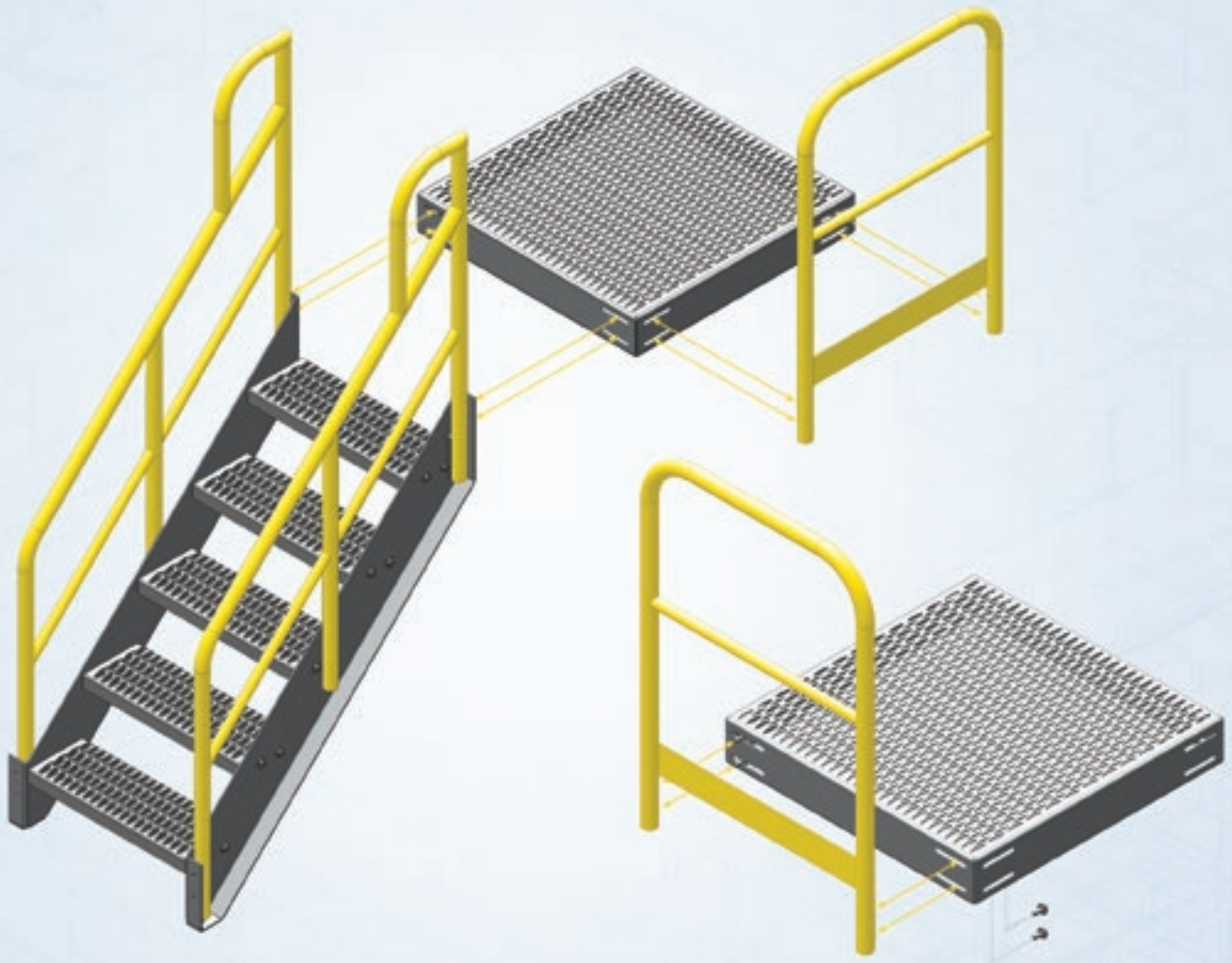

- ▶ **DESIGN LOAD:  
200 LBS. (91 KG) IN ANY DIRECTION**

# Safety Stairs

E-16

## A step up in quality.

ErectaStep stair units come in 9" (229 mm) vertical increments with 26" (660 mm) of walk surface and slip resistant tread. To meet OSHA regulations, handrails are powder coated ANSI safety yellow. Stairs bolt to any side of the universal platform, allowing for easy customization. Stair units ship broken down for low shipping costs and are easy to assemble. Please see the spec sheet on page E-30 for dimensions on all stair sizes.

**PATENT PENDING**



**1-Step Safety Stair**  
Part No. 11386



**2-Step Safety Stair**  
Part No. 11387



**3-Step Safety Stair**  
Part No. 11388



**4-Step Safety Stair**  
Part No. 11389



**5-Step Safety Stair**  
Part No. 11390



**6-Step Safety Stair**  
Part No. 11391



**7-Step Safety Stair**  
Part No. 11392



Each component is proudly crafted in our South Carolina facility.

▶ **DESIGN LOAD:  
1000 LBS. (454 KG) MOVING LOAD**

**STAIR BOLTS TO ANY OF THE 4 SIDES  
OF THE UNIVERSAL PLATFORM**



**8-Step Safety Stair**  
Part No. 11393

**9-Step Safety Stair**  
Part No. 11465

**10-Step Safety Stair**  
Part No. 11466

**11-Step Safety Stair**  
Part No. 11467

# Tower Supports

E-18

## Built for strength.

ErectaStep support towers use an anchor bolt hole design that match up with the bolt-hole pattern on the bottom of the universal platform, allowing for three bolt-up scenarios: 1) a single tower bolting to a single platform; 2) bolting two platforms on either side of a support tower; and 3) bolting support towers on multiple sides of the same platform. Support towers are necessary when using more than 3 platforms in succession. Each leg of support must be supported to grade adequately.

**PATENT PENDING**



Each component is proudly crafted in our South Carolina facility.

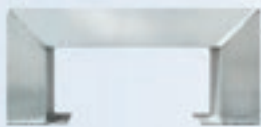

**Tower Support 1**  
Part No. 11378



**Tower Support 2**  
Part No. 11379



**Tower Support 3**  
Part No. 11380



**Tower Support 4**  
Part No. 11381



**Tower Support 5**  
Part No. 11382



**Tower Support 6**  
Part No. 11383



**Tower Support 7**  
Part No. 11384



**MANUFACTURED USING  
PRECISION LASER TECHNOLOGY**



**Tower Support 8**  
Part No. 11385



**Tower Support 9**  
Part No. 11468



**Tower Support 10**  
Part No. 11469



**Tower Support 11**  
Part No. 11470

# Ladder Units

E-20

## Versatility defined.

Our ladder components are available in eleven sizes, from one to eleven steps and bolt to the bottom of any ErectaStep platform with no supplemental parts or engineering. Each ladder also functions as a support tower, including D-shaped rungs for added traction and ergonomics. ANSI yellow powder coating on handrails meet OSHA safety requirements and provide a durable finish.

**PATENT PENDING**



**1-Step Ladder Unit**  
Part No. 11457



**2-Step Ladder Unit**  
Part No. 11458



**3-Step Ladder Unit**  
Part No. 11459



**4-Step Ladder Unit**  
Part No. 11460



**5-Step Ladder Unit**  
Part No. 11461



**6-Step Ladder Unit**  
Part No. 11462



**7-Step Ladder Unit**  
Part No. 11463



**MANUFACTURED USING  
PRECISION LASER TECHNOLOGY**



Each component is proudly crafted in our South Carolina facility.



**8-Step Ladder Unit**  
Part No. 11464



**9-Step Ladder Unit**  
Part No. 11488



**10-Step Ladder Unit**  
Part No. 11489



**11-Step Ladder Unit**  
Part No. 11490

# Application Examples

E-22

ErectaStep is ideal for creating crossovers, raised walkways, equipment access and service platforms.



Safe valve access.



Safely cross containment walls.



Changing these industrial filters has never been safer.



Safely cross numerous different size piping at this gas compressor station.





Easily access these valves from all sides.

# Application Examples

E-24

ErectaStep is ideal for creating crossovers, raised walkways, equipment access and service platforms.



Work safely on all four sides of this conveyor motor at this power generation station.



Crossing rooftop HVAC ductwork safely without damage to the lines.



Large oil pipeline cross over.



Aluminum crossover withstands the toughest climates.



Avoid slips, trips and falls on busy rooftops.

# Application Examples

E-26

ErectaStep is ideal for creating crossovers, raised walkways, equipment access and service platforms.



Cross over with 26' (7925 mm) span.



Multi-level access with inspection platform.



Span 9' (2743 mm) of duct and piping with no intermediate support.



Span 9' (2743 mm) of conveyor with no intermediate support.



Brand new flagship distribution center crosses over 5000 ft (1524 m) of conveyer with all standard components.

# Application Examples

E-28

ErectaStep is ideal for creating crossovers, raised walkways, equipment access and service platforms.



Containment wall cross over.



Safely and efficiently access multiple valves.



Propane gas lines no longer a safety issue.



Access over and across multiple obstructions safely.



Safely access storage tanks in all weather conditions.

# Specifications

E-30

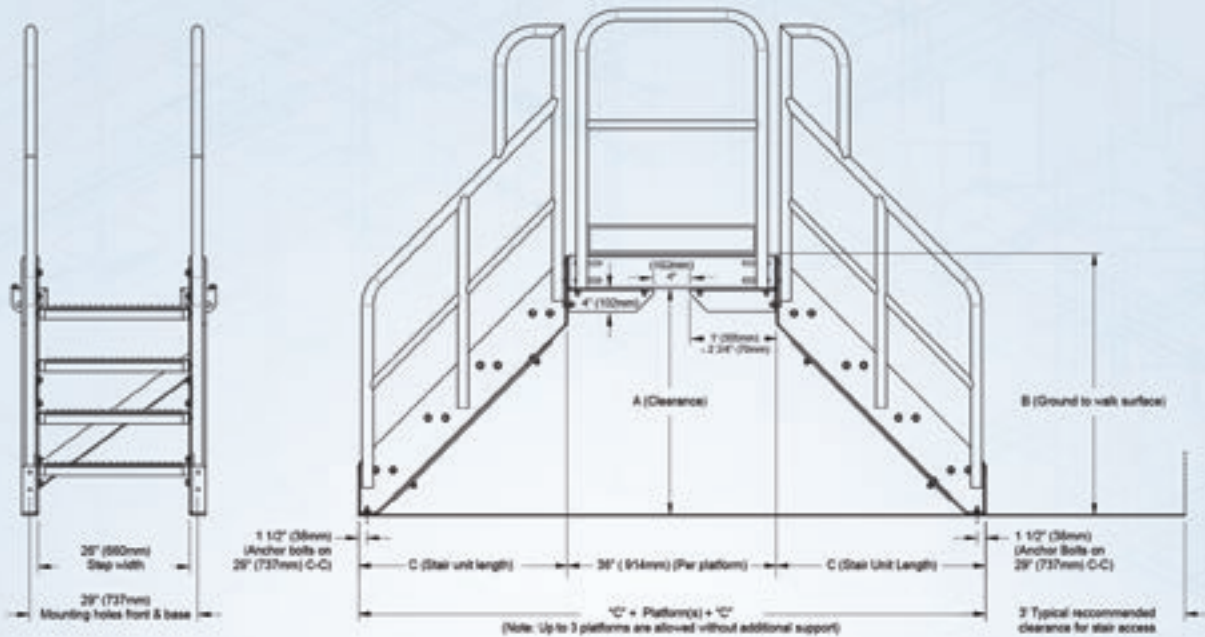

**Cross-Over Clearance Table**

	A (in) [mm]	B (in) [mm]	C (in) [mm]
1-Step	12 [305]	18 [457]	9 [229]
2-Step	21 [533]	27 [686]	18 [457]
3-Step	30 [762]	36 [914]	27 [686]
4-Step	39 [990]	45 [1143]	36 [914]
5-Step	48 [1219]	54 [1372]	45 [1143]
6-Step	57 [1447]	63 [1600]	54 [1372]
7-Step	66 [1676]	72 [1829]	63 [1600]
8-Step	75 [1905]	81 [2057]	72 [1829]
9-Step	84 [2134]	90 [2286]	81 [2057]
10-Step	93 [2362]	99 [2515]	90 [2286]
11-Step	102 [2591]	108 [2743]	99 [2515]

Please refer to nominal dimensions provided here. If any existing obstructions are critically close to the designed limit stated, please contact us for any clarifications to insure proper fit.

**Ladder Unit Specifications**

	A (in) [mm]	Est. Weight [kg]
1-Step	18 [457]	44 lbs. [20]
2-Step	27 [686]	50 lbs. [23]
3-Step	36 [914]	55 lbs. [25]
4-Step	45 [1143]	60 lbs. [27]
5-Step	54 [1372]	66 lbs. [30]
6-Step	63 [1600]	71 lbs. [32]
7-Step	72 [1829]	77 lbs. [35]
8-Step	81 [2057]	82 lbs. [37]
9-Step	90 [2286]	87 lbs. [39]
10-Step	99 [2515]	93 lbs. [42]
11-Step	108 [2743]	98 lbs. [44]

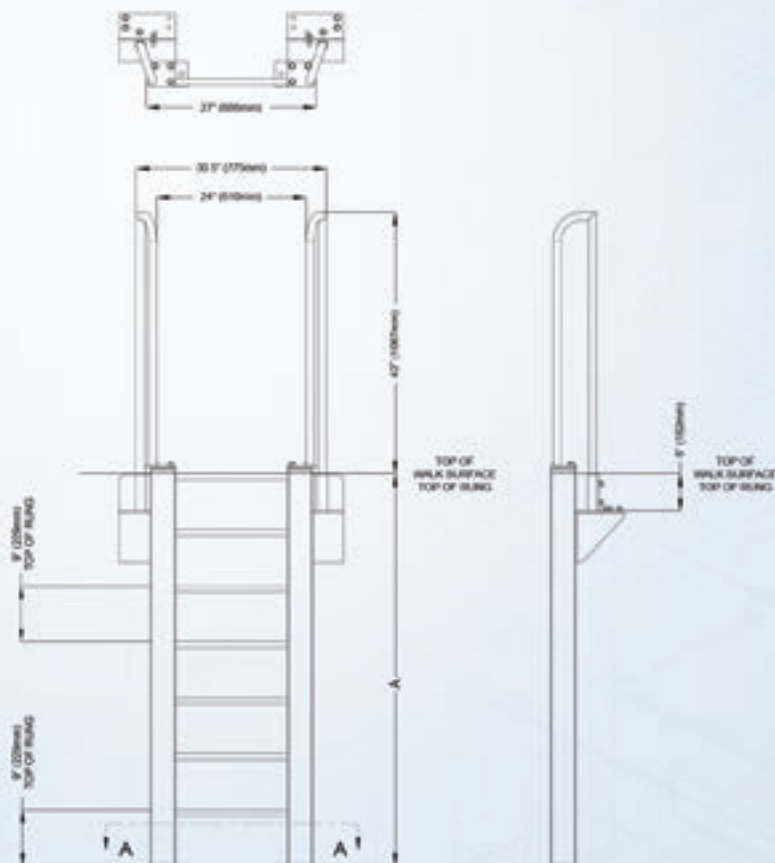



# OSHA Regulations/Terms and Conditions

## APPLICABLE OSHA REGULATIONS DESIGNED TO:

**OSHA 1910.23(e)(1)** A standard railing shall consist of top rail, intermediate rail, and posts, and shall have a vertical height of 42 inches [1067 mm] nominal from upper surface of top rail to floor, platform, runway, or ramp level. The top rail shall be smooth-surfaced throughout the length of the railing. The intermediate rail shall be approximately halfway between the top rail and the floor, platform, runway, or ramp. The ends of the rails shall not overhang the terminal posts except where such overhang does not constitute a projection hazard.

**OSHA 1910.23(e)(5)(iv)** The mounting of handrails shall be such that the completed structure is capable of withstanding a load of at least 200 lb [91 kg] applied in any direction at any point on the rail.

**OSHA 1910.23(e)(6)** All handrails and railings shall be provided with a clearance of not less than 3 inches [76mm] between the handrail or railing and any other object.

**OSHA 1910.23(e)(3)(ii)** For pipe railings, posts and top and intermediate railings shall be at least 1-1/2 [38mm] inches nominal diameter with posts spaced not more than 8 ft [2438 mm] on centers.

**OSHA 1910.23(e)(2)** A stair railing shall be of construction similar to a standard railing but the vertical height shall be not more than 34 inches [864 mm] nor less than 30 inches [762 mm] from upper surface of top rail to surface of tread in line with face of riser at forward edge of tread.

**OSHA 1910.24(c) "Stair strength."** Fixed stairways shall be designed and constructed to carry a load of five times the normal live load anticipated but never of less strength than to carry safely a moving concentrated load of 1,000 lb [454 kg].

**OSHA 1910.24(d) "Stair width."** Fixed stairways shall have a minimum width of 22 inches [559 mm].

**OSHA 1910.24(e) "Angle of stairway rise."** Fixed stairs shall be installed at angles to the horizontal of between 30 deg. and 50 deg. Any uniform combination of rise/tread dimensions may be used that will result in a stairway at an angle to the horizontal within the permissible range. Table D-1 gives rise/tread dimensions which will produce a stairway within the permissible range, stating the angle to the horizontal produced by each combination. However, the rise/tread combinations are not limited to those given in Table D-1.

Table D-1 Angle to horizontal [mm]	Rise (in inches) [mm]	Tread run (in inches) [mm]
30 deg. 35' [10668mm].....	6-1/2 [165mm].....	11 [279mm]
32 deg. 08' [2438mm].....	6-3/4 [171mm].....	10-3/4 [273mm]
33 deg. 41' [12497mm].....	7 [178mm].....	10-1/2 [267mm]
35 deg. 16' [4877mm].....	7-1/4 [184mm].....	10-1/4 [260mm]
36 deg. 52' [15850mm].....	7-1/2 [191mm].....	10 [254mm]
38 deg. 29' [8839mm].....	7-3/4 [197mm].....	9-3/4 [248mm]
40 deg. 08' [2438mm].....	8 [203mm].....	9-1/2 [241mm]
41 deg. 44' [13411mm].....	8-1/4 [210mm].....	9-1/4 [235mm]
43 deg. 22' [6706mm].....	8-1/2 [216mm].....	9 [229mm]
45 deg. 00' [0mm].....	8-3/4 [222mm].....	8-3/4 [222mm]
46 deg. 38' [11582mm].....	9 [229mm].....	8-1/2 [216mm]
48 deg. 16' [4877mm].....	9-1/4 [235mm].....	8-1/4 [210mm]
49 deg. 54' [16459mm].....	9-1/2 [241mm].....	8 [203mm]

**OSHA 1910.24(f) "Stair treads."** All treads shall be reasonably slip-resistant and the nosings shall be of non-slip finish. Welded bar grating treads without nosings are acceptable providing the leading edge can be readily identified by personnel descending the stairway and provided the tread is serrated or is of definite nonslip design. Rise height and tread width shall be uniform throughout any flight of stairs including any foundation structure used as one or more treads of the stairs.

**OSHA 1910.144(a)(3) Yellow.** Yellow shall be the basic color for designating caution and for marking physical hazards such as: Striking against, stumbling, falling, tripping, and "caught in between."

**OSHA 1926.451(f)(16)** Platforms shall not deflect more than 1/60 of the span when loaded.

**OSHA 1910.26(c)(3)(iii)** The ladder base section must be placed with a secure footing.

**OSHA 1910.26(c)(3)(iv)** The top of the ladder must be placed with the two rails supported, unless equipped with a single support attachment.

## OSHA 1910.27 Fixed ladders.

**OSHA 1910.27(a) Design requirements-(1) Design considerations.** All ladders, appurtenances, and fastenings shall be designed to meet the following load requirements:

**OSHA 1910.27(a)(1)(i)** The minimum design live load shall be a single concentrated load of 200 lb [91 kg].

**OSHA 1910.27(a)(1)(ii)** The number and position of additional concentrated live load units of 200 lb [91 kg] each as determined from anticipated usage of the ladder shall be considered in the design.

**OSHA 1910.27(a)(1)(iii)** The live loads imposed by persons occupying the ladder shall be considered to be concentrated at such points as will cause the maximum stress in the structural member being considered.

**OSHA 1910.27(a)(1)(iv)** The weight of the ladder and attached appurtenances together with the live load shall be considered in the design of rails and fastenings.

**OSHA 1910.27(b) Specific features-(1) Rungs and cleats.** (i) All rungs shall have a minimum diameter of three-fourths inch for metal ladders, except as covered in paragraph (b)(7)(i) of this section and a minimum diameter of 1 1/8 inches [29 mm] for wood ladders.

**OSHA 1910.27(b)(1)(ii)** The distance between rungs, cleats, and steps shall not exceed 12 inches [305 mm] and shall be uniform throughout the length of the ladder.

**OSHA 1910.27(b)(1)(iii)** The minimum clear length of rungs or cleats shall be 16 inches [406 mm]

**OSHA 1910.27(b)(2) Side rails.** Side rails which might be used as a climbing aid shall be of such cross sections as to afford adequate gripping surface without sharp edges, splinters, or burrs.

**OSHA 1910.27(b)(6) Welding.** All welding shall be in accordance with the "Code for Welding in Building Construction" (AWS D1.0-1966).

**OSHA 1910.27(c)(5) Clearance in back of grab bar.** ClearThe distance from the centerline of the grab bar to the nearest permanent object at the back of the grab bars shall be not less than 4 inches [102 mm]. Grab bars shall not protrude on the climbing side beyond the rungs of the ladder which they serve.

**OSHA 1910.27(d)(2)(iii)** One rung of any section of ladder shall be located at the level of the landing laterally served by the ladder. Where access to the landing is through the ladder, the same rung spacing as used on the ladder shall be used from the landing platform to the first rung below the landing.

**OSHA 1910.27(d)(3) Ladder extensions.** The side rails of through or side-step ladder extensions shall extend 3 1/2 feet [1067mm] above parapets and landings. For through ladder extensions, the rungs shall be omitted from the extension and shall have not less than 18 [457 mm] nor more than 24 inches [610 mm] clearance between rails. For side-step or offset fixed ladder sections, at landings, the side rails and rungs shall be carried to the next regular rung beyond or above the 3 1/2 feet [1067 mm] minimum. (fig. D-10).

**OSHA 1910.27(d)(4) Grab bars.** Grab bars shall be spaced by a continuation of the rung spacing when they are located in the horizontal position. Vertical grab bars shall have the same spacing as the ladder side rails. Grab-bar diameters shall be the equivalent of the round-rung diameters.

## TERMS AND CONDITIONS

- Without a written acceptance of these conditions by the Buyer, placement of an order for any of the goods covered by this quotation will constitute acceptance of these terms and conditions. The failure to object to provisions contained in a Buyer's order or other forms of communication will not be deemed a waiver of the terms and conditions.
- ErectaStep is not responsible for delays in satisfying this order caused by circumstances which are unavoidable or beyond our control.
- Typographical errors are subject to correction.
- All information supplied to the Buyer by ErectaStep may contain proprietary design information that belongs to and shall remain property of ErectaStep. They may not be copied without the expressed written consent of an officer of ErectaStep. All information must be returned immediately upon demand.
- ErectaStep sale of goods covered by this quotation does not grant the Buyer any license or right of any kind under any patent owned or controlled by ErectaStep or under which the company is licensee.
- 2 Year Limited Warranty – See below
- Returns: Returns must be in sellable condition and authorization in writing from our office and subject to a restocking fee. Unauthorized returns will be refused. The buyer is responsible for any freight charges.
- Liens: ErectaStep provides final lien waivers when payment is received in full.
- The field measurements utilized in formulating the prices for the equipment supplied by the Buyer or their representative. Any failure of the equipment to operate satisfactorily that is caused by incorrect data and/or field measurements being supplied to the Seller by the Buyer's personnel would be at the buyer's expense. This includes any changes in operating procedures, types of vehicle being serviced, or any changes to the physical surroundings which cause conditions to be outside the original field measurements that were taken. All costs associated with those changes would be at the Buyer's expense.

- Buyer assumes liability for patent and copyright infringement when goods are made to Buyer's specifications.
- If the Buyer cancels an order prior to its completion; the Buyer agrees to pay to Seller the percentage of the selling price based on the percentage of the completion, plus any costs for the disposal of used material. The Seller would determine the percentage of completion.
- Indemnity: Buyer shall indemnify and hold harmless ErectaStep, its affiliated companies, owners, employees, agents, and successors from and against any and all claims, expenses, liability, and loss arising from claims for injury, death, or damage to, or destruction of property arising from unauthorized repair or modifications to the products provided under this purchase order/quotation, as well as failure to properly maintain said products, improper use of said products, use of said products for anything other than their intended purpose, and/or the equipment not working or functioning property caused by a change in working parameters that were unknown by ErectaStep.

## WARRANTY

ErectaStep prides itself on it's workmanship and quality. We strive for perfection in each and every part that we manufacture. All ErectaStep parts are warranted for 2 years against defects. Abuse, extraordinary corrosion, improper installation and other things out of control of ErectaStep are not covered under warranty. Warranty is limited to repair or replacement parts shipped ground to destination as determined by ErectaStep. No additional costs incurred due to warranty related parts are covered i.e. labor, loss of use.

## INTENDED USE

All ErectaStep parts are pre-engineered with specific purpose for safe access and egress. It is very important to follow configuration guidelines as well as installation instructions provided with order. Design limitations can exist with respect to required supports, adequate footings and prescribed application. Applied loads beyond the stated design loads and use not as advertised are also not covered under the warranty. Any alteration in design or intended use or purpose beyond ErectaStep's recommendations or knowledge voids our warranty and liability against all claims. ErectaStep offers free design assistance to insure a safe, successful outcome to your project.



# RollAStep

MOBILE LADDERS AND PLATFORMS



**C Series**



**G Series**

- ✓ Access when you need it, where you need it.
- ✓ Designed with ease of use in mind.
- ✓ In stock and ready to ship!



**MP Series**



**TR Series**

***Designed for Work, Built for Safety.***

# C Series | Cantilever Rolling Platform

R-2

## Features fixed platform work area and single operator mobility.

The C Series's cantilever work platform allows an operator to take a position above and/or to move onto tall industrial machinery. The steel base provides exceptional counter balance, while the lightweight aluminum upper provides single user maneuverability.

A large, 6 sq.ft. (5.5742e+5 square mm) work platform provides ample room for an operator as well as parts and tools. The self-supporting platform extends 2'5" (737 mm) feet beyond the base of the chassis, providing access while eliminating contact with the equipment being serviced.



42" (1067 mm) high railing on platform and cage meet OSHA standards

Full-size 2" (51 mm) diameter handrails

Optional cage provides off-platform safety

Self-supporting platform



Each component is proudly crafted in our South Carolina facility.

Brittany  
Customer Service



Available in sizes from  
7 steps to 11 steps

See specs section for details



▲ All-weather slip-resistant tread



Optional cage provides off-platform safety

▲ The 24" (610 mm) wide by 36" (914 mm) long platform provides ample work area. Shown with optional YellowGate swing gate



▲ Wheels swivel 360° for easy placement

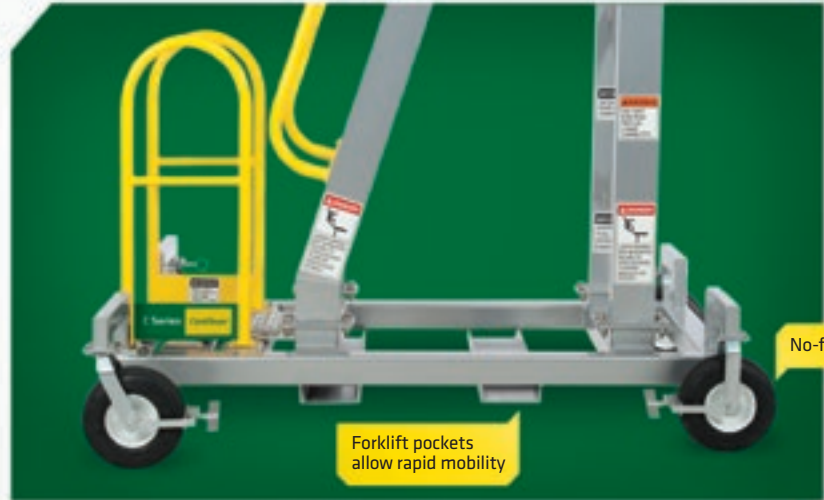

No-flat tires

Forklift pockets allow rapid mobility

▲ The heavy, galvanized steel base provides incredible stability, while large no-flat tires provide single user maneuverability

## Built for Safety.

The full size 2" (51 mm) diameter handrails are 42" (1067 mm) tall around the work platform and powder coated to meet OSHA standards.

Our aggressive, self-draining tread, is featured on both platforms and steps. This pattern provides safe, all weather access in both rain and snow and reduces ice build up.

## Easy to Roll.

The easy steer design and large no-flat tires allow a single operator to easily roll and position the unit, even over rough ground.

The 360° swiveling wheels provide perpendicular or parallel movement and allow easy positioning. Wheels lock for stability.

For efficient longer distance moves, forklift pockets allow rapid relocation.

# C Series | Cantilever Rolling Platform

R-4



The self supported cantilevered platform extends 2'5" (737 mm) beyond the wheel base. ▼

▲ The C Series is ideal for providing access to the tops of tank trucks.



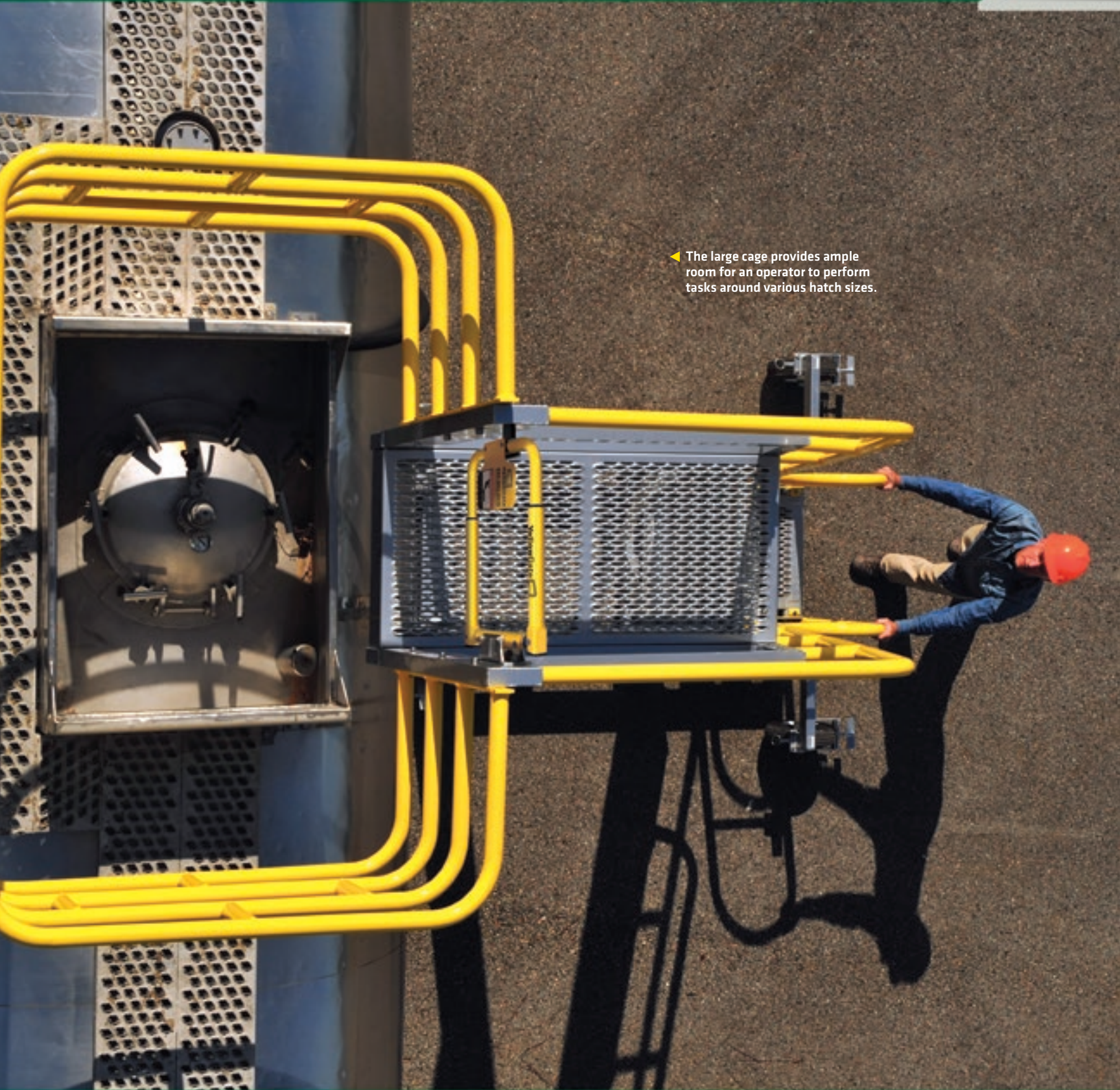

◀ The large cage provides ample room for an operator to perform tasks around various hatch sizes.

# G Series | Self-Leveling Stair & Work Platform

R-6

## Adjustable height anywhere you want it.

The G Series is a variable height, self-leveling platform. Its 24" (610 mm) wide steps and 6 sq.ft. (5.5742e+5 square mm) platform self-level to present a safe walk and work surface throughout its working range.

The aluminum upper, galvanized steel base and stainless hardware is built to last, both indoors and out.

**Includes Patent #7,950,095B2.**  
**Other patents pending.**



**Patsy**  
Customer Service



Self-supporting platform



Each component is proudly crafted in our South Carolina facility.





360° swivel casters allow for precise placement

▲ The wide steel base provides excellent stability.

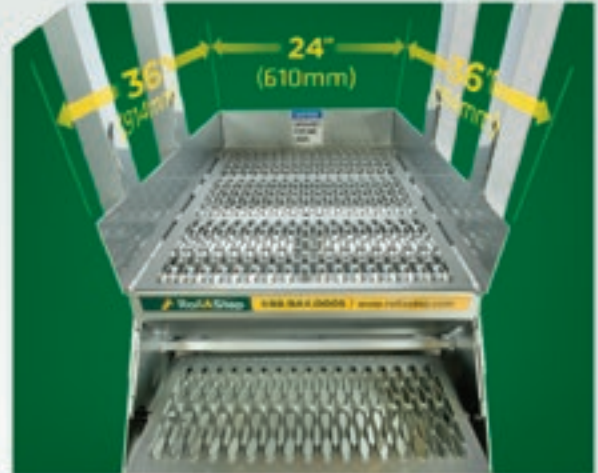

▲ Six sq.ft. (5.5742e+5 square mm) work area provides room for an operator and equipment.



Stairs and platform self-level at any height

Gas springs for easy height adjustment

## Adjustable Height.

The G Series adjusts height with the removal of a single locking pin.

The gas springs provide assistance in raising the platform, while gentle downward pressure lowers the platform.

Replace the locking pin at the desired height and the stair is ready for use.

# G Series | Self-Leveling Stair & Work Platform

R-8



Work at the correct height for the job. ▼

▲ Self-supporting platform protects fragile equipment.



- ▼ Work at multiple heights in multiple locations with a single platform.



# MP Series | Mobile Work Platform

R-10

The workspace of a fixed platform with the benefit of mobility.

## Built like a fixed platform.

The MP Series is a highly mobile work platform designed to bring the user to the level of the work with an unparalleled level of confidence and safety. The powder-coated handrails, full size 45° rise stair stringer, and standard width and depth steps meet OSHA specifications for mobile platforms. The lightweight aluminum construction and single user maneuverability ensure the MP will be a favorite and undoubtedly the 'Go-to' workhorse of any facility.



Each component is proudly crafted in our South Carolina facility.



Annette  
Customer Service

## Mobility

The MP Series is easily maneuvered by a single operator and the 360° swiveling casters allow precise positioning.

Locking casters prevent both swivel and roll, while the soft no-flat tires roll easily over asphalt and gravel.



Available in sizes from  
2 steps to 7 steps

See specs section for details



◀ D-Shaped rails for stronger surface to surface contact.



▲ Full sized stairs allow users to operate as if on a fixed platform.



## Configurability

Optional removable handrails give the MP series mobile platform unparalleled versatility.

Each handrail slides securely into and out of its retaining sleeve without tools, allowing operators to reconfigure the platform in the field.

# MP Series | Mobile Work Platform

R-12

Swiveling casters allow the MP to be easily positioned against machinery for inspection or service. ▶



◀ The 5 stair MP Series is the perfect tool for loading and unloading trucks.



▲ With all aluminum construction and powder coated handrails RollAStep is built to last – both indoors and out.

# MP Series | Mobile Work Platform

R-14



Allow operators the ease and safety of loading/securing safely before motoring. ▶



▲ RollAStep's individual removable handrails allow for quickly accessing specific locations along the platform without compromising safety in other areas.



# Flatbed Fall Protection

R-15



▲ One to two operators can safely move units away from trucks while entering and exiting the loading bays to prevent any damage.

# MP Series | Mobile Work Platform

R-16



## Customized to meet your needs.

Larger custom platforms allow for multiple users and equipment to be close at hand.

Cantilever platform and angled handrails ensure minimal gaps between platform and work area such as a fuselage of an aircraft. ▶



▲ Highly engineered custom cantilever rolling platform for the aeronautical industry



▲ Large rolling platform with single point hydraulic adjustability



▲ Large rolling platform easily maneuvered into place manually

# TR Series | Mobile Process Workstand

R-18

## Made for work. Designed for safety.

We designed our tilt and roll with room to get the job done, wherever it may be. The 6 sq.ft. (5.5742e+5 square mm) platform is large enough for an operator, tools and parts, with room to spare. The lightweight frame and unique side rolling wheels make this rolling platform highly mobile and easy to position in tight spaces.

300 lbs. (136 kg)  
Load Limit



Heather  
Receptionist



Each component is proudly crafted in our South Carolina facility.



▲ Full size, powder coated handrails.



▲ Six sq.ft. (5.5742e+5 square mm) of work area is roomy enough for an operator, tools and parts.



▲ The unique side rolling casters make the TR Series easy to position in tight areas.

## Built for safety.

The TR Series is anything but a standard stick-built rolling ladder.

- ▲ Full-size handrails
- ▲ Wide base and stairs
- ▲ Aggressive tread
- ▲ 42" (1067 mm) Handrail and midrail
- ▲ Full toeboard

The sturdy aluminum construction supports a 300lb (136 kg) load limit without sacrificing mobility.

# TR Series | Mobile Process Workstand

R-20



The wide base provides additional stability. ▼

▲ The additional platform area brings a new level of safety to warehousing tasks.



▼ The TR Series is designed with the stability and work area to get the job done.

# Specifications | C and G Series

R-22

The **C SERIES** is available in sizes ranging from 7 to 11 steps. Use the chart below to determine specifications for each size.

For more detailed drawings visit: [RollaStep.com](http://RollaStep.com)

C SERIES MODEL	A (ft) [mm]
C SERIES - 8	8' [2438]
C SERIES - 9	9' [2743]
C SERIES - 10	10' [3048]
C SERIES - 11	11' [3353]
C SERIES - 12	12' [3658]



C SERIES - 8 (8ft) (2438mm)



C SERIES - 9 (9ft) (2743mm)

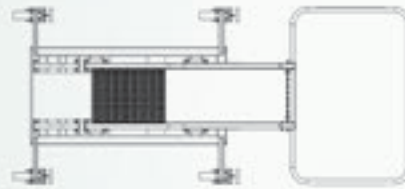
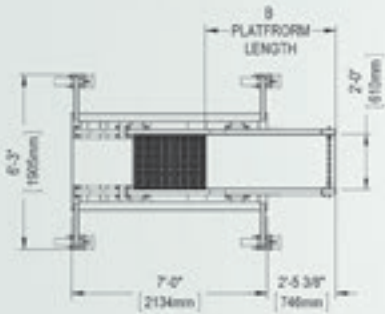

C SERIES - 10 (10ft) (3048mm)

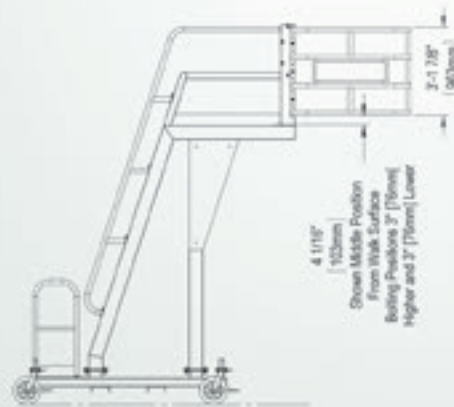
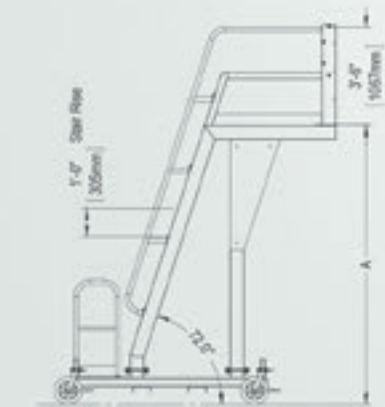

C SERIES - 11 (11ft) (3353mm)



C SERIES - 12 (12ft) (3658mm)



The **G SERIES** is available in sizes ranging from 7 to 10 steps. Use the adjacent chart to determine specifications for each size.

For more detailed drawings visit: [RollaStep.com](http://RollaStep.com)

G SERIES MODEL	A (inches) [mm]
G SERIES - 7	75.875" [1927]
G SERIES - 8	85.8125" [2180]
G SERIES - 9	95.75" [2432]
G SERIES - 10	105.75" [2686]

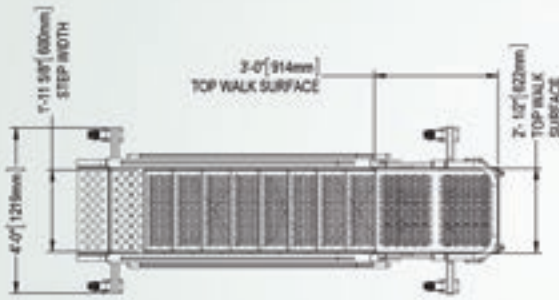

G SERIES - 7



G SERIES - 8

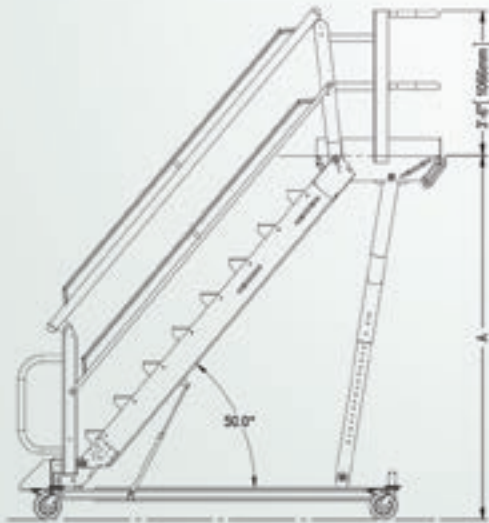

G SERIES - 10



G SERIES - 9



G SERIES - 10

# Specifications | MP and TR Series

R-24

The **MP SERIES** is available in sizes ranging from 2 to 7 steps. Use the adjacent chart to determine specifications for each size.

For more detailed drawings visit: [RollaStep.com](http://RollaStep.com)

MP SERIES MODEL	A (in) [mm]	B (in) [mm]
MP SERIES - 27	27" [686]	122.375" [3108]
MP SERIES - 36	36" [914]	131.375" [3337]
MP SERIES - 45	45" [1143]	140.375" [3566]
MP SERIES - 54	54" [1371]	149.375" [3794]
MP SERIES - 63	63" [1600]	158.375" [4023]
MP SERIES - 72	72" [1829]	167.375" [4251]

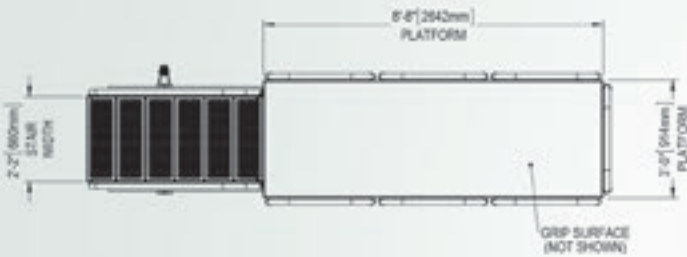

MP SERIES - MP-27



MP SERIES - MP-36



MP SERIES - MP-45



MP SERIES - MP-54



MP SERIES - MP-63



MP SERIES - MP-72

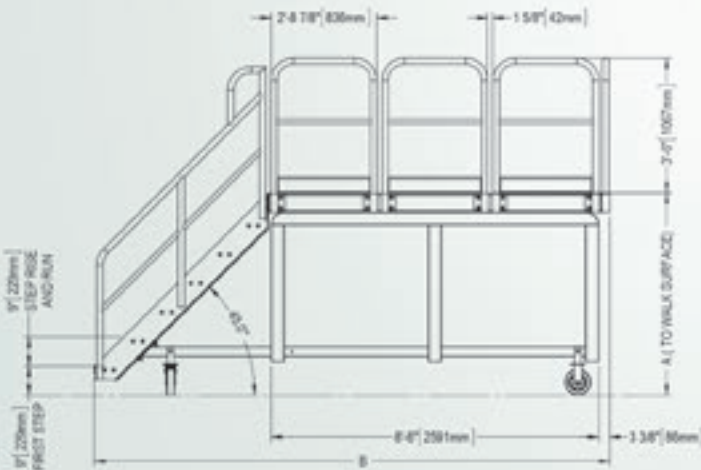

The **TR SERIES** is available in sizes ranging from 1 to 5 steps. Use the adjacent chart to determine specifications for each size.

For more detailed drawings visit: [RollaStep.com](http://RollaStep.com)

TR SERIES MODEL	A (in) [mm]	B (in) [mm]
TR SERIES - 24	24" [610]	66.0625" [1678]
TR SERIES - 36	36" [914]	70" [1778]
TR SERIES - 48	48" [1219]	72.9375" [1853]
TR SERIES - 60	60" [1524]	76.375" [1940]
TR SERIES - 72	72" [1829]	80.0625" [2034]

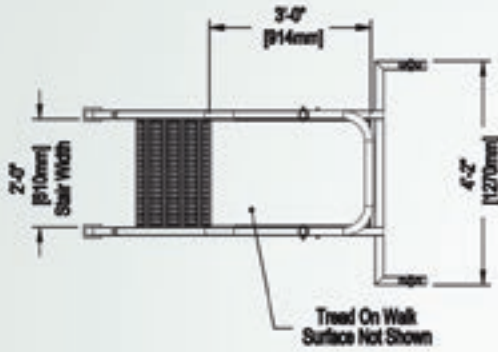

TR SERIES - 24

TR SERIES - 36

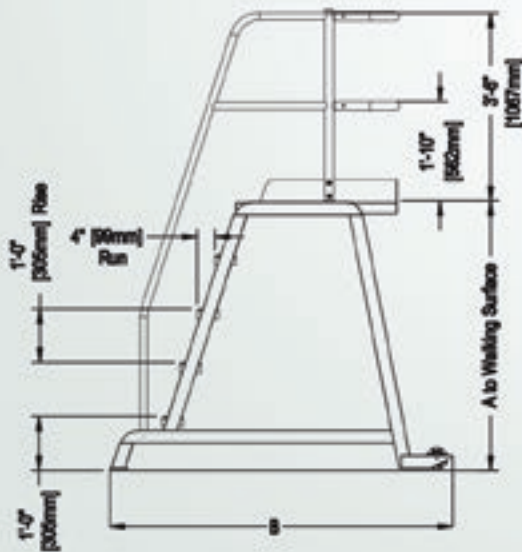

TR SERIES - 48



TR SERIES - 60



TR SERIES - 72

# OSHA Regulations

R-26

## United States of America Department of Labor Occupational Safety & Health Administration

### 1910.29(a)

"General requirements"-

#### 1910.29(a)(1)

"Application." This section is intended to prescribe rules and requirements for the design, construction, and use of mobile work platforms (including ladder stands but not including serial ladders) and rolling (mobile) scaffolds (towers). This standard is promulgated to aid in providing for the safety of life, limb, and property, by establishing minimum standards for structural design requirements and for the use of mobile work platforms and towers.

#### 1910.29(a)(2)

"Working loads."

#### 1910.29(a)(2)(i)

Work platforms and scaffolds shall be capable of carrying the design load under varying circumstances depending upon the conditions of use. Therefore, all parts and appurtenances necessary for their safe and efficient utilization must be integral parts of the design.

#### 1910.29(a)(2)(ii)

Specific design and construction requirements are not a part of this section because of the wide variety of materials and design possibilities. However, the design shall be such as to produce a mobile ladder stand or scaffold that will safely sustain the specified loads. The material selected shall be of sufficient strength to meet the test requirements and shall be protected against corrosion or deterioration.

#### 1910.29(a)(2)(ii)(a)

The design working load of ladder stands shall be calculated on the basis of one or more 200-pound (91kg) persons together with 50 pounds (23kg) of equipment each.

#### 1910.29(a)(2)(ii)(b)

The design load of all scaffolds shall be calculated on the basis of:

Light - Designed and constructed to carry a working load of 25 pounds per sq. ft. [11 kg].  
Medium - Designed and constructed to carry a working load of 50 pounds per sq. ft. [23 kg].  
Heavy - Designed and constructed to carry a working load of 75 pounds per sq. ft. [34 kg].  
All ladder stands and scaffolds shall be capable of supporting at least four times the design working load.

#### 1910.29(a)(2)(iii)

The materials used in mobile ladder stands and scaffolds shall be of standard manufacture and conform to standard specifications of strength, dimensions, and weights, and shall be selected to safely support the design working load.

#### 1910.29(a)(2)(iv)

Nails, bolts, or other fasteners used in the construction of ladders, scaffolds, and towers shall be of adequate size and in sufficient numbers at each connection to develop the designed strength of the unit. Nails shall be driven full length. (All nails should be immediately withdrawn from dismantled lumber.)

#### 1910.29(a)(2)(v)

All exposed surfaces shall be free from sharp edges, burrs or other safety hazards.

#### 1910.29(a)(3)

"Work levels."

#### 1910.29(a)(3)(i)

The maximum work level height shall not exceed four (4) times the minimum or least base dimensions of any mobile ladder stand or scaffold. Where the basic mobile unit does not meet this requirement, suitable outrigger frames shall be employed to achieve this least base dimension, or provisions shall be made to guy or brace the unit against tipping.

#### 1910.29(a)(3)(ii)

The maximum platform width for any work level shall not be less than 20 in [508 mm] for mobile scaffolds (towers). Ladder stands shall have a minimum step width of 16 in [406 mm].

#### 1910.29(a)(3)(iii)

The supporting structure for the work level shall be rigidly braced, using adequate cross bracing or diagonal bracing with rigid platforms at each work level.

#### 1910.29(a)(3)(iv)

The steps of ladder stands shall be fabricated from slip resistant treads.

#### 1910.29(a)(3)(v)

The work level platform of scaffolds (towers) shall be of wood, aluminum, or plywood planking, steel or expanded metal, for the full width of the scaffold, except for necessary openings. Work platforms shall be secured in place. All planking shall be 2-inch [51 mm] (nominal) scaffold grade minimum 1,500 f. [457 m] (stress grade) construction grade lumber or equivalent.

#### 1910.29(a)(3)(vi)

All scaffold work levels 10 feet [3048 mm] or higher above the ground or floor shall have a standard (4-inch [508 mm] nominal) toeboard.

#### 1910.29(a)(3)(vii)

All work levels 10 feet [3048 mm] or higher above the ground or floor shall have a guardrail of 2 [51 mm]- by 4-inch [102mm] nominal or the equivalent installed no less than 36 inches [914 mm] or more than 42 inches [1067 mm] high, with a mid-rail, when required, of 1 [25 mm] - by 4-inch [102 mm] nominal lumber or equivalent.

#### 1910.29(a)(3)(viii)

A climbing ladder or stairway shall be provided for proper access and egress, and shall be affixed or built into the scaffold and so located that its use will not have a tendency to tip the scaffold. A landing platform shall be provided at intervals not to exceed 30 feet [9144 mm].

#### 1910.29(a)(4)

"Wheels or casters."

#### 1910.29(a)(4)(i)

Wheels or casters shall be properly designed for strength and dimensions to support four (4) times the design working load.

#### 1910.29(a)(4)(ii)

All scaffold casters shall be provided with a positive wheel and/or swivel lock to prevent movement. Ladder stands shall have at least two (2) of the four (4) casters and shall be of the of the swivel type.

#### 1910.29(a)(4)(iii)

Where leveling of the elevated work platform is required, screw jacks or other suitable means for adjusting the height shall be provided in the base section of each mobile unit.

#### 1910.29(e)

"Mobile work platforms" -

#### 1910.29(e)(1)

"Design." Units shall be designed for the use intended and shall comply with the requirements of paragraph (a) of this section.

#### 1910.29(e)(2)

"Base width." The minimum width of the base of mobile work platforms shall not be less than 20 inches [508 mm].

#### 1910.29(e)(3)

"Bracing." Adequate rigid diagonal bracing to vertical members shall be provided.

# Order Form



QUANTITY	PART NO.	DESCRIPTION	WEIGHT	UNIT PRICE	SUBTOTAL
	11394	UNIVERSAL PLATFORM	46 lbs. (21kg)		
	11395	SAFETY HANDRAIL	21 lbs. (10kg)		
	11386	SAFETY STAIR UNIT 1 (1 step)	44 lbs. (20kg)		
	11387	SAFETY STAIR UNIT 2 (2 step)	64 lbs. (29kg)		
	11388	SAFETY STAIR UNIT 3 (3 step)	88 lbs. (40kg)		
	11389	SAFETY STAIR UNIT 4 (4 step)	108 lbs. (49kg)		
	11390	SAFETY STAIR UNIT 5 (5 step)	130 lbs. (59kg)		
	11391	SAFETY STAIR UNIT 6 (6 step)	150 lbs. (68kg)		
	11392	SAFETY STAIR UNIT 7 (7 step)	170 lbs. (77kg)		
	11393	SAFETY STAIR UNIT 8 (8 step)	190 lbs. (86kg)		
	11465	SAFETY STAIR UNIT 9 (9 step)	210 lbs. (95kg)		
	11466	SAFETY STAIR UNIT 10 (10 step)	230 lbs. (104kg)		
	11467	SAFETY STAIR UNIT 11 (11 step)	250 lbs. (113kg)		
	11378	TOWER SUPPORT 1	13 lbs. (6kg)		
	11379	TOWER SUPPORT 2	18 lbs. (8kg)		
	11380	TOWER SUPPORT 3	23 lbs. (10kg)		
	11381	TOWER SUPPORT 4	28 lbs. (13kg)		
	11382	TOWER SUPPORT 5	34 lbs. (15kg)		
	11383	TOWER SUPPORT 6	45 lbs. (20kg)		
	11384	TOWER SUPPORT 7	50 lbs. (23 kg)		
	11385	TOWER SUPPORT 8	55 lbs. (25kg)		
	11468	TOWER SUPPORT 9	60 lbs. (27kg)		
	11469	TOWER SUPPORT 10	65 lbs. (29kg)		
	11470	TOWER SUPPORT 11	70 lbs. (32kg)		
	11457	LADDER UNIT 1 (2 rungs)	44 lbs. (20kg)		
	11458	LADDER UNIT 2 (3 rungs)	50 lbs. (23 kg)		
	11459	LADDER UNIT 3 (4 rungs)	55 lbs. (25kg)		
	11460	LADDER UNIT 4 (5 rungs)	60 lbs. (27kg)		
	11461	LADDER UNIT 5 (6 rungs)	66 lbs. (30kg)		
	11462	LADDER UNIT 6 (7 rungs)	71 lbs. (32kg)		
	11463	LADDER UNIT 7 (8 rungs)	77 lbs. (35kg)		
	11464	LADDER UNIT 8 (9 rungs)	82 lbs. (37kg)		
	11488	LADDER UNIT 9 (10 rungs)	87 lbs. (39kg)		
	11489	LADDER UNIT 10 (11 rungs)	93 lbs. (42kg)		
	11490	LADDER UNIT 11 (12 rungs)	98 lbs. (44kg)		

► GRAND TOTAL



QUANTITY	PART NO.	DESCRIPTION	UNIT PRICE	SUBTOTAL
	11781	RS-CANTILEVER SERIES-C8		
	11782	RS-CANTILEVER SERIES-C9		
	11783	RS-CANTILEVER SERIES-C10		
	11784	RS-CANTILEVER SERIES-C11		
	11785	RS-CANTILEVER SERIES-C12		
	11786	RS-MP SERIES-MP27		
	11787	RS-MP SERIES-MP36		
	11788	RS-MP SERIES-MP45		
	11789	RS-MP SERIES-MP54		
	11790	RS-MP SERIES-MP63		
	11791	RS-MP SERIES-MP72		
	11793	RS-G SERIES-G7		
	11794	RS-G SERIES-G8		
	11795	RS-G SERIES-G9		
	11796	RS-G SERIES-G10		
	11797	RS-TR SERIES-TR24		
	11798	RS-TR SERIES-TR36		
	11799	RS-TR SERIES-TR48		
	11800	RS-TR SERIES-TR60		
	11801	RS-TR SERIES-TR72		

► GRAND TOTAL



QUANTITY	PART NO.	DESCRIPTION	UNIT PRICE	SUBTOTAL
	11792	RS-YELLOWGATE-A		

► GRAND TOTAL

# YellowGate Fall Protection

Y-1



## One Gate. Fits All. Stops Falls. Simplify compliance with one gate.

YellowGate's twenty inches (508 mm) of adjustability, field-reversible swing direction and universal mounting system protects every passageway, with just one fall protection product.

Simply count the number of openings where fall protection is required and place your order – no time consuming tracking of measurements or mounting types required and no costly returns due to ordering the wrong size or swing.

Each gate is field adjustable for both length and swing direction with a single wrench. The universal mounting system mounts to walls, angle iron and round pipe or square tube with no additional parts to order.



Each component is proudly crafted in our South Carolina facility.



▲ Parallel mount



▲ Field-adjustable length from 16" [406 mm] to 36" [914 mm].



▲ Perpendicular mount



▲ 24" [610 mm] wide platform.



▲ Universal mounting systems mounts with no additional parts to order.

## Universal Mount

The universal mount's parallel and perpendicular mounting capabilities meet any installation requirement, no additional parts required.

# YellowGate Fall Protection

Y-3

## Patent Pending Malbec Tensioner

No spring to fail.

The Malbec Tensioner eliminates the need for a swing gate's most common failure point, the spring. The patent pending system provides field adjustable tension and maintenance free closure, every time.

YellowGate can swing either in or out by simply relocating two bolts.

### Universal Mount

Mounts anywhere, no additional parts required.

Mounts to walls, round and square tube and angle iron, with a single mount.

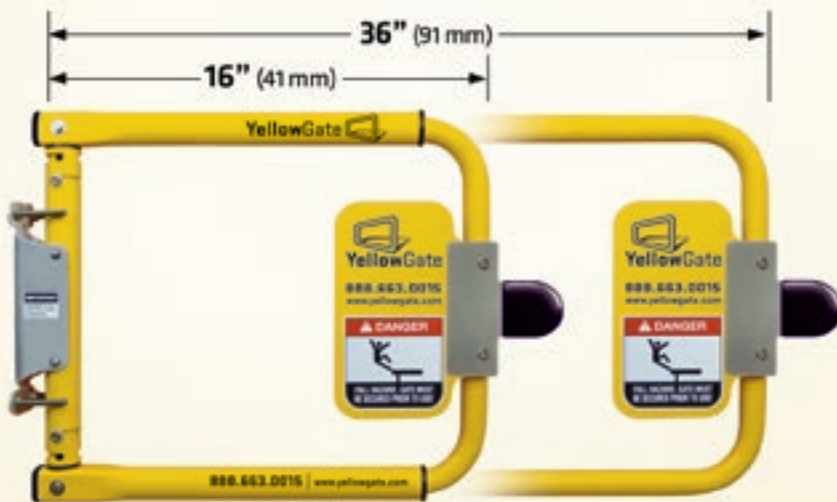
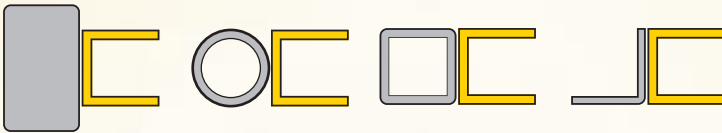

### OSHA Regulation

#### 1910.23 Guarding Floor & Wall Openings & Holes

(a) Protection of floor openings

(a.2) Guard ladderway floor openings or platforms like a stairway floor opening with passage through the railing either provided with a swinging gate or offset so a person cannot walk directly into the opening.

## The Most Adjustable Swing Gate Available.

Easily adjusts from 16" [406 mm]  
wide to 36" [914 mm]

Minimum width of YellowGate unit: 16" [406 mm] in perpendicular configuration, 19.5" [495 mm] in parallel configuration.



Each component is proudly crafted in our South Carolina facility.



# YellowGate XL

## The Most Adjustable Barrier Gate Available

### PRODUCT KEY FEATURES

- Field adjustable patent pending Malbec Tensioner
- Adjustable from 6' [1829 mm] - 12' [3658 mm], with a 42" [1067 mm] height
- Powder coated safety yellow
- Aluminum extruded, laser precision manufactured
- Maintenance free ergonomic design
- OSHA Compliant



### Field Adjustable

The same patent pending Malbec Tensioner system found in the YellowGate. Providing a perfect fit to any barrier gate project.

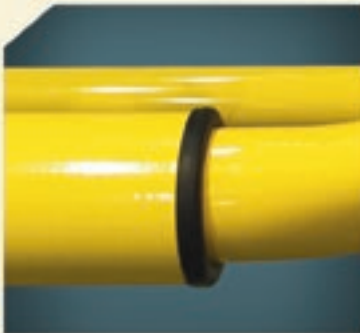

▲ Field-adjustable length from 6' [1829 mm] to 12' [3658 mm]

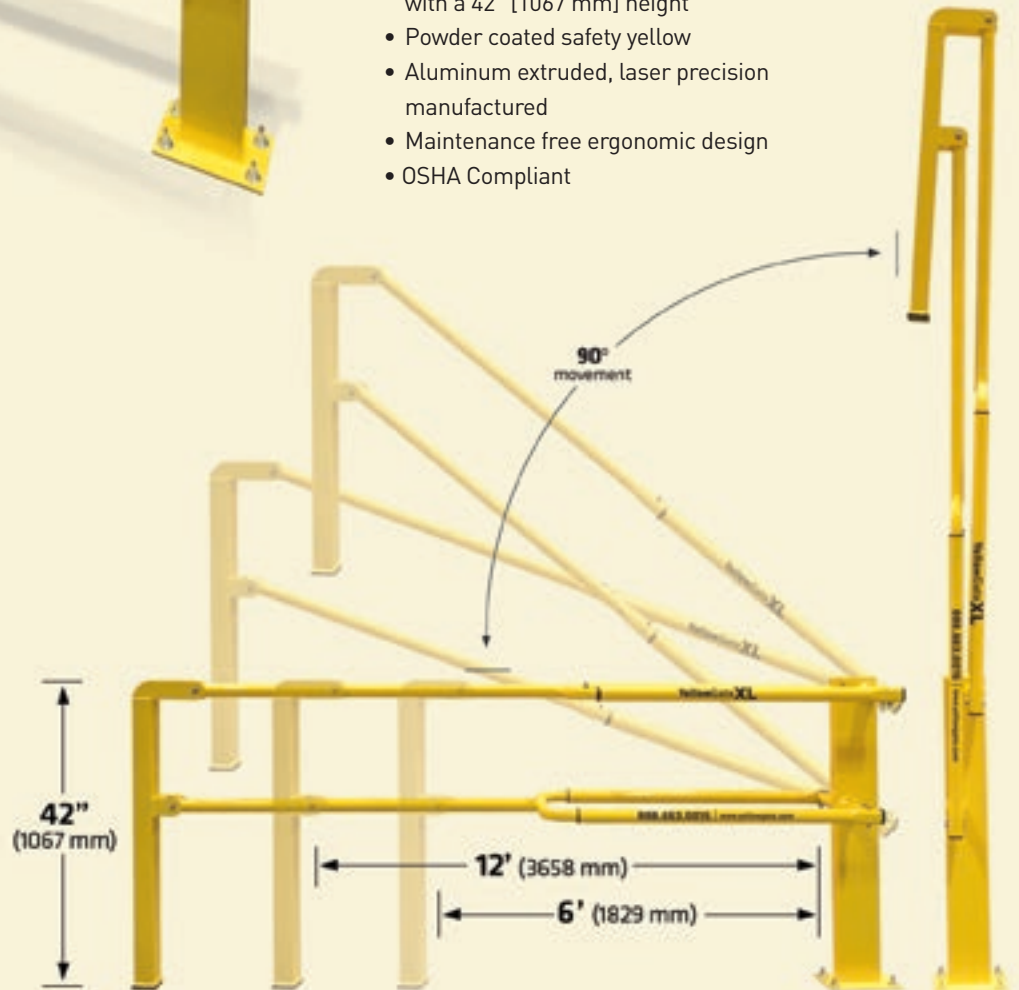

▲ Easily adjusts in the field from 6' [1829 mm] to 12' [3658 mm]



## About Us

We are committed to safety, quality and customer service in both our product designs and our manufacturing ideology. Our advanced technology allows us to respond faster, reduce lead times and lower costs – without compromising quality and engineered design.

**E** ERECT A STEP

**RollA**Step

**YellowGate**

**PERFECT A STEP**



Our state-of-the-art facility  
in Andrews, South Carolina



**Call us today...  
There's a better way.**





SixAxis LLC // 219 Safety Avenue // Andrews // SC // 29510

Kent Innovation Centre // Thanet Reach Business Park // Millennium Way  
Broadstairs // Kent // CT10 2QQ // ENGLAND

© 2015 SixAxis LLC