



Ground Verification Clamp and Cable Unit

For use with Sculcon Junction Box, Model SC-47CC/CLMP

Featuring Dynacheck® – Automatic and Continuous Self-Checking Circuitry



Model SC-47CC/CLMP

DESCRIPTION

The Scully SC-47CC/CLMP Clamp and Cable Unit is designed to drain static charges built up on vehicles, railcars and other metal liquid tank containers. The clamp unit is designed to be connected, via two wires, to the Scully Groundhog™ grounding verification system. When the clamp is attached to bare metal on the tank container, the system utilizes an intrinsically safe signal to verify that a proper static bond exists during liquid transfer operations.*

Static grounding is used to dissipate any static charges which can build up as a result of product flow or other movement. Some applications such as rail lines and pipelines may also have stray currents present. In these situations the rail or pipeline must be bonded to ground independently from the Scully system. Local codes should be consulted regarding wire gauges and number of conductors.

If the clamp is not properly attached to the tank vehicle, the system will not allow product to transfer. If at any time during the transfer process the clamp is disconnected, the system will send a signal to stop the product transfer.

The clamp and cable unit is connected to a heavy duty, weatherproof junction box. The junction box acts as a housing to connect the cable wires and the controller wiring. In the event of a drive-away, the cable pulls out of the junction box. This maintains vapor tight safety and prevents damage at the control monitor. Other systems without a junction box disconnect and may allow non-intrinsically safe signals within the liquid transfer environment during a drive-away accident.

FEATURES AND BENEFITS

- Verification of static grounding when properly connected to the trailer frame.
- Heavy-duty, weather-sealed aluminum junction box to house cable wiring.
- Intrinsically safe operation.
- The clamp and cable disconnects from the junction box during a drive-away accident, preventing damage to the control monitor and maintaining intrinsic safety.
- Spring-loaded clamp jaws with adjustable contact pins for a solid bond to the trailer frame.

*WARNING

When used in conjunction with a Scully Groundhog, the clamp provides a resistance (non self-proving) verification system. Thus, attaching the clamp to a metallic object or to a vehicle, which already has a return path to ground,

could give a permissive indication through this alternate path, which may not include the vehicle. To ensure self proving operation, the vehicle must be equipped with a Groundbolt or Groundball.



67206 Rev D

For use with Sculcon Junction Box, Model SC-47CC/CLMP

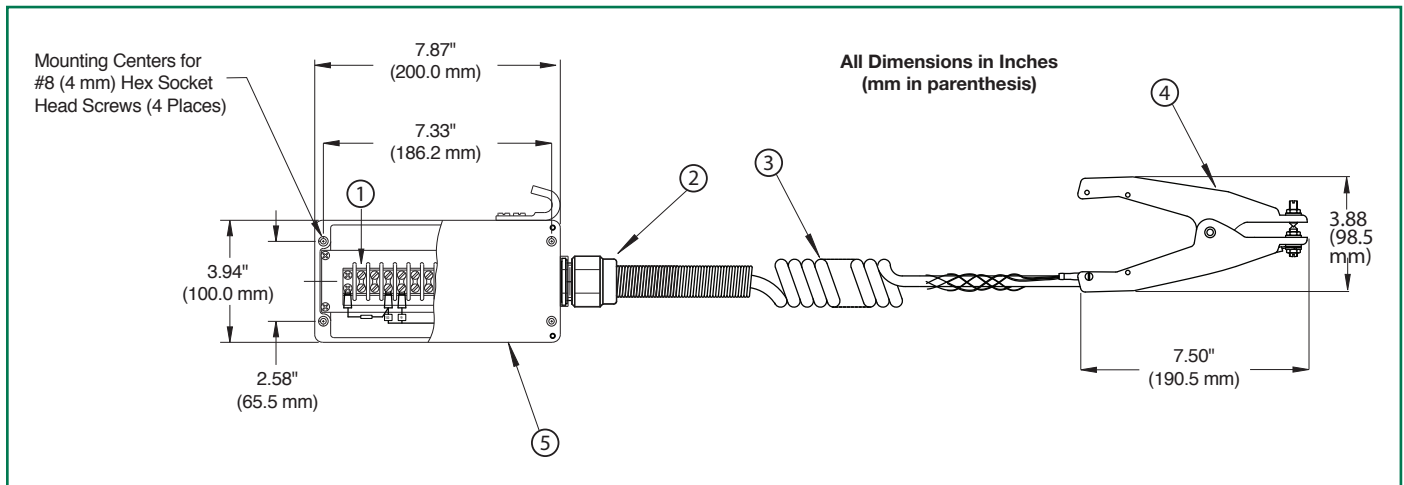

TECHNICAL SPECIFICATIONS

Junction Box: Weather-sealed die-cast aluminum box. Stainless steel external hardware.

Clamp: Aluminum alloy, corrosion resistant. Stainless steel contact points.

Cable: Oil resistant, Philaprene 2-Jacketed
Coiled: 32' (extended) (10 meter)
Straight: 20' (6 meter)

Cable Strain Relief: Stainless Steel

Clamp Strain Relief: Stainless Steel

ORDERING INFORMATION

Description	Part Number
SC-47CC/CLMP Clamp and 32' Coiled Cable	08815
SC-47/CLMP Sculcon Junction Box, Clamp and 20' Straight Cable	09333

REPLACEMENT PARTS

Terminal Strip, 12-position	27647
Strain Relief, 3/8" – for Grounding Cable	32445
Clamp and Cable Assembly, 32' Coiled Cable	31766
Clamp and Cable Assembly, 20' Straight Cable	32665
Replacement Clamp	31778
Sculcon Box Assy, General Purpose	32319

Copyright © 2013 Scully Signal Company. Dynacheck, Dynamic Self-Checking, Dynamic Self-Testing, Faylsafe, IntelliCheck, Intellitrol, Load-Anywhere are registered trademarks of Scully Signal Company. All Rights Reserved.
Specifications are subject to change without notice.

67206 Rev D
December 2013



Scully Signal Company
70 Industrial Way
Wilmington, MA 01887, USA
800 272 8559 • sales@scully.com

Scully Systems Europe NV
Maanstraat 25
2800 Mechelen, Belgium
+32 (0) 15 56 00 70 • info@scully.be

Scully UK Ltd
Meridian House, Unit 33
37 Road One Winsford Industrial Estate,
Winsford Cheshire CW7 3QG, UK
+44 (0) 1606 553805 • sales@scullyuk.com

