



Honeywell Versatilis™ Signal Scout™
Release 100

Installation and User's Guide

34-VT-25-02
February 2023

DISCLAIMER

This document contains Honeywell proprietary information. Information contained herein is to be used solely for the purpose submitted, and no part of this document or its contents shall be reproduced, published, or disclosed to a third party without the express permission of Honeywell International Sàrl.

While this information is presented in good faith and believed to be accurate, Honeywell disclaims the implied warranties of merchantability and fitness for a purpose and makes no express warranties except as may be stated in its written agreement with and for its customer.

In no event is Honeywell liable to anyone for any direct, special, or consequential damages. The information and specifications in this document are subject to change without notice.

Copyright 2023 - Honeywell International Sàrl.

CONTENTS

Chapter 1 - About this guide	5
Revision history	5
Related documents	5
Terms and abbreviations	5
Chapter 2 - Instructions and safety measures	7
Precautions	7
Hazardous locations	7
Best practices	8
Chapter 3 - Honeywell Versatilis Signal Scout Overview	10
Key features	10
Illustrations and dimensions	12
Chapter 4 - Specifications	14
Chapter 5 - Setting up the Honeywell Versatilis Signal Scout	17
Unpacking the Contents	17
Mounting Honeywell Versatilis Signal Scout	20
Pre-installation Considerations	20
Magnetic Mounting	21
Adhesive Mounting	22
Screw Mounting	23
Chapter 6 - Configuration	25
Installation of Honeywell Versatilis Connect App	27
Prerequisites:	27
Resetting Passcode for the Honeywell Versatilis Connect app	28
Configure LoRa Gateway	30
Configure LoRaWAN	31

LoRa Network (LoRaWAN) Setup	31
Honeywell Emissions Management Solution	35
Chapter 7 - Security	36
Security features	36
Physical security	36
Chapter 8 - Maintenance	37
Replacement of Honeywell Versatilis Signal Scout	38
Firmware update	38
System logs	38
Chapter 9 - LED States	39
Chapter 10 - Troubleshooting	43
Chapter 11 - Certifications	46
Notices	54

ABOUT THIS GUIDE

This guide provides information to assist you in installation, configuration, maintenance, and troubleshooting scenarios of the Honeywell Versatilis Signal Scout.

Revision history

Revision	Date	Description
A	February 2023	The initial release of the document for R100.

Related documents

Document Name	Document Number
Honeywell Versatilis Connect App User's Guide	34-VT-25-03
Honeywell Versatilis Signal Scout Technical Specification	34-VT-03-02

Terms and abbreviations

Terms	Definitions
ATEX	Appareils destinés à être utilisés en Atmosphères Explosives
BLE	Bluetooth® Low Energy
CCOE	Chief Controller of Explosives
CAPEX	Capital Expenditures
iOS	iPhone Operating System

Terms	Definitions
IIoT	Industrial Internet of Things
LoRa	"Long Range" Radio Communication Technique
LPWA	"Low Power, Wide Area" networking protocol
MPS	Molecular Property Spectrometer
OPEX	Operational Expenditure
OTAA	Over The Air Activation

INSTRUCTIONS AND SAFETY MEASURES

Precautions

The following precautions must be exercised to use the Honeywell Versatilis Signal Scout safely and effectively:

- Honeywell will not provide any guarantee, if the Signal Scout is disassembled.
- The battery may present a potential electrostatic ignition hazard when dissembled.
- Improper use may lead to battery fluid leakage, excessive heat, ignition, or explosion.
- Honeywell will not be liable for any hazard that might be caused due to negligence in handling the Signal Scout.
- Care should be taken to protect this Signal Scout from impact or abrasion if located in a Zone 0/Class I Div 1 environment.
- It is the responsibility of the end user to verify that the Signal Scout has the necessary approvals required for the intended area of use.
- Ensure that the operating environment of the Signal Scout is consistent with the appropriate hazardous location's certification.

Hazardous locations

Honeywell Versatilis Signal Scout is available with IECEx, ATEX, UKCA Ex, North America Class I Div I and CCoE approvals.

For more information, see [certifications](#) section.

Best practices

Table 2-1: Best Practices - DOs











DOs	
	Ensure there is an adequate space to access the Signal Scout before selecting an installation position.
	The Signal Scout must be installed vertically perpendicular to the target structure (like beams, pipes, frames, etc) for overall best performance.
	Ensure the target surface of the structure is free from greasy, corrosion, abrasion, and uneven surfaces. So, the magnetic adapter attaches firmly to the target surface, thereby improving the measurement of frequency response.
	Ensure there are no damages, pigments, dents, or Contortion to the surface of the Signal Scout's base. Any such deformations or pigments may affect performance and measurement accuracy.
	Ensure that there is no visible damage to the filter on the face of the sensor, before installation. If the filter is damaged then the sensor will not function as intended.
	Dispose the Signal Scout and battery according to laws and regulations.
	Installation in an explosive environment must be under the appropriate local, national, and international standards, codes, and practices.

Table 2-2: Best Practices - DON'Ts

DON'Ts	
	<p>Do not remove the Signal Scout's enclosure without written consent from Honeywell. The Signal Scout is packaged with battery and sensitive electronics, that may be damaged without proper care. Pay attention to don'ts when the Signal Scout's enclosure is removed:</p> <ul style="list-style-type: none">• Do not short-circuit.• Do not disassemble or change.• Do not expose to heat or fire.
	<p>Do not use bare hands while installing the magnetic adapter on the target structure as the magnet is powerful and can pinch the skin/ fingers if not handled properly.</p>
	<p>Do not mount the adhesive mount adapter on uneven, rough, or curved surfaces as there is a potential risk of falling down of the Signal Scout due to the lack of sufficient bonding area.</p>

HONEYWELL VERSATILIS SIGNAL SCOUT OVERVIEW

Honeywell Versatilis Signal Scout is a smart methane gas leak detector that uses Molecular Property Spectrometer (MPS) technology and a patented design to deliver rapid and accurate methane gas leak detection across a variety of industries from the oil and gas supply chain to safety applications.

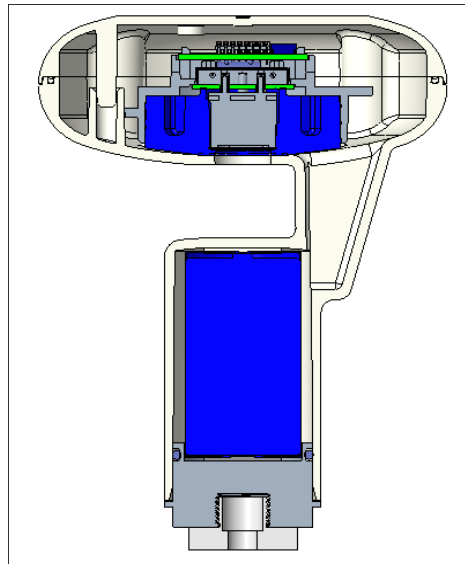









Figure 3-1: Honeywell Versatilis Signal Scout Cross-section View

Key features

The key features of the Honeywell Versatilis Signal Scout are as follows:

Table 3-1: Key Features of Honeywell Versatilis Signal Scout

	<p>Based on the latest LoRaWAN[®] protocol communication technology for large area coverage.</p>
	<p>Compact and patented* aerodynamically optimized design.</p>

	Built-in battery compartment, battery lasts for 18 months to 2 years.
	Quick and easy installation and commissioning (no cabling).
	Poison resistant, robust, and intrinsically safe. Built-in environmental compensation and self-testing for fail-safe operation.
	Access real time and historical data, with insights visualization supported.
	Configurable sensor parameters, and data update frequency rate.
	Multiple mounting options available.
* Patent is applied, yet to be granted.	

Illustrations and dimensions

The physical dimensions of the Honeywell Versatilis Signal Scout are shown below:

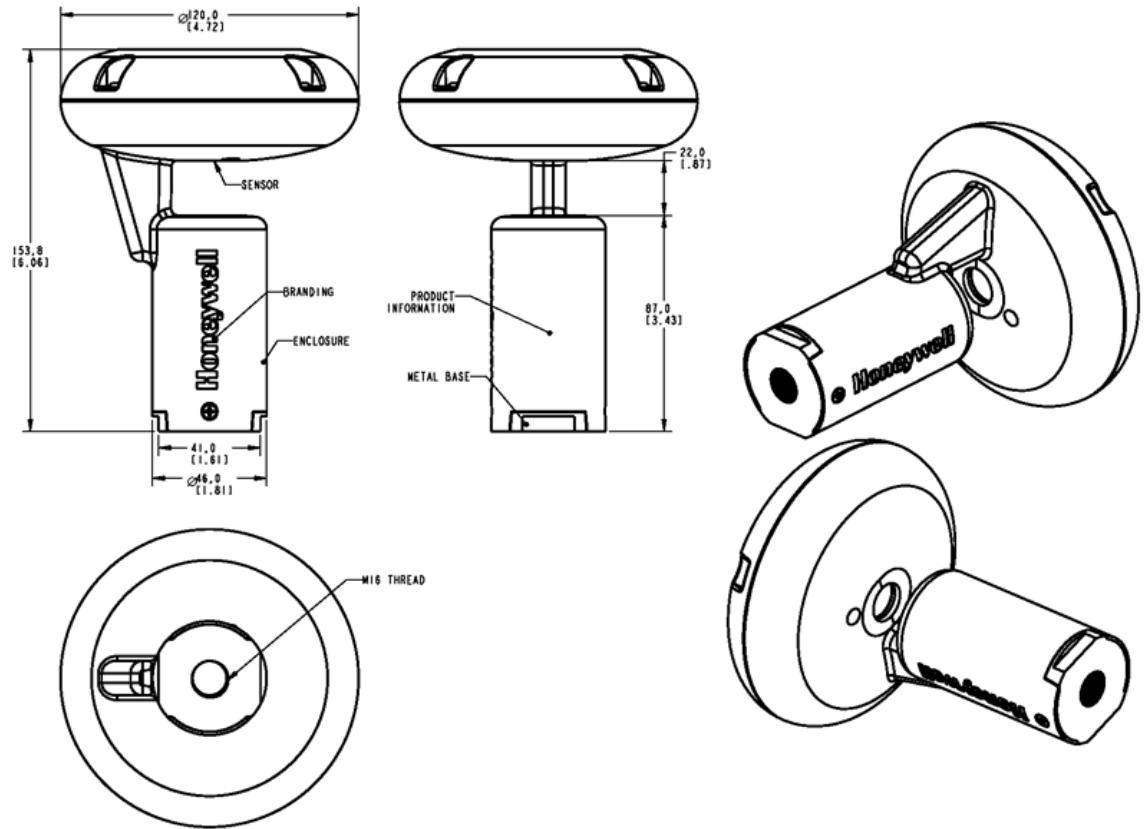

Figure 3-2: Dimensions of Signal Scout without adapter

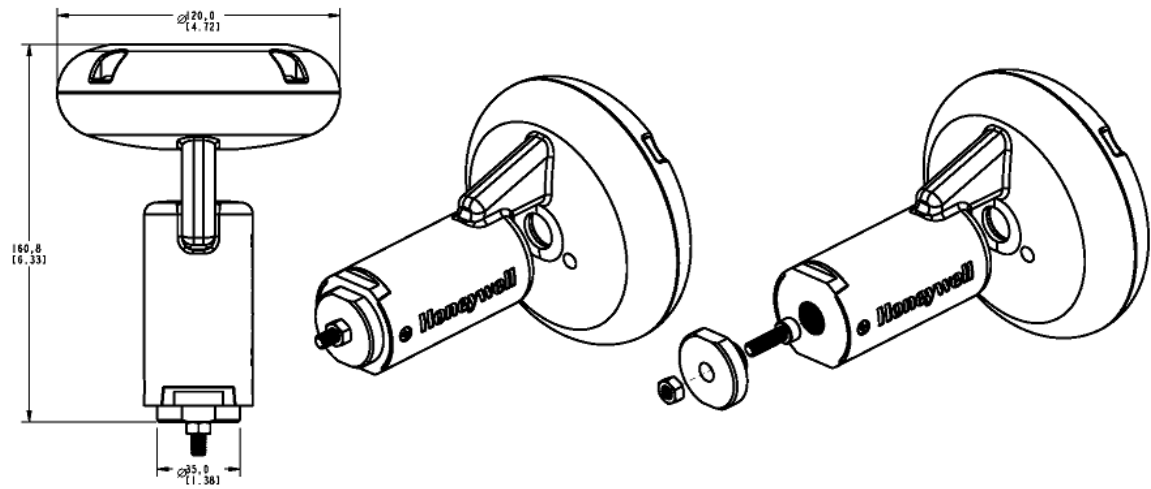

Figure 3-3: Dimensions of Signal Scout with Screw mount adapter

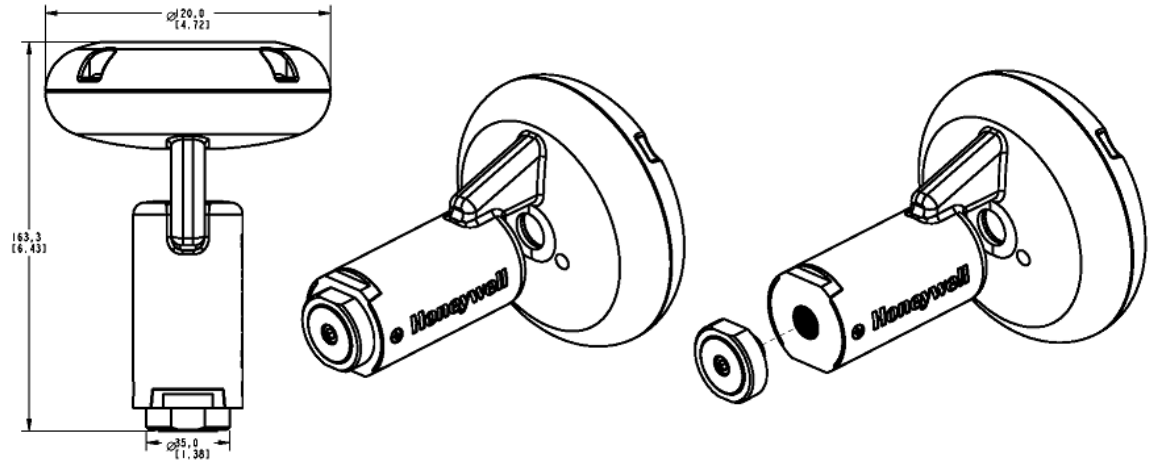

Figure 3-4: Dimensions of Signal Scout with Magnetic mount adapter

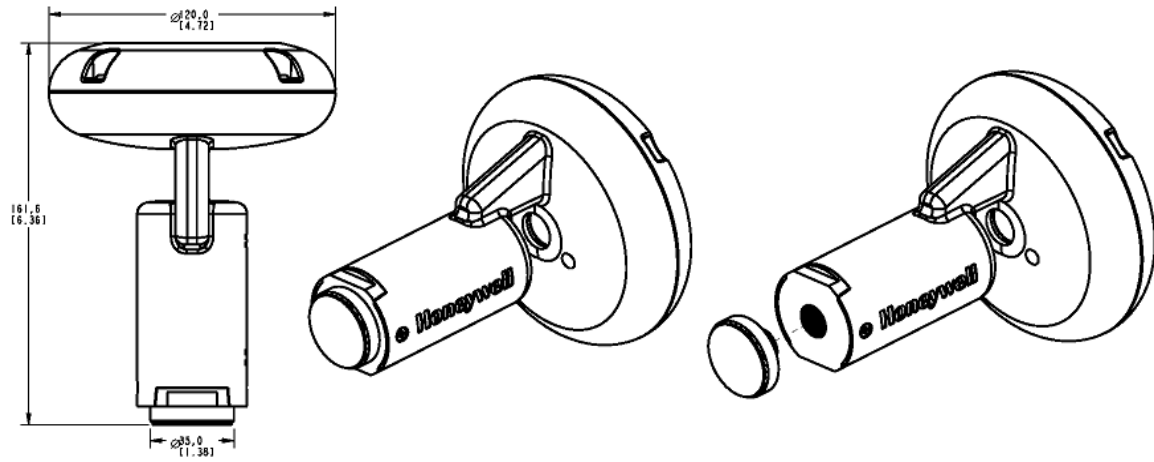

Figure 3-5: Dimensions of Signal Scout with Adhesive mount adapter

SPECIFICATIONS

Hardware Specifications

The following table provides the hardware specifications of Honeywell Versatilis Signal Scout:

Table 4-1: Hardware Specifications of Honeywell Versatilis Signal Scout

Parameters	Description
LoRaWAN® Class-A	863 to 928 MHz, Long Range Communication (LoRaWAN®) Class-A for supporting all the regions.
LoRaWAN® Data Publish	Real time Sensor parameters sent to the cloud for analytics: Methane gas concentration, Pressure, Humidity, Temperature.
BLE Communication	2.4 GHz, Bluetooth® Low Energy 5.0 Communication for Configuration.
Battery	The Low power detector (Signal Scout) is energized by Primary Battery; Li/SOCl ₂
Battery life	18 months ¹
Battery voltage	3.6 VDC
Signal Scout status indication	For LED status indication, see LED States .
Gas Sensor	Molecular Property Spectrometer (MPS) methane sensor: 50ppm to 1,000,000ppm concentration.
Pressure Sensor	300 to 1100 hPa
Humidity Sensor	0 to 100 %RH

Parameters	Description
Temperature Sensor	-40°C to 85°C (-40 to +185°F)
Physical dimensions (without adapter)	H 153.8mm (6.06 Inches) x D 120mm (4.72 Inches)
Weight	500gm
Mounting adapters	Magnetic, Screw, and Adhesive mount adapters. For more information, see "Mounting Honeywell Versatilis Signal Scout " on page 20.
¹ Battery Life of 18 months @6sec Sampling Rate, during ON period of 5 mins, at every 20 mins (configurable).	

For more information, see *Honeywell Versatilis Signal Scout Technical Specification*.

Environmental Conditions

The following table provides the operating conditions of Honeywell Versatilis Signal Scout:

Table 4-2: Environmental Conditions of Honeywell Versatilis Signal Scout

Information	Value
Ambient temperature range	-40°C to +70°C (-40°F to +158°F)
Humidity range	0 to 100 %RH
Usage	Indoor and Outdoor*
*NEMA Type 4X rating approval is in progress. This will enable Outdoor installations for North America region.	

Product Label

The following figure shows the product label of Honeywell Versatilis Signal Scout for your reference. The label will be printed on the enclosure of the Signal Scout.

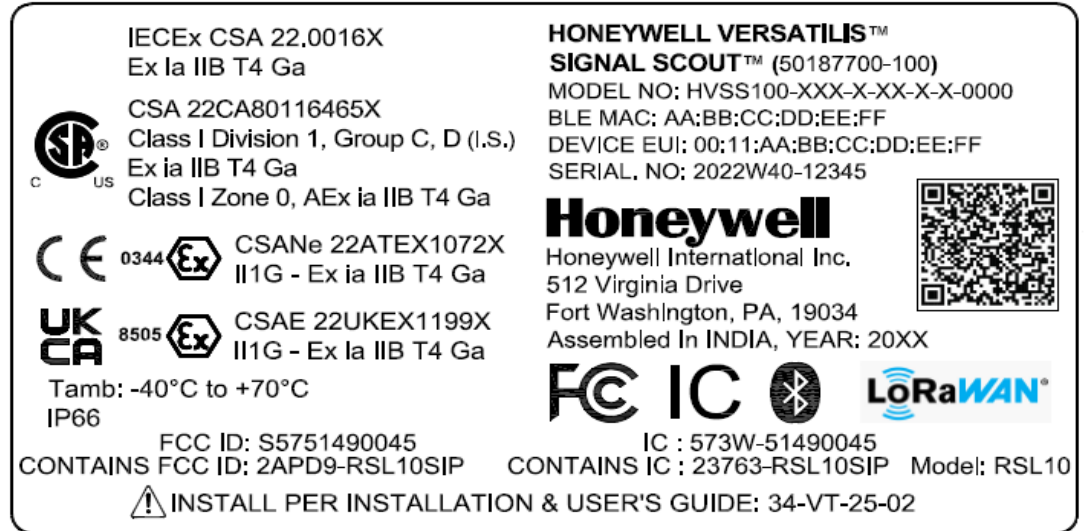

Figure 4-1: Product Label of Honeywell Versatilis Signal Scout

SETTING UP THE HONEYWELL VERSATILIS SIGNAL SCOUT

Unpacking the Contents

Honeywell Versatilis Signal Scout comes in a molded pulp packaging of sustainable recyclable material, sealed with a tamper proof sticker. These multiple units of molded pulp packages (including Signal Scouts inside) are packed into the grids provided in the cardboard container for shipping.

Refer the instructions as shown in the below figure to unpack the Honeywell Versatilis Signal Scout from the shipping container:

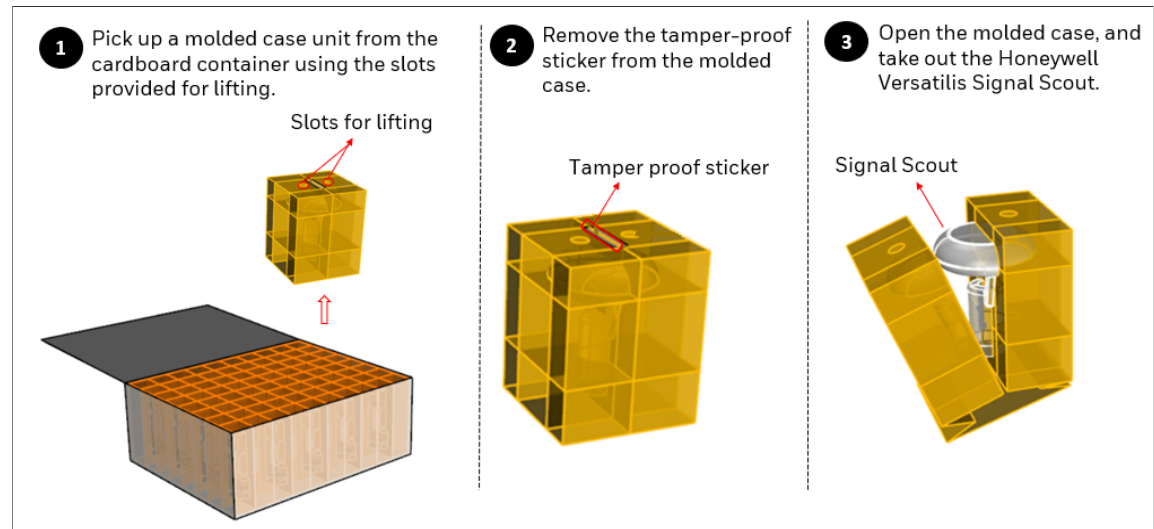

Figure 5-1: Unpacking Procedure for Honeywell Versatilis Signal Scout¹

NOTE: After unpacking the signal scout, it is recommended to check for any visible damage to the filter on the face of the sensor. If the filter is damaged then the sensor will not function as intended. In such cases of damaged filter, contact HPS Technical Support through your local Customer Contact Center.

¹The packaging design and information included in this document are related to the proposed prototype, and is yet to be finalized.

The magnetic and adhesive mount adapters are supplied as kits along with Honeywell Versatilis Signal Scout, if chosen the same while ordering.

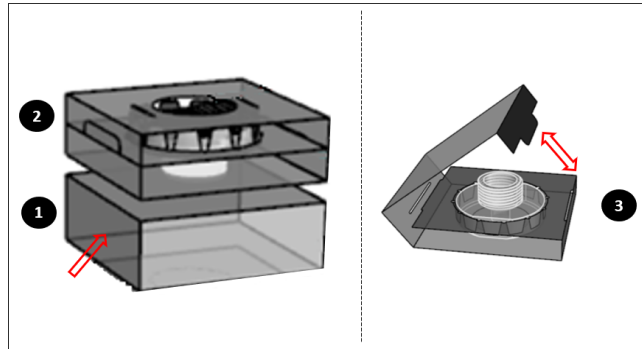

Figure 5-2: Unpacking Mounting Adapters

The following table provides the contents of the Honeywell Versatilis Signal Scout package, while ordering it with each adapter type:

For Signal Scout Ordered with Adapter Type	Contents in the Package	Accessories/ Tools (To be handy with users)
Screw Mount	Honeywell Versatilis Signal Scout fitted with Screw Mount Adapter (Default Option).	<ul style="list-style-type: none"> M6 socket head cap screw and M6 Nut (based on the target structure requirements). Allen key for M6 socket head cap screw, size: 5mm The spanner recommended for the Signal Scout's base is 41mm, and for the Adapter is 32mm.
Magnetic Mount	Honeywell Versatilis Signal Scout, Magnetic Mount Adapter	The spanner recommended for the Signal Scout's base is 41mm, and for the

For Signal Scout Ordered with Adapter Type	Contents in the Package	Accessories/ Tools (To be handy with users)
		Adapter is 32mm.
Adhesive Mount	Honeywell Versatilis Signal Scout, Adhesive Mount Adapter	<p>Recommended cleaning solution for the surface of the target structure: Isopropyl alcohol.</p> <p>The spanner recommended for the Signal Scout's base is 41mm, and for the Adapter is 32mm.</p>

ATTENTION: For disposing off the recyclable Signal Scout and its packaging materials, it is recommended to first remove the battery from the Signal Scout. Then dispose it separately as per the manufacturer's recommendations, and in compliance with the concerned regulations.

Mounting Honeywell Versatilis Signal Scout

Honeywell Versatilis Signal Scout offers multiple mounting options such as Magnetic Mount, Adhesive Mount, and Screw Mount to suit the mounting surface of the target structure, and to ensure good bonding and accurate measurement for the Signal Scout.

NOTE: User needs to select the suitable mounting adapter while placing an order by referring Model Selection Guide (MSG).

The following table includes the list of recommended tools that are required for installation/ replacement scenarios:

Tool	Size
Spanner (for firmly holding the base of Signal Scout while tightening the mounting adapter to it).	41mm
Spanner (for tightening the mounting adapter to the base of the Signal Scout)	32mm
Allen Key and Spanner (for firmly holding the M6 socket head cap screw while tightening with M6 nut respectively)	Depends of the size of M6 socket head cap screw and M6 nut used in the installation.

Pre-installation Considerations

Follow the below procedure when planning to install the Signal Scout for the first time in an identified location or when you are planning to move the installed Signal Scout from an existing location to a new different location.

NOTE: This procedure is not applicable while replacing the Signal Scout in the same location.

1. Uninstall the signal scout from the existing location (in the case of moving to a new location). For more information on how to uninstall, see [Replacement of Honeywell Versatilis Signal Scout](#) (steps 1 and 2).

2. On the new location, mount the Signal Scout with the required adapter on the target structure using recommended mounting bracket (see the mounting instructions below).
3. Calculate/Capture the GPS coordinates for the new location.
4. Pair the Signal Scout using Honeywell Versatilis Connect App, and map the new set of GPS coordinates to the Signal Scout.

Magnetic Mounting

Perform the below instructions for magnetic mounting on the target structure:

ATTENTION: Do not use bare hands while installation as the magnet is powerful and can pinch the skin/ fingers if not handled properly.

1. Screw-in the magnetic mount adapter into the threaded hole provided on the base of the Honeywell Versatilis Signal Scout.
2. Firmly hold the base of the Signal Scout using a spanner (of size 41mm), and tighten the adapter to the base using another spanner (of size 32mm).
Ensure a Torque of 3.5 to 4 Nm is applied for tightening.
3. Attach the Signal Scout fitted with a magnetic mount adapter onto the target structure (like beams, structure, frames, pipes, and etc) with the help of magnetic pull force.

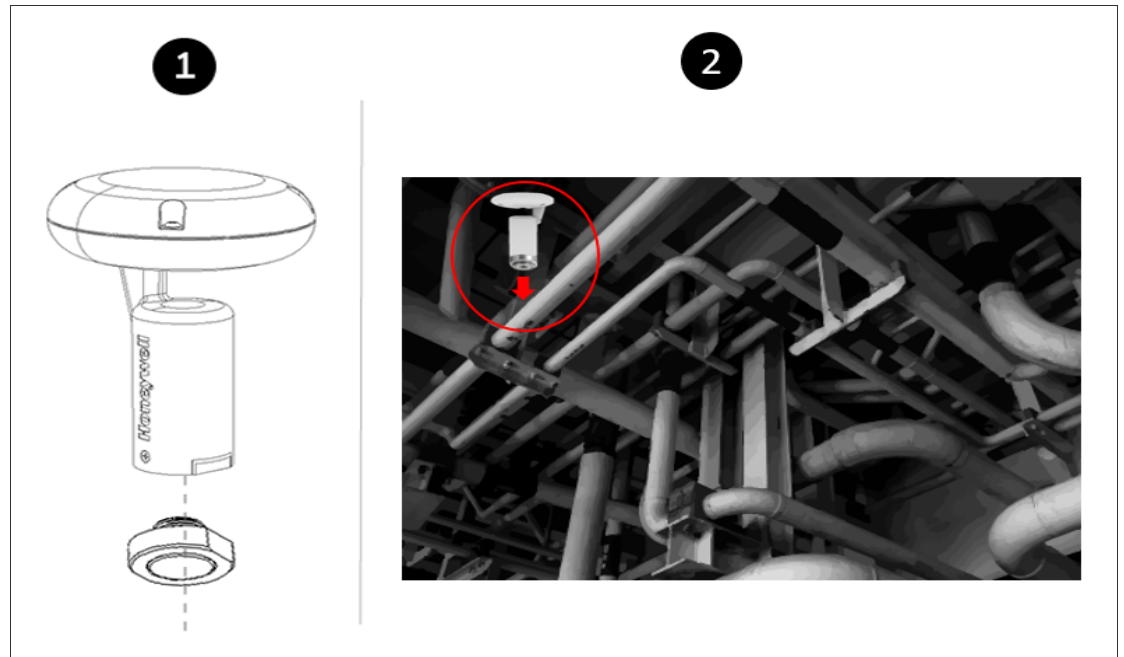

Figure 5-3: Magnetic Adapter Mounting

Adhesive Mounting

Perform the below instructions for adhesive mounting on the target structure:

Prerequisite: Remove oil, moisture, and dirt from the intended mounting surface of the target structure on which the Signal Scout will be mounted. If the dirt is strong, remove it with some plant approved solvent.

ATTENTION: Use the adhesive mounting adapter preferably on a flat surface. As there is a potential risk of falling down of the Signal Scout if it is mounted on uneven, rough, or curved surfaces, due to lack of sufficient bonding area.

1. Screw-in the adhesive mount adapter into the threaded hole provided on the base of the Honeywell Versatilis Signal Scout.
2. Firmly hold the base of the Signal Scout using a spanner (of size 41mm), and tighten the adapter to the base using another spanner (of size 32mm).
Ensure a Torque of 3.5 to 4 Nm is applied for tightening.
3. Remove the protective film from adhesive face of the adapter.

4. Stick the Signal Scout fitted with an adhesive adapter onto the target structure (like beams, structure, frames, pipes, and etc). Apply an adequate pressure on the Signal Scout after it is mounted, to ensure proper bonding of the pressure-sensitive adhesive with the target structure.

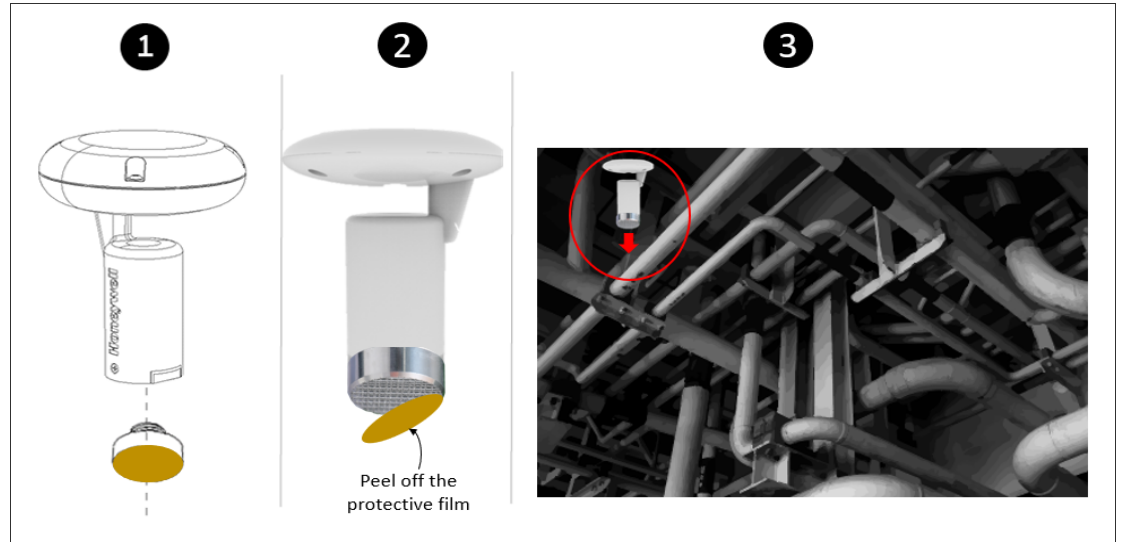

Figure 5-4: Adhesive Adapter Mounting

Screw Mounting

Perform the below instruction for screw mounting on the target structure:

1. Insert the M6 socket head cap screw into the hole provided on the screw-mount adapter (where the head of the screw sits inside the adapter and the shank protrudes outwards).
2. Insert the protruding M6 socket head cap screw (with adapter) into the hole provided on the target structure/bracket, and then secure the adapter with M6 nut (on the other side of structure/bracket) using Allen key and spanner (of required size). Ensure a Torque of 16 N-m or 140 in-lbs is applied for tightening.
Or, If there is an existing M6 tapped hole on the target structure, then you just need to insert the protruding M6 socket head cap screw (with adapter) into that hole provided on the target structure/bracket, and tighten with Allen key (of required size).

3. Fit the Signal Scout onto the secured adapter. Ensure that the orientation of the Signal Scout is vertical. Firmly hold the secured adapter using a spanner (of size 32mm), and tighten the base of the Signal Scout to the adapter using another spanner (of size 41mm). Ensure a Torque of 3.5 to 4 Nm is applied for tightening.

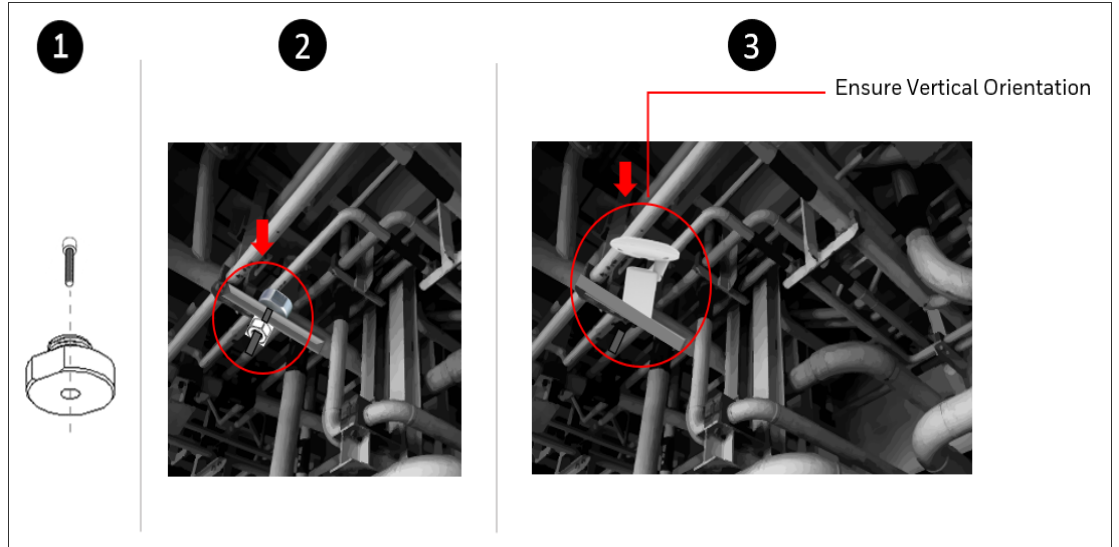

Figure 5-5: Screw-mount Adapter Mounting

CONFIGURATION

The following figure and table provide information about the complete solution architecture designed and implemented for Honeywell Versatilis Signal Scout. This information helps the user to understand the overall process involved, right from the configuration of the Honeywell Versatilis Signal Scout to access the analytic solutions.

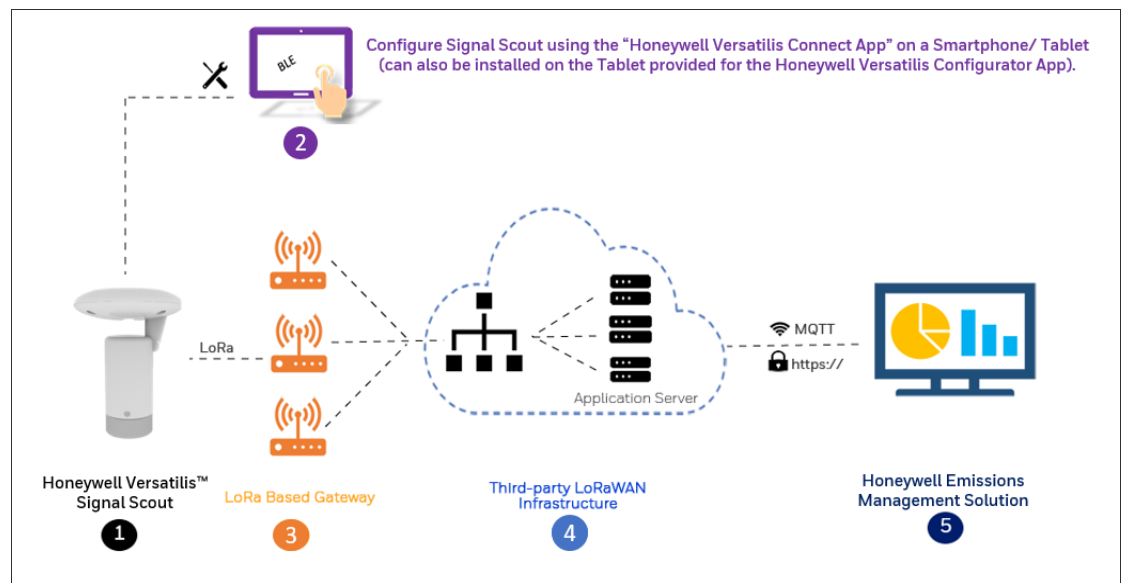

Figure 6-1: Solution Architecture for Honeywell Versatilis Signal Scout

Table 6-1: Description of Solution Architecture Flow

Item	Solution Integration	Description
1	Honeywell Versatilis Signal Scout	The Signal Scout measures the following four parameters: <ul style="list-style-type: none"> • Gas Sensor • Ambient Temperature • Ambient Pressure • Ambient Humidity

Item	Solution Integration	Description
2	Honeywell Versatilis Connect App	The Honeywell Versatilis Connect App enables user to connect to the Signal Scout through bluetooth using a tablet, or smartphone. It helps user to configure the Signal Scout's sensor parameters, view live data, update firmware, etc.
3	LoRa Based Gateway (third-party)	The third-party LoRa based gateways acts as a medium to push the sensor data from the Signal Scout(s) to the LoRaWAN infrastructure in a secured way.
4	LoRaWAN Infrastructure (third-party)	The third-party LoRaWAN Infrastructure applies the payload formatter to encrypt the incoming data from the LoRa gateways, and securely transfer it through the MQTT protocol to the Experion Elevate.
5	Honeywell Emissions Management Solution	Provides the platform to visualize the transmitted emissions data, generates insights, and analytic solutions to improve the efficiency and process control.

Installation of Honeywell Versatilis Connect App

The Honeywell Versatilis Connect app provides flexibility to install it on your Smartphone or Tablet, supporting either Windows or Android-based platforms. You can also make use of your existing Tablet (if any) provided with Honeywell Versatilis Configurator App to install and run the Honeywell Versatilis Connect app on it with ease.

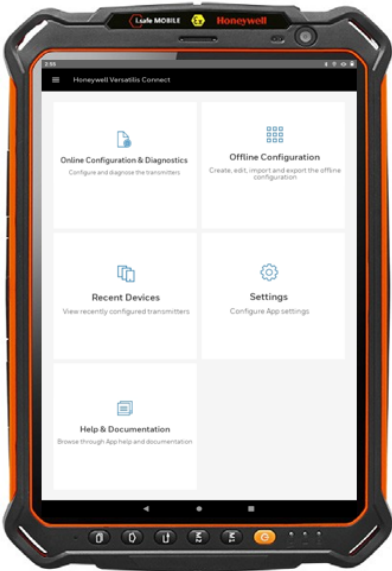

Figure 6-2: "Honeywell Versatilis Connect app" installed on the "Tablet provided with Honeywell Versatilis Configurator App".

Prerequisites:

Table 6-2: Prerequisites for Honeywell Versatilis Connect app:

Tablet/ Smartphone Specifications	Windows	Android
Operating System	Windows 10 or higher versions	Android 10 or higher versions
Process and Speed	64-bit, 1.6GHz or faster	ARM V7 or V8, 1.6GHz or faster
RAM	Minimum: 8GB	Minimum: 4GB

Tablet/ Smartphone Specifications	Windows	Android
		Recommended: 8GB
Storage space	Higher than 64GB is recommended	Higher than 64GB is recommended

To download and install the Honeywell Versatilis Connect app in your Smartphone, Tablet, or PC, follow the procedure described below:

Table 6-3: Installation Procedure for Honeywell Versatilis Connect app

For Windows Platform	For Android Platform
<ol style="list-style-type: none"> 1. Open the Microsoft Store app, and search for "Honeywell Versatilis Connect". 2. Tap Get to install. 3. Tap Open. 	<ol style="list-style-type: none"> 1. Open the Google Play Store app, and search for "Honeywell Versatilis Connect". 2. Tap Install. 3. Tap Open. In the permissions dialog, tap Allow.

When the user launches the Honeywell Versatilis Connect app for the first time, the app gives a tour of its overall features.

For more information on how to configure Signal Scout using Honeywell Versatilis Connect app, see the *Honeywell Versatilis Connect App User's Guide*.

Resetting Passcode for the Honeywell Versatilis Connect app

In case you forgot your current passcode (that is different than the default passcode) to authenticate the login to the Honeywell Versatilis Connect app. You still have an option to reset your current passcode to the default passcode, using the reed switch provided on the Honeywell Versatilis Signal Scout, and thereby able to login to the Honeywell Versatilis Connect app, once again.

Perform the instructions as illustrated in the following figure to reset your current passcode to the default passcode:

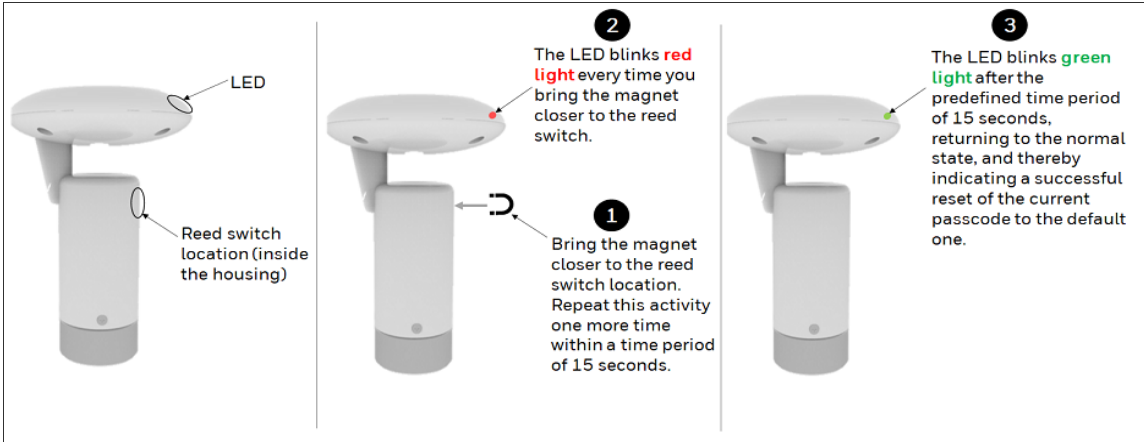

Configure LoRa Gateway

LoRa Gateways acts as communication bridge between Honeywell Versatilis Signal Scout and LoRaWAN application.

NOTE: There are many LoRa based Gateway manufacturers in the market. Choose the LoRa gateway best suited to your needs. For more information on how to set up the LoRa Gateway, refer the respective manufacturer's product documentation.

Following are some common parameters for your reference that needs to be configured for the LoRa gateway:

Functions	Key Parameters
Gateway Device Information	<p>Displays information such as Model Number, Serial Number, IMEI, Frequency Band, Gateway EUI, LAN, WAN, Ethernet, and etc.</p> <p>User can verify these information by checking the same on the sticker provided on the outer panel of the gateway.</p>
LoRaWAN/ Network Settings	<p>Below information needs to be configured:</p> <ul style="list-style-type: none"> • LoRa Mode Selection: Packet Forwarder. Make sure the status of Packet Forwarder shows as "Running". • Network selection: E.g. Radio Bridge ChirpStack, The Things Network, Senet, Loriot, etc. • Frequency Plan selection
Connection Configuration	<p>The available connection options for connecting gateway to the LoRaWAN are Ethernet, Cellular, or Wi-Fi. These options for configuring connections are based on the gateway models as offered by the manufacturer.</p>
After gateway set up	<p>Make sure the gateway is powered ON and connected to the internet. The status should show as Connected in the LoRaWAN service provider application.</p>

Configure LoRaWAN

LoRaWAN is a Low Power, Wide Area (LPWA) networking protocol based on LoRa radio modulation technique. Here, it wirelessly connects battery operated Signal Scout to the internet and manages communication between Signal Scouts and network gateways.

NOTE: There are many LoRaWAN service providers in the market. Choose the LoRaWAN service best suited to your needs. For more information on how to configure Signal Scout and LoRa Gateway in the LoRaWAN service provider application, refer to the respective service provider's product documentation.

LoRa Network (LoRaWAN) Setup

Prerequisite: The following is the list of actions a user needs to do on their own to set up the LoRa network server on-premise:

- A physical PC (mention the specs).
- A licensed VMWare Workstation Pro installed on the PC.
- A licensed LoRa network service or Enterprise version from the LoRaWAN service provider of your choice.
- A VM created with Ubuntu OS (Linux).
- Network server configuration of the LoRaWAN service provider on Ubuntu. For more information on how to configure the LoRa network server (LoRaWAN), refer to the corresponding user documentation on the portal of your LoRaWAN service provider.

The following table provides some common parameters for your reference that needs to be configured in the LoRaWAN service provider's application (UI), after setting up network server (as discussed above):

Functions	Key Parameters
Adding Gateway	Below parameters needs to be configured: <ul style="list-style-type: none"> • Specify a suitable name for the Gateway being added. • Specify a brief description about the Gateway being added. • Specify a unique ID for identifying

Functions	Key Parameters
	<p>the Gateway.</p> <ul style="list-style-type: none"> • Select the required Network-server, and Service-profile. • Enable the Gateway discovery mode.
<p>Creating Device-profile</p>	<ul style="list-style-type: none"> • Specify a suitable name for the Device-profile being created. • Select the required Network-server. • Specify the supported "LoRaWAN MAC version" for the device as "1.0.4". • Specify the supported "LoRaWAN Regional Parameters revision" for the device as "RPO02-1.0.2". • Select the intended network activation method, i.e. ABP/OTAA. • Specify the "RX1 delay" as "5" seconds. • Provide the decoder code to decrypt the encrypted data coming from the device through Gateway. <p>For information on LoRaWAN MAC version, LoRaWAN Regional Parameters revision, Frequency plan, or RX1 delay, see <i>Honeywell Versatilis Signal Scout Technical specification</i> document.</p>
<p>Creating an Application</p>	<ul style="list-style-type: none"> • Specify a suitable name for the Application being created. • Specify a brief description about the Application being created. • Select the required Service-profile.
<p>Adding a Device to the Application</p>	<ul style="list-style-type: none"> • Specify a suitable name for the Device being added to the intended Application. • Specify a brief description about

Functions	Key Parameters
	<p>the Device being added to the intended Application.</p> <ul style="list-style-type: none">• Specify the Device EUI as printed on the enclosure of the Signal Scout, and can also be seen on the About Device page of the Honeywell Versatilis Connect app.• Select the intended Device-profile you want to apply for the Device being added. <p>Provide the activation keys for ABP/OTAA based on your network method selection while adding the Gateway.</p> <p>For example, the following are the keys to specified for the OTAA method:</p> <ul style="list-style-type: none">• LoRa Device EUI: The unique ID as printed on the enclosure of the Signal Scout, and can also be seen on the About Device page of the Honeywell Versatilis Connect app.• LoRa Application EUI: The unique number to identify the Join server during activation. This value can be manually specified or auto-generated from the UI.• LoRa Application key: An application encryption key. This value can be manually specified or auto-generated from the UI. <div data-bbox="865 1556 1373 1787" style="border: 1px solid blue; padding: 5px;"><p>NOTE: Make sure to specify the same activation values in both the Honeywell Versatilis Connect app and LoRaWAN service application UI to accomplish successful network</p></div>

Functions	Key Parameters
	<div style="border: 1px solid blue; padding: 5px; margin-bottom: 10px;">mapping.</div> <p>For more information on how to configure Signal Scout with ABP or OTAA method of LoRaWAN in the Honeywell Versatilis Connect app, see the <i>Honeywell Versatilis Connect App User's Guide</i>.</p>
<p>After all the configuration are done and Gateway is successfully added to the LoRaWAN service provider's application.</p>	<p>Make sure the gateway is powered ON and connected to the internet. The status should show as Connected in the LoRaWAN service provider's application.</p>

The following is the flow diagram of the LoRa Network configuration process:

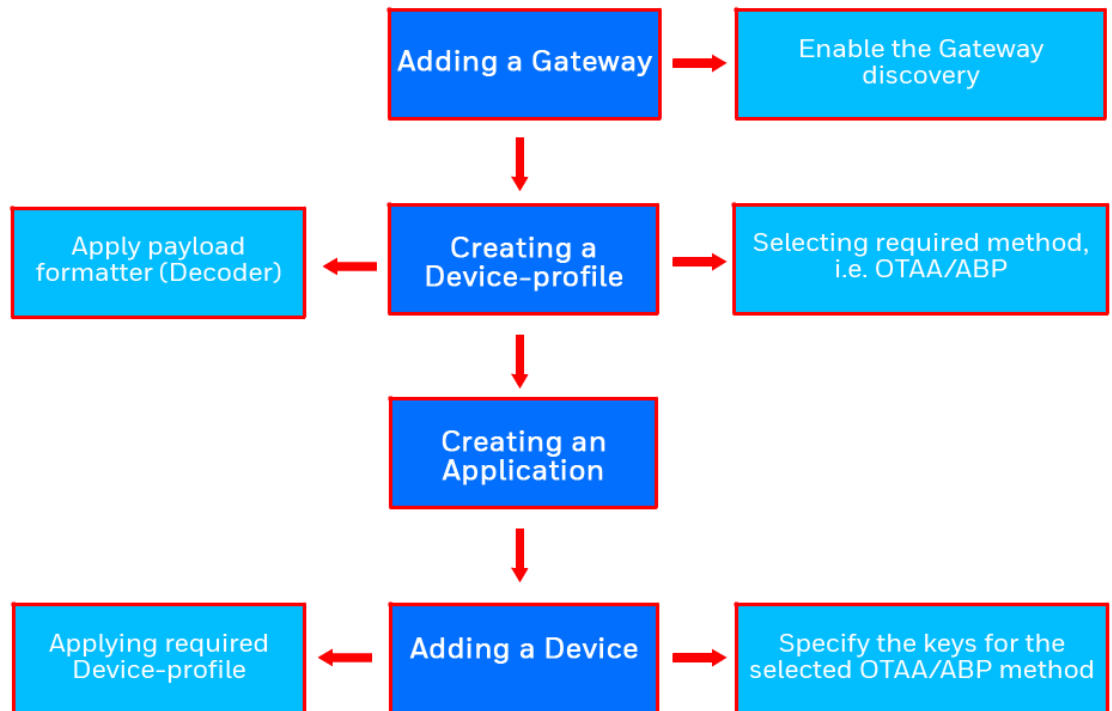

Figure 6-3: LoRa Network Configuration Process - Flow Diagram

Honeywell Emissions Management Solution

Honeywell Emissions Management Solution provides the platform to visualize the transmitted emissions data, generates insights, and analytic solutions to improve the efficiency and process control.

For more information on how to use Honeywell Emissions Management Solution features, see the "Using Honeywell Emissions Management Solution" section in the *Experion Operator's Guide*.

SECURITY

The security mechanisms implementation rely on the well tested and cryptographic algorithms, which are analyzed by the cryptographic community, NIST approved, and widely adopted as a best security for constrained nodes and networks.

To report a potential security vulnerability against any Honeywell product, please follow the instructions as mentioned in the [Notices](#).

Security features

The secure features of the Honeywell Versatilis Signal Scout are:

- Secure firmware update.
- Secure end-to-end Bluetooth and LoRa (i.e., secure data communication by application payload and pairing).
- IP protection feature to secure flash contents.
- Data protection, Data integrity, and Confidentiality protection.
- Authentication on the BLE security using passkey.
- Communication encryption as per BLE 5.0 version.
- Supports LoRaWAN® Class-A security using Over The Air Activation (OTAA).

Physical security

Keys are persistently stored in the Honeywell Versatilis Signal Scout and their protection depends on the Signal Scout's physical security. If the Signal Scout is subject to physical threats, keys can be protected in tamper-resistant storage (secure element), where the extraction is extremely difficult.

MAINTENANCE

In this section:

<i>Replacement of Honeywell Versatilis Signal Scout</i>	<i>38</i>
<i>Firmware update</i>	<i>38</i>
<i>System logs</i>	<i>38</i>

Replacement of Honeywell Versatilis Signal Scout

The modularized design of the Honeywell Versatilis Signal Scout allows the user to disassemble the Signal Scout from the current target structure and to mount on some other target structure with ease, or to replace the currently fitted mounting adapter with some other adapter to suit the change in mounting surface.

Perform the below instructions to replace the Honeywell Versatilis Signal Scout:

1. Detach the Signal Scout from the target structure:
 - In case of screw-mount: Remove the M6 nut securing the Signal Scout onto the target structure.
 - In case of magnetic mount: Remove the Signal Scout from the target structure manually.
 - In case of adhesive mount: Cut through the adhesive layer (sticking the adapter to the target structure) using a blade.
2. Firmly hold the base of the Signal Scout using a spanner (of size 41mm), and unscrew the adapter from the base of the Signal Scout using another spanner (of size 32mm) till it's completely disassembled.
3. Install the Honeywell Versatilis Signal Scout with the required mounting adapter. For information on mounting procedure for Honeywell Versatilis Signal Scout with various adapter types, see "Mounting Honeywell Versatilis Signal Scout " on page 20.

Firmware update

The Honeywell Versatilis Connect app has provision to update to the latest firmware available for the Honeywell Versatilis Signal Scout. For more information on how to update firmware, see the *Honeywell Versatilis Connect App User's Guide, 34-VT-25-03*.

System logs



User has the provision to download the Signal Scout's log files and save it to the local drive using Honeywell Versatilis Connect App.





For more information on how to download logs using Honeywell Versatilis Connect app, see the *Honeywell Versatilis Connect App User's Guide, 34-VT-25-03*.





LED STATES

The following table provides various states of Signal Scout's LEDs and their associated status based on different scenarios.

Table 9-1: LEDs States

Probable Scenarios	Honeywell Versatilis Signal Scout Status	LED
On inserting the battery at the factory.	Power ON	 (Blinks thrice.)
	Power ON failure.	No visual indication on LED.
Connecting to the Signal Scout using Bluetooth scan in Honeywell Versatilis Connect app.	Successful pairing.	 (Blinks once.)
User selects the Signal Scout from the list of "Available Devices" displayed on the Honeywell Versatilis Connect app.	Unsuccessful pairing.	 (Blinks once.)
	Not recognizing.	No visual indication on LED.

Probable Scenarios	Honeywell Versatilis Signal Scout Status	LED
Connecting to the Signal Scout using QR code scan in the Honeywell Versatilis Connect app.	Successful pairing.	 (Blinks once.)
Scanning QR code imprinted on the Signal Scout, flashes the Signal Scout's summary in the Honeywell Versatilis Connect app.	Unsuccessful pairing.	 (Blinks once.)
	Not recognizing.	No visual indication on LED.
User activates the Signal Scout to start measuring parameters, or pushing configurations to the Signal Scout as required from the Honeywell Versatilis Connect app.	During configuration	
On successful configuration of the Signal Scout .	Configuration successful.	 (Blinks thrice.)
Configuring the Signal Scout using "Offline Template".	Configuration failure.	 (Blinks thrice.)



Probable Scenarios	Honeywell Versatilis Signal Scout Status	LED
Turning ON/ OFF LED - Preconfigured.	On activation.	 (Blinks thrice.)
	Dormant	No visual indication on LED.
Turning ON/ OFF LED - Using reed switch.	On activation.	 (Blinks thrice.)
	Dormant	 (Blinks once.)
Firmware update	While downloading/updating.	 (Blinks for every 10 seconds.)
	Successful updating, and restarting.	 (Blinks thrice.)

Probable Scenarios	Honeywell Versatilis Signal Scout Status	LED
	Unsuccessful	 (Blinks thrice.)

TROUBLESHOOTING

The following table provides various troubleshooting scenarios in the case of error or unexpected behavior, and their corresponding troubleshooting tips:

Table 10-1: Troubleshooting Information

Probable Scenarios	Honeywell Versatilis Signal Scout Status	LED	On Screen	Troubleshooting Tips
User selects the Signal Scout from the list displayed on the Honeywell Versatilis Connect app.	Unsuccessful pairing.	 (Blinks once.)	A pop-up window prompts to try again.	<ul style="list-style-type: none"> • Retry pairing. • Verify the passkey specified for Honeywell Versatilis Connect app authentication.
	Not recognizing.	No visual indication on LED.		Ensure that the device is in within the BLE range.
Scanning QR code imprinted on the Signal Scout, flashes the Signal Scout's summary.	Unsuccessful pairing.	 (Blinks once.)	A pop-up window prompts to try again.	<ul style="list-style-type: none"> • Re-scan the QR code. • Connect manually through BLE app.
	Not recognizing.	No visual indication on LED.	NA	
Firmware update	Unsuccessful		A pop-up window with error message	<ul style="list-style-type: none"> • Authenticate complete file content at the

Probable Scenarios	Honeywell Versatilis Signal Scout Status	LED	On Screen	Troubleshooting Tips
		(Blinks thrice.)	appears.	<p>end.</p> <ul style="list-style-type: none"> • Check source file, or contact Honeywell TAC team.
Diagnostic fault indication.	Battery low.	No visual indication on LED.	Low Battery indication on Diagnostic page of Honeywell Versatilis Connect app and Experion EHM.	Signal Scout replacement.
	Sensor interface failure.		Status indicator at sensor level as well as on the Diagnostic page of Honeywell Versatilis Connect app and Experion EHM.	<ul style="list-style-type: none"> • Restart Signal Scout. • Replace Signal Scout.
	LoRa communication status.		Communication fault indication on the Diagnostic page of Honeywell Versatilis Connect app and Experion EHM.	<ul style="list-style-type: none"> • Install the Gateway within the reachable range of the device as per the LoRaWAN standard. • Ensure the device is configured in the LoRaWAN server with

Probable Scenarios	Honeywell Versatilis Signal Scout Status	LED	On Screen	Troubleshooting Tips
				<p>valid keys (for ABP/OTAA method).</p> <ul style="list-style-type: none"> • Ensure the device is configured in Honeywell Versatilis Connect app with valid keys (for ABP/OTAA method). • Ensure the keys specified in Honeywell Versatilis Connect app and LoRaWAN server are the same. • Ensure valid LoRa reporting interval is set in Honeywell Versatilis Connect app. • Restart Signal Scout.

CERTIFICATIONS

Hazardous Location Certifications

Honeywell Versatilis Signal Scout is certified for various hazardous location standards and requirements.

The below table gives the summary on the same:

Table 11-1: Hazardous Location Certifications Information

Certification	Standards	Approval/ Rating
IECEX	IEC 60079-0/COR1: 2020; Edition 7.0; 2017-12 IEC 60079-11: Edition 6.0; 2011-06	Ex ia IIB T4 Ga Tamb: -40°C to +70°C
CE - ATEX (2014/34/EU)	EN 60079-0: 2018 EN 60079-11: 2012	II 1 G - Ex ia IIB T4 Ga Tamb: -40°C to +70°C
UKCA Ex	EN 60079-0: 2018 EN 60079-11: 2012	II 1 G - Ex ia IIB T4 Ga Tamb: -40°C to +70°C
North America	CAN/CSA C22.2 No. 61010-1- 12 + UPD1: 2015, UPD2: 2016, AMD 1-18 CAN/CSA C22.2 No. 60079-0: 19 CAN/CSA-C22.2 No. 60079-11: 14 (R2018) ANSI/UL 61010-1-2018 Third Edition	Class I Division 1, Group C, D Ex ia IIB T4 Ga Class I Zone O, AEx ia IIB T4 Ga Tamb: -40°C

Certification	Standards	Approval/ Rating
	ANSI/UL 913-2019 Eighth Edition ANSI/UL 60079-0-2020 Seventh Edition ANSI/UL 60079-11-2018 Sixth Edition	to +70°C
CCoE	IS/IEC 60079-0: 2017 IS/IEC 60079-11: 2011	Ex ia IIB T4 Ga Tamb: -40°C to +70°C

Specific Conditions of Use:

- The nonmetallic enclosure parts of this equipment may become a spark ignition hazard in the presence of static electricity. The enclosure shall be cleaned only with a damp cloth, and the equipment shall be mounted to avoid building static electric charge from non-conductive process flow, strong air currents, or other potential charging through friction.
- Honeywell Versatilis Signal Scout (ED) - Model 50187700-100, detects flammable gas, however, is not intended to provide an indication, alarm, or other output function; purpose of which is to indicate potential hazard and initiate automatic or manual protective action(s).
- The aluminum enclosure may be capable of producing incendive sparks when impacted. This equipment must be mounted and/or physically guarded such that it is not subjected to impact or friction.

**WARNING: DO NOT REPLACE BATTERY WHEN AN EXPLOSIVE ENVIRONMENT IS PRESENT.
USE ONLY "ER34615C BATTERY FROM EVE Energy Co., Ltd".**

CE (Conformance to Europe)

Honeywell Versatilis Signal Scout is compliant with all the Directives that are applicable as per CE certification requirements.

The below table gives the summary on the same:

Table 11-2: CE (Conformance to Europe) Information

Certification	Standards	Directive/ Regulation
CE	EN 61326-1: 2013 EN 61326-2-3: 2013 EN55011: 2009 + A1: 2010 EN 61000-4-2: 2009 EN 61000-4-3: 2006+A1+A2 EN 61000-4-8: 2010	Electro Magnetic Compatibility (EMC) Directive; 2014/30/EU
CE	ETSI EN 300 328 ETSI EN 300 220-1 V3.1.1 (2017-02) ETSI EN 300 220-2 V3.1.1 (2017-02) ETSI EN 301 489-1: 2019 ETSI EN 301 489-3: 2021 ETSI EN 301 489-17: 2020	Radio Equipment Directive (RED); 2014/53/EU
CE	EN 61010-1: 2010/A1: 2019	Low Voltage Directive (LVD); 2014/35/EU
CE	EN 50581: 2012	Restriction of use of Hazardous Substances (RoHS) in Electrical and Electronic

Certification	Standards	Directive/ Regulation
		equipment; 2011/65/EU; 2017/2102 amendment
CE	EN 50385: 2017	Minimum health and safety requirements regarding the exposure of workers to the risks arising from physical agents (Electromagnetic fields); 2013/35/EU

United Kingdom Conformity Assessed (UKCA)

Honeywell Versatilis Signal Scout is compliant with all the regulations that are applicable as per UKCA certification requirements.

The below table gives the summary on the same:

Table 11-3: United Kingdom Conformity Assessed (UKCA) Information

Certification	Standards	Directive/ Regulation
UKCA	EN 61326-1: 2013 EN 61326-2-3: 2013 EN55011: 2009 + A1: 2010 EN 61000-4-2: 2009 EN 61000-4-3: 2006+A1+A2 EN 61000-4-8: 2010	Electro Magnetic Compatibility (EMC) Regulations 2016

Certification	Standards	Directive/ Regulation
UKCA	ETSI EN 300 328 ETSI EN 300 220-1 V3.1.1 (2017-02) ETSI EN 300 220-2 V3.1.1 (2017-02) ETSI EN 301 489-1: 2019 ETSI EN 301 489-3: 2021 ETSI EN 301 489-17: 2020	Radio Equipment Regulations 2017
UKCA	EN 61010-1: 2010/A1: 2019	Electrical Equipment (Safety) Regulations 2016
UKCA	EN 50581: 2012	Restriction of the Use of Certain Hazardous Substances (RoHS) in Electrical and Electronic Equipment Regulations 2012
UKCA	EN 50385: 2017	The Control of Electromagnetic Fields at work Regulations 2016

FCC and IC Certifications

Honeywell Versatilis Signal Scout is compliant with all the requirements that are applicable as per FCC & IC certification specifications.

The below table gives the summary on the same:

Table 11-4: FCC and IC Certifications Information

Certification	Standard	Approval/ Rating
FCC	47 CFR Part 15 [10-01-20 Edition] ANSI C63.4: 2014	Compliance as per Subpart B & Subpart C FCC ID: S5751490045 BLE FCC ID: 2APD9-RSL10SIP
IC	ICES-003 Issue 7: 2020 ICES-Gen Issue 1: 2018+A1: 2021 RSS-247 Issue 2 Equipment Certification	Compliant for Wireless requirements IC ID: 573W-51490045 BLE IC ID: 23763-RSL10SIP

This device complies with Part 15 of the FCC Rules. Operation is subject to the following two conditions:

- This device may not cause harmful interference, and
- This device must accept any interference received, including interference that may cause undesired operation.

WARNING: Changes or modifications to this unit not expressly approved by the party responsible for compliance could void the user's authority to operate the equipment.

NOTE: This equipment has been tested and found to comply with the limits for a Class B digital device, pursuant to Part 15 of the FCC Rules. These limits are designed to provide reasonable protection against harmful interference in a residential installation.

This equipment generates, uses, and can radiate radio frequency energy and, if not installed and used in accordance with the instructions, may cause harmful interference to radio communications. However, there is no guarantee that interference will not occur in a particular installation. If this equipment does cause harmful interference to radio reception, which can be determined by turning the equipment OFF and ON, the user is encouraged to try to correct the interference by one or more of the following measures:

- Reorient or relocate the receiving antenna.
- Increase the separation between the equipment and receiver.
- Consult the dealer or an experienced radio technician for help.

NOTE:

This device contains licence-exempt transmitter(s)/receiver(s) that comply with Innovation, Science and Economic Development Canada's licence-exempt RSS(s). Operation is subject to the following two conditions:

- * This device may not cause interference.
- * This device must accept any interference, including interference that may cause undesired operation of the device.

L'émetteur/récepteur exempt de licence contenu dans le présent appareil est conforme aux CNR d'Innovation, Sciences et Développement économique Canada applicables aux appareils radio exempts de licence. L'exploitation est autorisée aux deux conditions suivantes:

- * L'appareil ne doit pas produire de brouillage;
- * L'appareil doit accepter tout brouillage radioélectrique subi, même si le brouillage est susceptible d'en compromettre le fonctionnement.

CAUTION: To maintain compliance with the FCC's RF exposure guidelines, place the unit at least 20cm from nearby persons.

Wireless Certifications and Approvals

Honeywell Versatilis Signal Scout has LoRaWAN & BLE Wireless communication technologies. Required certifications and approvals have been attained for this product.

The below table gives the summary on the same:

Table 11-5: Wireless Certifications and Approvals Information

Certification	Standard/ Specification	Approval
LoRaWAN	LoRaWAN 1.0.4	End device certification requirements for all regions: Version 1.4
Bluetooth Low Energy (BLE)	Bluetooth Specifications	Bluetooth SIG Listed

NOTICES

Trademarks

Microsoft is a registered trademark or trademark of Microsoft Corporation in the United States and/or other countries.

Trademarks that appear in this document are used only to the benefit of the trademark owner, with no intention of trademark infringement.

Other trademarks

Other brands or trademarks are trademarks of their respective owners.

Trademarks that appear in this document are used only to the benefit of the trademark owner, with no intention of trademark infringement.

Third-party licenses

This product may contain or be derived from materials, including software, of third parties. The third party materials may be subject to licenses, notices, restrictions and obligations imposed by the licensor. The licenses, notices, restrictions and obligations, if any, may be found in the materials accompanying the product, in the documents or files accompanying such third party materials, in a file named third_party_licenses on the media containing the product.

Documentation feedback

You can find the most up-to-date documents in the Support section of the Honeywell Process Solutions website at:

<https://process.honeywell.com>

If you have comments about Honeywell Process Solutions documentation, send your feedback to: hpsdocs@honeywell.com

Use this email address to provide feedback, or to report errors and omissions in the documentation. For immediate help with a technical problem, contact HPS Technical Support through your local Customer Contact Center, or by raising a support request on the Honeywell Process Solutions Support website.

How to report a security vulnerability

For the purpose of submission, a security vulnerability is defined as a software defect or weakness that can be exploited to reduce the operational or security capabilities of the software.

Honeywell investigates all reports of security vulnerabilities affecting Honeywell products and services.

To report a potential security vulnerability against any Honeywell product, please follow the instructions at:

<https://honeywell.com/pages/vulnerabilityreporting.aspx>.

Submit the requested information to Honeywell using one of the following methods:

- Send an email to security@honeywell.com.
- Contact your local Honeywell Technical Assistance Center (TAC) listed in the “Support” section of this document.

Support

For support, contact your local Honeywell Process Solutions Customer Contact Center (CCC). To find your local CCC visit the website, <https://process.honeywell.com/us/en/contact-us>.

Training classes

Honeywell holds technical training classes that are taught by process control systems experts. For more information about these classes, contact your Honeywell representative, or see <http://www.automationcollege.com>.

Factory information

Honeywell International (India) Pvt. Ltd., Plot No. 2, Gat No. 181, Village Fulgaon, Tal-Haveli, Pune, Maharashtra, 412216, India.