



1-LDC See-Thru Liquid Drainer

For Loads to 690 kg/h...Pressures to 10 bar

Now, you can literally see what you've been missing – the early warning signs of a drain trap or system problem. Since you'll know the operating condition of a drain trap, you won't waste time and money scheduling maintenance that isn't needed. In other words, you'll be able to react to a condition before it becomes a problem.

A simple ball float mechanism needing no electricity to operate, the 1-LDC discharges automatically only when liquid is present. That means no air loss as with timed devices that open even when liquid is not present. Moisture in a compressed air system causes problems. Getting the water out – automatically, reliably – builds greater efficiency into your system.

Table LD-344-1. 1-LDC List of Materials	
Name of Part	Material
Cap and Fitting	Reinforced Nylon*
Body	Polysulfone
O-Rings (Cap, Body and Fitting)	Nitrile Elastomer Compound
Float, Lever and Screws	Stainless Steel
Valve & Seat	
Retainer Ring	Zinc-Plated Steel

* UV sensitive

Table LD-344-2. 1-LDC Maximum Operation Pressures and Capacities				
Specific Gravity	1,0		0,95	
	Maximum Operating Pressure	Capacity	Maximum Operating Pressure	Capacity
Orifice Size	bar	kg/h	bar	kg/h
	1/8"	8,3	690	7,6
#38	10,0	510	10,0	490

Capacities given are continuous discharge capacities in kg/h of liquid at pressure differential indicated.

Table LD-344-3. 1-LDC Physical Data	
Inlet Connections (screwed NPT)	mm
	15 - 20
Outlet Connection (screwed NPT)	15
Alternate Inlet or Vent Connection (screwed NPT)	15 - 20
"A"	89
"B"	175
"C"	155
Weight in kg (screwed NPT)	0,45
Maximum Allowable Pressure (Vessel Design)	10 bar @ 65°C
Maximum Operating Pressure	10 bar

All sizes comply with the article 4.3 of the PED (2014/68/UE).

How to Order

Body Inlet ①	Cap Inlet ②	Cap Outlet ③
20	15	15
15 or 20	15 or 20	15

Liquid Drainers

Figure LD-344-1. Typical Drain Trap Location

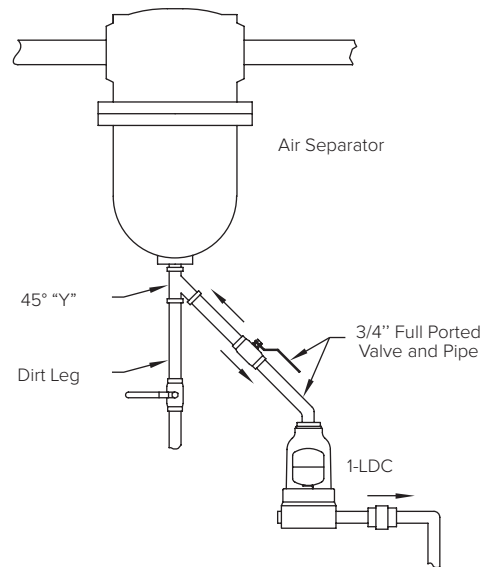

Drain traps dispose of water that collects in many places in a compressed air system. Each drain trap arrangement must be considered individually.

Figure LD-344-2.

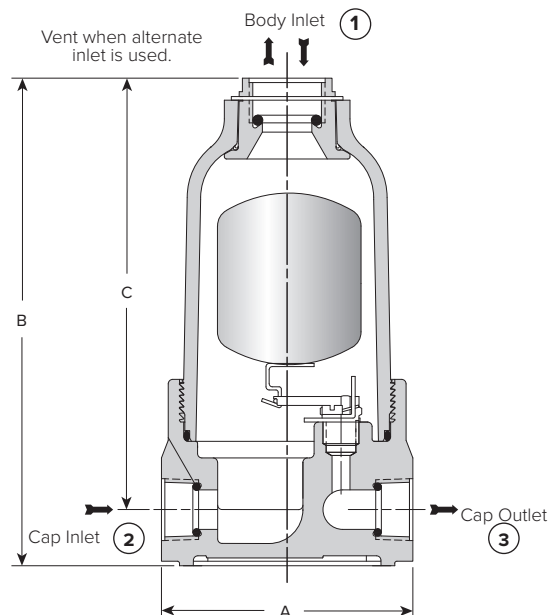

All dimensions and weights are approximate. Use certified print for exact dimensions. Design and materials are subject to change without notice.