

RB 1700 RB 1800

Commercial & Industrial Regulator



The RB 1700 / RB 1800 series of regulators is designed for commercial applications, appliance pressure regulation, secondary regulation of plant distribution piping, and all installations with continuous consumption and rapid flow rate variations, such as burners, industrial ovens, boilers, etc.

DESCRIPTION

The RB 1700 or RB 1800 regulator is a direct-acting, spring-loaded regulator with an optional integrated safety shut-off device. Its balanced valve design ensures constant outlet pressure when the upstream pressure varies.

An optional built-in shut-off valve offers protection against overpressure and over-and-under-pressure. Its bypass system eases the shut-off valve relatching.

KEY BENEFITS

- » High flow accuracy
- » Easy maintenance
- » Rugged construction for durability
- » Balanced valve design eliminates inlet pressure effect
- » EN 334 compliant

Technical Features

Inlet pressure	19 bar	
Outlet pressure	RB 1700	0.12 bar - 2.5 bar
	RB 1800	19 mbar - 2.5 bar
Accuracy & lock-up pressure	Up to AC5 / up to SG10	
Operating temperature	-20°C to +60°C	
Ambient temperature	-30°C to +60°C (body material)	
Acceptable gases	Natural gas, town gas, propane, butane, air, nitrogen or any non corrosive gas	
Safety devices	Optional built-in safety shut-off valve: over-pressure shut-off (OPSO) and under-pressure shut-off (UPSO) Optional creep relief valve (only on RB 1800)	
Options	Monitor version	

Sizes & Connections

Body sizes	1" - 1½"	
Connections	Parallel thread ISO 7 or ISO 228, NPT Flanged DN 25 - PN 20 or 25	⇒ RB 1700
	Flanged DN 40 or 50 - PN 20 or 25	⇒ RB 1800 Ma-
Body	Spheroidal graphite cast iron ISO 1083 gr 500-7	
Head	Pressed steel UNI EN 10025	
Internal parts	Stainless steel and brass	
Seals	Nitrile rubber	
Diaphragm	Synthetic rubber with fabric reinforcement	

RB 1700 / RB 1800 Operational Diagram

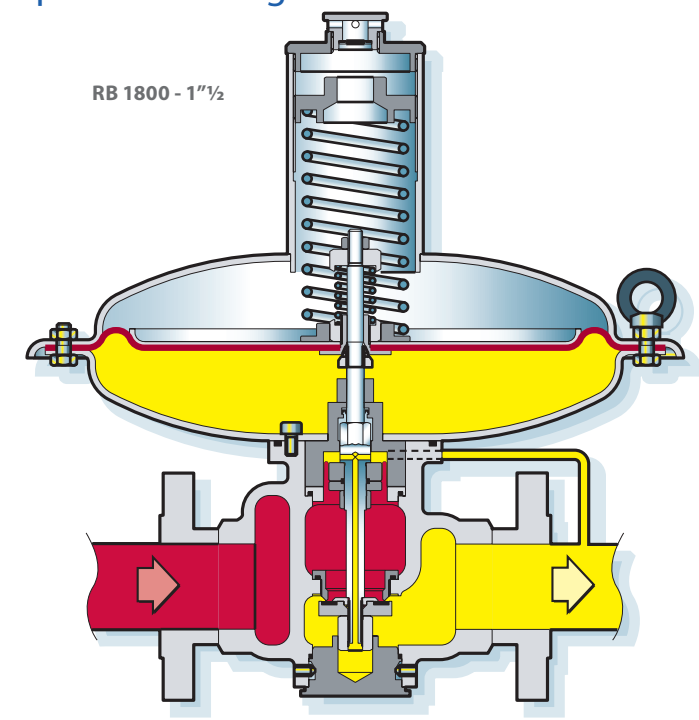

■ Inlet Pressure
■ Outlet Pressure

RB 1700 - 1"

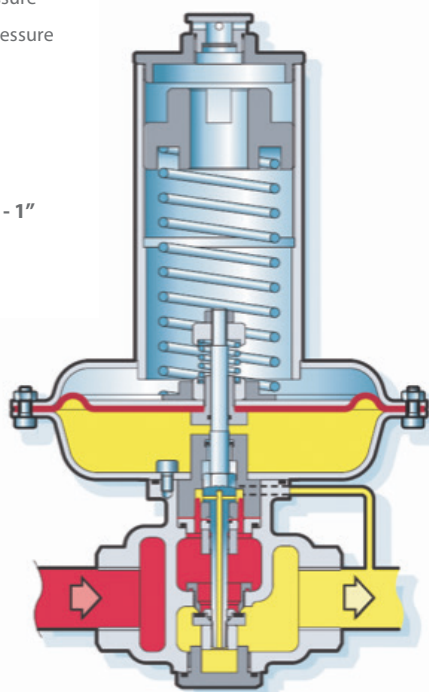

Accuracy class (AC), lock-up pressure class (SG) and lock-up pressure zone:

- » RB 181x up to AC 5 / SG 10
- » RB 172x / RB 182x up to AC 5 / SG 10
- » RB 173x / RB 183x up to AC 10 / SG 20

The typical lock-up pressure zone is:

$$\frac{Q_{\min, P}}{Q_{\max, Pe}} = \frac{2.5}{100}$$

SAFETY SHUT-OFF VALVE Operational Diagram

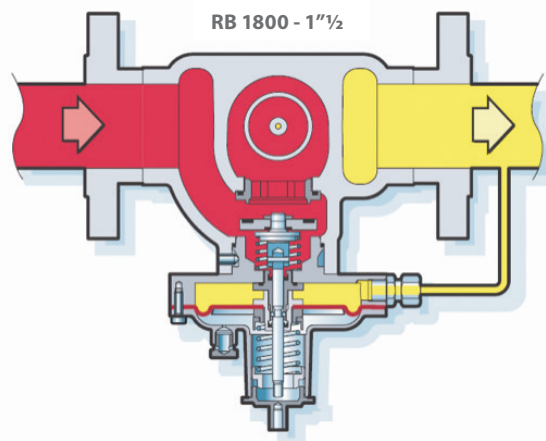

■ Inlet Pressure
■ Outlet Pressure

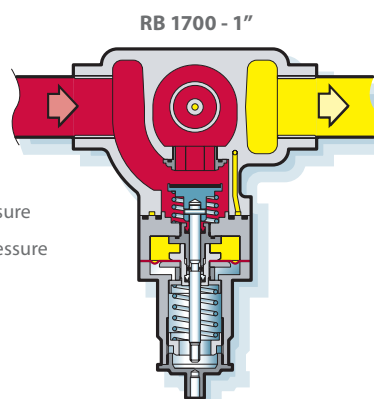

The RB 1700 / RB 1800 series of regulators can be fitted with safety shut-off valve for overpressure (OPSO) or combined under-and-over pressure (UPSO/OPSO) protection.

The SSV trip pressure can easily be adjusted independently of the regulator set point.

The closing plug of the SSV controller is used as pulling tool to relatch the valve.

A built-in bypass, for balancing pressure before relatching the safety shut-off valve, is operated by pulling the valve stem.

Accuracy class (AG)

- » SSV Ø 60 0.3 - 4 bar AG 10
- » SSV Ø 120 32 - 200 mbar AG 30
- » SSV Ø 120 200 - 370 mbar AG 5
- » SSV Ø 90 0.15 - 4.2 bar AG 5

Minimal difference between regulator and SSV settings (ΔP_w):

- » 15% of set point with a minimum difference of 10 mbar to UPSO, 20 mbar to OPSO.

OUTLET PRESSURE RANGE

RB 1700

Spring Code	Spring Characteristic					Spring Range	
	d (mm)	Di (mm)	Lo (mm)	Lt	Colour	1720 - 1721 - 1722 (Ø 220)	1730 - 1731 - 1732 (Ø 220/TR)
20567663	5.5	43	160	10.5	Lilac	0.12 - 0.30 bar	
20567664	6.5	43	160	10.5	Orange	0.20 - 0.55 bar	
20567665	7	43	160	10.5	Brown	0.30 - 0.65 bar	0.50 - 1.00 bar
20567666	7.5	43	160	10.5	Green	0.40 - 0.90 bar	0.60 - 1.40 bar
20567761	8	43	140	9	Black	-	0.80 - 1.50 bar
20567762	9	43	140	9	Grey	-	1.10 - 2.30 bar

Safety Shut-off Valves

Over Pressure Shut-off Springs (OPSO)

Spring Code	Spring Characteristic				Lt	Spring Range	
	d (mm)	De (mm)	Lo (mm)	Colour		1721 - 1722 - 1731 - 1732 (Ø 60)	
20563124	2.2	25	35	5.5		0.3 - 0.6 bar	
20563121	2.5	25	35	5		0.5 - 1.1 bar	
20563115	3	25	35	5.5		1.1 - 2.1 bar	
20563116	3	25	35	5.5		2.0 - 4.0 bar	

Under Pressure Shut-off Springs (UPSO)

					1722 - 1732	
20560516	1	10	30	5.5		0.10 - 0.22 bar
20560517	1.2	10	30	5		0.22 - 0.45 bar

RB 1800

Spring Code	Spring Characteristic					Spring Range		
	d (mm)	Di (mm)	Lo (mm)	Lt	Colour	1810/11/12 (Ø 360)	1820/21/22 (Ø 220)	1830/31/32 (Ø 220/TR)
20567075	3.5	43	200	15.5	Yellow	19 - 25 mbar	-	
20567076	3.5	43	200	10.75	Red	24 - 32 mbar	-	
20567662	4.5	43	160	11	White	27 - 53 mbar	-	
20567663	5.5	43	160	10.5	Lilac	52 - 100 mbar	0.12 - 0.37 bar	
20567664	6.5	43	160	10.5	Orange	90 - 210 mbar	0.23 - 0.60 bar	
20567665	7	43	140	10.5	Brown	-	0.31 - 0.65 bar	0.50 - 1.00 bar
20567666	7.5	43	160	10.5	Green	-	0.40 - 0.90 bar	0.60 - 1.35 bar
20567761	8	43	140	9	Black	-	-	1.10 - 1.70 bar
20567762	9	43	140	9	Grey	-	-	1.10 - 2.50 bar

Safety Shut-off Valves

Over Pressure Shut-off Springs (OPSO)

Spring Code	Spring Characteristic				Lt	Spring Range		
	d (mm)	De (mm)	Lo (mm)	Colour		1811 - 1812 (Ø 120)	1821 - 1822 (Ø 90)	1831 - 1832 (Ø 90 TR)
20563022	1.5	25	35	5.5		32 - 60 mbar	-	
20563023	1.7	25	35	5.5		46 - 80 mbar	-	
20563014	1.9	25	35	5.5		70 - 125 mbar	-	
20563124	2.2	25	35	5.5		125 - 220 mbar	-	
20563121	2.5	25	35	5		210 - 370 mbar	-	
20565225	2	35	50	6		-	0.15 - 0.16 bar	
20565125	2.5	35	50	6		-	0.16 - 0.38 bar	
20565126	3	35	50	6		-	0.38 - 0.80 bar	0.65 - 1.27 bar
20565127	3.5	35	50	6		-	0.80 - 1.60 bar	1.25 - 2.60 bar
20565128	4	35	50	6		-	-	2.30 - 4.20 bar

Under Pressure Shut-off Springs (UPSO)

					1812	1822	1832
20560515	0.8	10	30	10	10 - 14 mbar	-	
20560518	0.9	10	30	10	14 - 32 mbar	-	
20560516	1	10	30	10	32 - 56 mbar	-	
20561022	1.2	15	35	7.75	-	0.05 - 0.055 bar	
20560815	1.3	15	35	8	-	0.055 - 0.085 bar	
20561023	1.5	15	35	7.75	-	0.08 - 0.18 bar	
20561024	1.8	15	35	7.5	-	0.15 - 0.37 bar	0.25 - 0.60 bar
20561121	2	15	35	7.25	-	0.32 - 0.73 bar	0.42 - 1.09 bar
20561122	2.5	15	35	7.25	-	-	1.08 - 2.70 bar

Relief Valve

The built-in relief valve is set 10 mbar above the outlet pressure setting. Other settings on request.

Spring characteristics: d:

wire diameter
De: external diameter
Di: internal diameter

Lo: height
Lt: no. of spires

FLOW CAPACITY

The following tables give the maximum flow capacity - in m³/h at standard conditions - of RB 1700 / RB 1800 regulators. More data are available in the leaflets "RB 1700 Capacity Tables" and "RB 1800 Capacity Tables".

Inlet Pressure	RB 1700		Inlet Pressure	RB 1720		Inlet Pressure	RB 1730	
	Outlet Pressure Setting			Outlet Pressure Setting			Outlet Pressure Setting	
	150 mbar	300 mbar		500 mbar	800 mbar		1500 mbar	2000 mbar
250 mbar	60	-	250 mbar	-	-	250 mbar	-	-
500 mbar	110	95	500 mbar	-	-	500 mbar	-	-
700 mbar	150	130	700 mbar	110	-	700 mbar	-	-
1 bar	190	180	1 bar	180	120	1 bar	-	-
1.5 bar	240	240	1.5 bar	240	240	1.5 bar	-	-
3 bar	300	320	3 bar	320	320	3 bar	220	-
5 bar	400	420	5 bar	420	460	5 bar	400	340
7 bar	460	500	7 bar	500	550	7 bar	650	650
8-16 bar	460	500	8-16 bar	500	550	8-16 bar	700	750

Inlet Pressure	RB 1810		Inlet Pressure	RB 1820		Inlet Pressure	RB 1830	
	Outlet Pressure Setting			Outlet Pressure Setting			Outlet Pressure Setting	
	20 mbar	50 mbar		300 mbar	500 mbar		1000 mbar	2500 mbar
100 mbar	200	160	400 mbar	240	-	1.4 bar	550	-
200 mbar	300	260	500 mbar	340	-	1.8 bar	800	-
400 mbar	420	420	600 mbar	420	240	2 bar	900	-
600 mbar	500	500	700 mbar	500	340	2.2 bar	1000	-
800 mbar	600	600	800 mbar	550	420	2.4 bar	1000	-
1 bar	700	700	1 bar	600	550	2.6 bar	1100	360
1.5 bar	850	850	1.5 bar	850	750	2.8 bar	1100	600
2 bar	1000	1000	2 bar	1000	950	3 bar	1100	800
-3-16 bar	1100	1100	3-16 bar	1100	1100	4-16 bar	1100	1100

In order to limit the noise emission it is recommended not to exceed a gas velocity of 150 m/s at the regulator outlet.

FLOW CAPACITY

For a 0.6 specific gravity gas, the wide-open orifice flow (Q) may be calculated using the following equations:

» Sub-critical flow behaviour: $Q = K_G \sqrt{P_d(P_u - P_d)}$

where $(P_u - P_d) \leq 0.5 P_u$

» Critical flow behaviour: $Q = K_G P_u / 2$

where $(P_u - P_d) > 0.5 P_u$

Wide-open Flow Coefficient K_G

DN	RB 1700	RB 1800
K _G	250	700

The K_G flow coefficient is reduced by 5% when a SSV is built into the regulator.

Standard conditions:

- Absolute pressure of 1.013 bar -
Temperature of 15°C

Correction factor for non-natural gas applications:

The flow rates are indicated for a 0.6 specific gravity gas.

To determine the volumetric flow rate for gases other than natural gas, multiply or calculate the values in the capacity tables using the sizing equations with a correction factor.

The table below lists correction factors for some common gases:

Gas type	Specific gravity	Correction factor
Air	1.00	0.77
Butane	2.01	0.55
Carbon dioxide (dry)	1.52	0.63
Carbon monoxide (dry)	0.97	0.79
Natural gas	0.60	1.00
Nitrogen	0.97	0.79
Propane	1.53	0.63
Propane-Air mix	1.20	0.71

Specific gravity or relative density (air = 1, non-dimensional value)

Use the following formula to calculate the correction factor for gases not listed above. In the formula, d is the specific gravity of the gas.

$$\text{Correction factor} = \sqrt{\frac{0.6}{d}}$$

where:

Q = volumetric flow rate in m³/h at standard conditions

P_u = absolute inlet pressure in bar

P_d = absolute outlet pressure in bar

Overall Dimensions

DN	Actuator	A mm	B mm	C mm	D mm	E mm	F mm	G mm	Weight (kg) with SSV	DN	A1 mm	
RB 1700	Ø 220	130	356	45	220	155	Ø 60	59	10	13	DN 25	184
RB 1800	Ø 220	150	390	60	220	186	Ø 90	85	16	19	DN 40	223
RB 1800	Ø 360	150	374	60	360	180	Ø 120	85	19	22	DN 50	223

Vent and Sensing Lines

- » Regulator sensing line: Rp ¼ with compression fitting for 10 mm pipe
- » Regulator vent line: G¾ optional
- » SSV sensing line:
 - RB 1700: internal
 - RB 1800: Rp ¼ with compression fitting for 10 mm pipe
- » SSV vent line: Rp 1/8

Type Designation

RBE	XX	X	X	X	- DN X	Options
	17					Body 1"
	18					Body 1½"
		1				Low pressure – only on RB 1800
		2				Medium pressure
		3				High pressure
			0			No safety device
				1		Over-pressure shut-off valve
				2		Over-and-under pressure shut-off valve
					M	Monitor version
					R	With relief valve - only by low pressure
					1"	Threaded connection – only on RB 1700
					1½"	Threaded connection – only on RB 1800
					25	Flanged connection – only on RB 1700
					40	Flanged connection – only on RB 1800
					50	Flanged connection – only on RB 1800

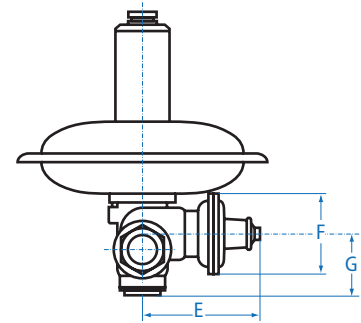
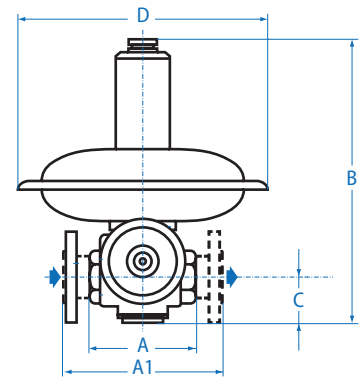

RB 1700 / RB 1800

Information to be specified when ordering:

- » Regulator type code
- » Minimum and maximum inlet pressures
- » Outlet pressure range
- » Outlet pressure setting
- » Connection type
- » Options
 - OPSO setting*
 - UPSO setting*

* (if requested)

Dresser Utility Solutions GmbH

Hardeckstr. 2
76185 Karlsruhe
T: +49 (0)721 / 5981 - 100
info.karlsruhe@dresserutility.com



© 2023 Dresser Utility Solutions GmbH – All rights reserved. Dresser Utility Solutions reserves the right to make changes in specifications and features shown herein, or discontinue the product described at any time without notice or obligation. Contact your Dresser Utility Solutions representative for the most current information. The Dresser Logo and all Trademarks containing the term "Dresser" are the property of Dresser, LLC, a subsidiary of Baker Hughes. Actaris™ is a trademark owned by Itron, Inc. and used under license.