



# ACD G10 and G16

Diaphragm Meters - High Accuracy Commercial Meters

Our new generation Itron Diaphragm G10-G16 meters combine accuracy and long life in a very compact casing. Through our proven know-how in gas measurement, combined with the use of modern engineering and production techniques, Itron has developed this smaller size, highly accurate meter, ensuring reduced shipping costs, and easier handling and simplified installation. Our range of ACD G10-G16 meters are designed for commercial use for gas suppliers and gas utilities worldwide.

## KEY BENEFITS

- » Ready for remote reading and data management
- » Long-term accuracy and reliability
- » Robust, maintenance-free meter
- » Compact design
- » MID approved
- » High resistance to corrosion

## APPLICATION

The ACD diaphragm meters are used for applications requiring high precision and large rangeability at low pressure (below 1 bar gauge).

They are supplied in two versions - a compact and a standard version (single and two pipe). Due to the volumetric principle of the diaphragm meters, its metrology is not influenced by installation conditions.

They are designed for use with natural gas, manufactured gas and other non-corrosive gases. The ACD diaphragm meters are approved for fiscal use.

## OPERATING PRINCIPLE

The movement of the diaphragm is caused by the pressure difference between the inlet and the outlet of the meter. The reciprocal filling is controlled by means of two sliding valves.

This oscillating movement is transformed into a rotational one and is mechanically transmitted to the totalizer through a magnetic coupling or a stuffing box.

## TYPICAL ERROR CURVE

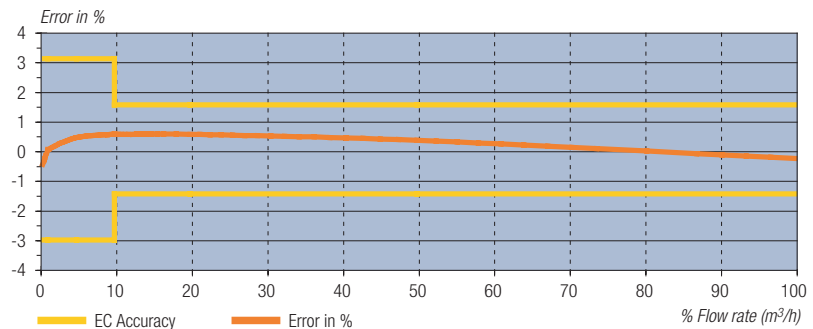

## PRESSURE LOSS CURVE

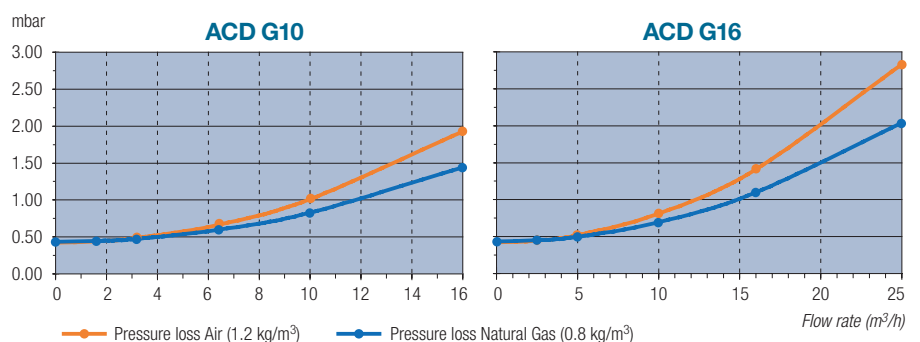

## CONSTRUCTION

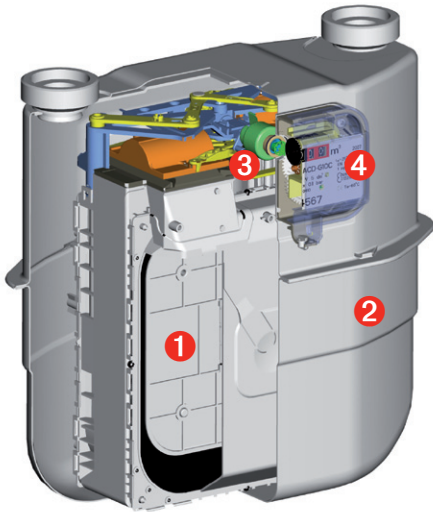

### The ACD G10-G16 meters contain four main parts:

- 1 A measuring unit with:
  - » Four measuring chambers.
  - » Two sliding valves.
  - » An outlet pipe.
- 2 A steel casing fitted with one or two connections
- 3 A magnetic coupling or stuffing box transmits the movement of the measuring unit to the totalizer
- 4 A totalizer is available in different versions depending on the application
  - » "e" series: electronic index for a 2-way wired/wireless M-Bus communication and with optional electronic temperature conversion.
  - » "c" series: mechanical index equipped with a Cyble target for retrofittable AMR communication systems. This Itron standardised meter interface allows the adaptation of different Cyble modules as a communication device.
  - » "o" series: mechanical index available with a permanent magnet in an index drum. Can be refitted with a Low Frequency pulse transmitter (Reed switch).



ACD Measuring Unit

### Technical Specifications

Gas Type	Natural Gas, air, propane, butane, nitrogen and all non-corrosive gases	
Cyclic Volume	5 dm <sup>3</sup>	
Temperature Range	Ambient: -25°C to +55°C Gas: -25°C to +55°C Storage: -40°C to +70°C	
Maximum Operating Pressure	Compact version: 0.5 bar Standard version: 0.5 bar (1 bar optional)	
Measuring Range	G10:	Qmin 0.10 m <sup>3</sup> /h Qmax 16 m <sup>3</sup> /h
	G16:	Qmin 0.16 m <sup>3</sup> /h Qmax 25 m <sup>3</sup> /h
Accuracy	Class 1.5	
Approval	MID (04/22/EC) module B & D	
Metrology	In accordance with the EN1359:1998/A1:2006 and MID Maximum permissible errors are +/-3% from Qmin to 0.1 Qmax and +/-1.5% from 0.1 Qmax to Qmax.	
Starting Flow Rate	Typical value: < 8 dm <sup>3</sup> /h	
Totalizer	IP54 UV resistant cover Fitted with a reflecting disc on the first drum to facilitate periodical checks Customised name plate: bar code, customer serial number or logo	
Magnetic Coupling Stuffing Box	The meter is equipped as standard with a magnetic coupling As an alternative a stuffing box can be also installed	
Connections	Single pipe or 2 pipe connections From DN32 to DN50 depending on the G-size Other connections are available on request	
Backrun Stop	Prevents the meter from running backwards in case of tampering	
RPF (Resistant Power Factor)	According to PRS11 (< 1.2)	
Materials	Casing:	aluminium-coated sheet steel
	Measuring unit body:	polyacetal (POM)
	Diaphragms:	polyester fabric coated with NBR-ECO
	Distribution valves and grid:	phenol resin
Colour	Light grey RAL7035	

### Options

Thermowell	The meters can be fitted with a thermowell to allow electronic temperature compensation. A second thermowell for reference measurements is available on special request
High Temperature Loading (HTL)	The meters can be delivered in a HTL version following EN1359 PNO,1
Pressure Tapping	This device allows the gas pressure to be measured at a reference point.



Thermowell fitted onto an ACD standard

## TOTALIZER FEATURES

With the ECO series, Itron offers a complete portfolio to address today's and future energy resource and environmental challenges.

### "e" series

Supporting the prevailing European Communication

Standards and ensuring interoperability

This smart meter equipped with an electronic index is designed to facilitate integration into wired and wireless fixed networks and has built-in communications capabilities which detects reversed operation, magnetic tampering and backflow.

- » High accuracy error curve correction
- » Optional temperature conversion
- » Built-in 2-way wired/wireless M-Bus communication
- » Safe data transmission with AES
- » Tamper protection and detection

### "c" series

Smart ready, allowing for future AMR capabilities

Itron's latest-generation mechanical index meter comes standard with our Cyble™ target, and can be upgraded in the field to implement AMR and enable remote reading via different communication technologies.

- » Smart reading possible with additional modules
- » Can be retrofitted on site without recalibrating the meter
- » Reliable of an electronic switch (no wear or bouncing)
- » Proven, tested design backed by 20 years' experience
- » Protection against magnetic tampering

### "o" series

Retrofit enabling smart upgrades to existing meter park

- » The "o" series addresses traditional meters with a mechanical index, already installed in the field, to minimize stranded assets when AMR/AMI is required. LF transmitters - via a Reed switch - and a Pulse RF radio module transform pulses into transmittable data.



"o" series Totaliser with LF "cable"

### Building Blocks of Itron's ECO series



Base Meter

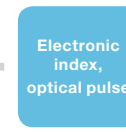

Index



Communication Module

### Totalizer characteristics "e" series

Meter Size	G10 / G16
European Metrological Approval (04/22/EC - Module B)	N° DK-0200-MI002-020
Temperature Range	Temperature (converted): -10°C to +55°C (-25°C to +55°C optional for G10) Storage temperature: -40°C to +70°C (> 55°C for up to 4 hours)
ATEX Approval	II 2G Ex ib IIB T3
Relative Humidity	Maximum 93% non-condensing between -25°C and +55°C
Display	LCD with 9 digits (3 decimals)
M-Bus Interface	300bps / 2400 bps / one bus load, wireless or dongle (up to four bus loads)
Battery	Lithium battery with an average lifetime of min. 15 years under reference conditions
Standards	EN12405-1: 2007-08, Directive 2004/108/EC (EMC) and OIML D11 (EMC), NTA8130-May 2007, DSMR V2.2+ (Netherlands)
Serial Bus	M-Bus slave (wired: EN13757-2/3, wireless: EN13757-4)
Customer Port	IR service interface (EN62056-21)
Mechanical Environment	M1
Electronical Environment	E2



Base Meter

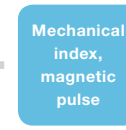

Index



Communication Module

### Totalizer characteristics "c" series

Meter Size	G10 / G16
European Metrological Approval (04/22/EC - Module B)	N° DE-07-MI002-PTB013
Display	Mechanical index with 8 drums (2 decimals)
Transmission Rate	0.1 m³ / rotation
Transmission System	Cyble™ target
Mechanical Environment	M2
Electronical Environment	E2



Base Meter

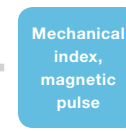

Index



Communication Module

### Totalizer characteristics "o" series

Meter Size	G10 / G16
European Metrological Approval (04/22/EC - Module B)	N° DE-07-MI002-PTB013
Display	Mechanical index with 8 drums (2 decimals)
Pulse Generator	Standard 0.1 m³ / pulse (optional 1 m³ / pulse)
Pulse Transmitter	Retrofittable LF system, 12 Vdc max – 10 mA max. standard 0.1 m³/pulse. Different versions: with 1m cable, terminal block or binder plug (Double LF pulse transmitter)
Mechanical Environment	M2
Electronical Environment	E2

## Dimensions and Weight

Model	G Size	Qmax m <sup>3</sup> /h	Qmin m <sup>3</sup> /h	Cyclic Volume dm <sup>3</sup>	DN mm	Threads Standard	Pmax bar	Pmax HTL bar	Pressure Loss (Air) mbar	A mm	B mm	C mm	D mm	E mm		Weight kg	
														"e" series	"c & o" series	"e" series	"c & o" series

### ACD Compact: 2 pipe version

1	G10	16	0.10	5	32	G1¼" A ISO228-1	0.5	0.1	1.9	250	310	71	325	204	189	4.4	4
2	G10	16	0.10	5	32	MFIT001	0.5	0.1	1.9	250	310	71	325	204	189	4.4	4
3	G10	16	0.10	5	40	G2" A ISO228-1	0.5	0.1	1.9	250	310	71	325	204	189	4.4	4
4	G16	25	0.16	5	40	G2" A ISO228-1	0.5	0.1	2.9	250	310	71	325	204	189	4.4	4

### ACD Standard: 2 pipe version

10	G10	16	0.10	5	32	G1¼"A ISO228-1	0.5	0.1	1.9	280	328	85	382	206	191	5.3	4.9
11	G10	16	0.10	5	40	G2"A ISO228-1	0.5	0.1	1.6	280	324	85	382	206	191	5.3	4.9
12	G10	16	0.10	5	40	G2"A ISO228-1	0.5	0.1	1.6	290	349	85	382	206	191	5.3	4.9
13	G10	16	0.10	5	40	G2"A ISO228-1	0.5	0.1	1.6	300	353	85	382	206	191	5.3	4.9
14	G16	25	0.16	5	32	G1¼"A ISO228-1	0.5	0.1	2.9	280	328	85	382	206	191	5.3	4.9
15	G16	25	0.16	5	40	G2"A ISO228-1	0.5	0.1	2.7	280	324	85	382	206	191	5.3	4.9
16	G16	25	0.16	5	40	G1½" BS Withworth	0.5	0.1	2.7	280	328	85	382	206	191	5.3	4.9
17	G16	25	0.16	5	40	G2"A ISO228-1	0.5	0.1	2.7	300	353	85	382	206	191	5.3	4.9
18	G16	25	0.16	5	50	MFIT001	0.5	0.1	2.7	280	327	85	382	206	191	5.3	4.9
19	G16	25	0.16	5	50	Flange ISO PN10	0.5	0.1	2.7	280	417	123	396	206	191	9.0	8.6
20	G16	25	0.16	5	40	2" BS746	0.5	0.1	2.7	280	347	85	382	206	191	5.3	4.9

### ACD Standard: Single pipe version

30	G10	16	0.10	5	40	G2¾" ISO228-1	0.5	0.1	1.9	-	370	85	382	206	191	5.8	5.4
31	G16	25	0.16	5	40	G2¾" ISO228-1	0.5	0.1	2.9	-	370	85	382	206	191	5.8	5.4

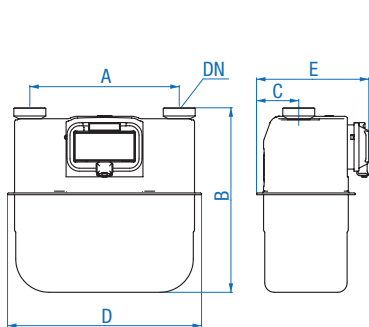

ACD Compact: Two Pipe version

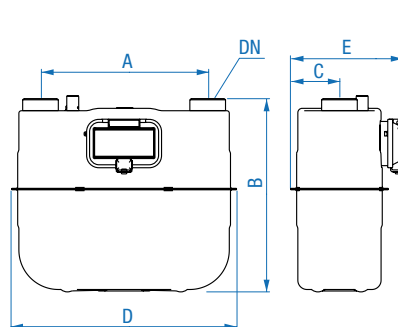

ACD Standard: Two Pipe version

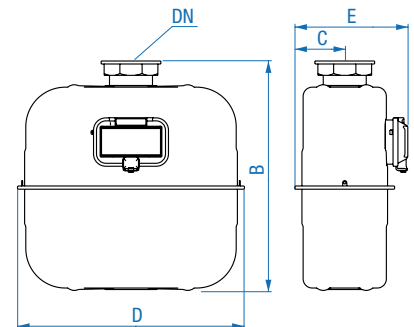

ACD Standard: Single Pipe version



Our company is the world's leading provider of smart metering, data collection and utility software systems, with over 8,000 utilities worldwide relying on our technology to optimize the delivery and use of energy and water.

To realize your smarter energy and water future, start here: [www.itron.com](http://www.itron.com)

For more information, contact your local sales representative or agency:

#### ITRON GmbH

Hardeckstraße 2  
D-76185 Karlsruhe  
Germany

**Phone:** +49-721 5981 0

**Fax:** +49-721 5981 189