

## OPW 5000 Series Bus/Heavy-Duty Truck Nozzles

OPW 5000 Series nozzles are designed for extremely high-flow public and private CNG fueling systems. Applications include quick-fill, self-service fueling of transit buses and large trucks. All OPW NGV fueling nozzles are designed and built to exacting engineering specifications for fueling safety and efficiency.

### Ordering Specifications

Product #	Inlet Thread Size	Service Pressure
CT5000S (directed vent)	SAE - 10, 7/8 - 14 UNF	3625 psi (250 bar)
Connects to CL50 Series heavy-duty receptacles		

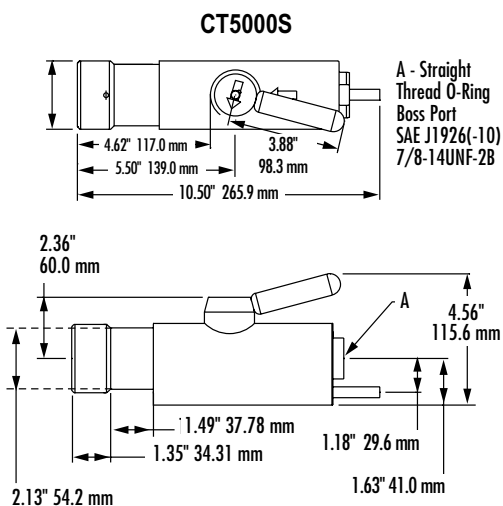

### Materials

- Body:** Brass
- Jaws:** Stainless steel
- Internal Components:** Stainless steel
- Seals:** Specially formulated polymers and elastomers specific to high-pressure NGV applications.

CT5000S  
Hose Connection  
End

CT5000S  
Coupling End



### Features

- User-Friendly Single-Action Operation** - entire fueling operation is initiated by simply engaging nozzle and receptacle with a single 180° rotation of the handle. This automatically secures the nozzle jaws onto the receptacle and activates a system of three internal valves that regulate fueling. The nozzle will not dispense gas until securely engaged onto an appropriate receptacle. When fueling is completed, rotation of the handle to the disconnect position automatically stops the flow of gas into the nozzle, vents the trapped gas and releases the nozzle from the receptacle. The 5000 Series nozzles connect directly to the hose, eliminating the need for a three-way valve. They are designed for public or private self-service applications, eliminating the need for a trained attendant.
- High-Flow/Fast-Fill Capability** - to provide quick fueling of large storage vehicles. Internal seals are specially designed to meet the demands of fast-fill NGV fueling.
- Directed Vent** - directs the gas vented at disconnect and directs it out of the nozzle via a 3/8" stainless steel tubing connection, which can be piped to a remote venting location or back to the upstream side of the compressor. Directing the vent gas is environmentally desirable and will provide an added measure of safety by minimizing the amount of gas present at the filling site. It also reduces vent noise and escaped gas smell.
- Jaw-Lock Technology** - designed specifically for the frequent coupling and uncoupling of the high-pressure gas connections of NGV fueling. Forces at the contact point are distributed over the entire surface area of the receptacle.
- Ergonomic Design** - one simple and convenient motion ensures connection and dispensing by all users. Insulated jacket provides thermal protection for operator's hand.
- Durable Construction** - brass and stainless steel construction provides excellent corrosion resistance in the harsh refueling environment.
- Tamper Resistant** - specially designed cam system actuates the front and rear valve module. Any tampering with the valve will result in an immediate shut-off of the dispensing process.
- Individually Leak Tested and Inspected with Traceable Serial Numbers**

### Specifications:

- Min. Flow Rate: 5000 SCFM @ 3000 psid
- Temperature Range: -40° F to 185° F (-40° C to 85° C)
- Weight: 8.77 lbs. (3.98 kg)
- Cv: 2.75
- MAWP Pressure: 4532 psi (312.5 Bar)