

PROTEGO® Detonation Flame Arresters



Volume 4

Volume 4



for safety and environment

Detonation Flame Arrester

Function and description

The function of flame arresters in the various combustion processes and applications is discussed in „Technical Fundamentals“ (→ Vol. 1). In this chapter, PROTEGO®'s product line of **detonation arresters** for **stable** and **unstable detonations** is presented.

PROTEGO® detonation flame arresters are highly developed safety devices that are used in pipe systems in which detonations can occur. They reliably suppress the effect of a detonation, extinguish the flame, and protect non-explosionproof components and vessels.

The main component generally is the original PROTEGO® flame arrester unit (1), which takes the energy from the detonation and extinguish the flame in narrow gaps. The PROTEGO® flame arrester unit consists of several FLAMEFILTER® discs (2) and spacers, firmly held in the FLAMEFILTER® cage (3). The number of FLAMEFILTER® discs and their gap size depend on the devices intended use and on process parameters such as temperature, pressure, vapour group of the handled gases.

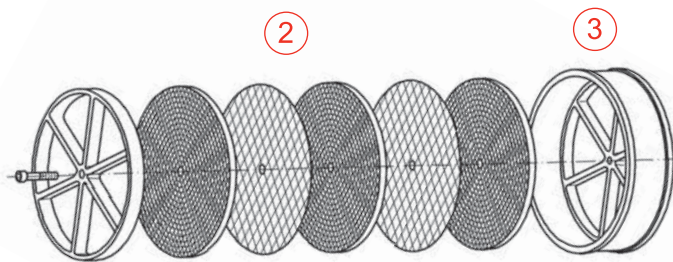

① PROTEGO® flame arrester unit

All dry detonation flame arrester types have a modular design. For larger nominal diameters, energy is withdrawn from the detonation shock wave upon entering the patented shock absorber, the SWGTE (Shock Wave Guide Tube Effect), and other innovative technical solutions, before the detonation reaches the FLAMEFILTER®.

Dry PROTEGO® detonation flame arresters are also tested and safe with respect to deflagrations. Equipped with an additional temperature sensor, they are also protected from short-time stabilized burning on the FLAMEFILTER®.

In close collaboration with scientific institutions, PROTEGO® has developed safety devices that can be used in any area subject to an explosion hazard and protects against stable and unstable detonations, unidirectional or bidirectional. Corresponding statements of conformity (CE, FM, etc.) have been awarded based on type tests according to ATEX, PED, and other international standards.

A wide range of types, designs, nominal diameters and materials are available. In addition, we are able to develop tailor made solutions at our worldwide unique testing facility.

Special features and advantages

The most important distinctive features are the selection criteria: **Stable or unstable** detonations, **dry detonation arresters** for installation in gas- or vapour-conducting pipes, or **liquid detonation arresters**, i.e. flame arresters with a liquid barrier for pipes in which liquids are transported. For the parameters of pressure and temperature, **special operating conditions** beyond standard values may have to be considered.

It is important to categorize the products or the components of the mixture into **explosion groups** according to their MESH to select the suitable flame arrester from the various designs for all the explosion groups.

The designs differ according to their **concentric, eccentric, and 90-degree design**.

The respective system specification must be considered when choosing the required **nominal diameters and types of connection**.

A **heating jacket** may be necessary, but not every device can be provided with a heating jacket.

There are designs for **critical media**, special **product properties** (such as viscosity, density, crystallization, and polymerization), and for **unidirectional or bidirectional protection**.

Preferred applications

Protection of

- Piping systems
- Tanks and vessels in chemical, petrochemical, and pharmaceutical processing plants
- Loading systems
- Gas collection systems
- Exhaust gas combustion systems
- Flare systems
- Landfills and biogas systems
- Waste-water treatment plants

Installation and maintenance

PROTEGO® detonation flame arresters are also tested and protect against deflagrations so that they can be used at any distance from a potential ignition source. However, they are preferably installed as close as possible to the part of the system to be protected. No pipes with a nominal diameter greater than the nominal diameter of the devices shall be connected to detonation arresters.

Given the modular design of the PROTEGO® flame arrester unit, any type of detonation flame arrester is extremely easy to service. For servicing reasons, the location of the flame arrester must be planned to be very accessible; a hoist must be provided if the flame arrester is heavy. Servicing is easy for trained personnel.

PROTEGO® detonation flame arresters are used in areas subject to explosion hazards. Select devices that match the intended use. The manufacturer's certificate of conformity provides the boundary conditions for which the device is suitable. The user has to document proper use in accordance with applicable safety guidelines or standards.

Selection

The possible types are pre-selected from the product line based on the most important process data:

- **Stable** detonations or **unstable detonations**
- Lines that conduct **dry gas/vapours** or **liquids**
- Standard or **non-standard operating conditions** (pressure and temperature)
- **Explosion group** of the transported mixture

Finally, the following criteria are reviewed and selected:

- Approvals according to ATEX, FM, USCG, CSA, GOST-R, GL, IMO, etc.
- Concentric, excentric, or 90-degree design
- Nominal diameter and type of connection
- Heating jacket or custom-supplied electrical heat tracing
- Critical media
- Unidirectional or bidirectional

If no suitable device can be found, please contact us. Special designs and approvals are available.

Based on this initial selection, the additional details such as materials, coatings, etc. can be requested or defined in the type sheet.

Sizing

The nominal diameter of the device is determined or checked in the p/V flow chart. A safety margin must be provided when the processed fluid is highly contaminated.

- Given:** Volume flow m^3/h or CFH
- Given:** Max. all. pressure drop Δp mbar or inch W.C.
- Desired:** Nominal diameter of the detonation flame arrester DN

Procedure: Intersection of the lines with the volume flow and maximum allowable pressure drop lies above or on the desired nominal diameter curve

or

- Given:** Volume flow m^3/h or CFH
- Given:** Nominal diameter of pipe DN
- Desired:** Pressure drop Δp mbar or inch W.C.

Procedure: Intersection of the lines with the volume flow and nominal diameter curve, horizontal straight line leads to the desired pressure drop

Instructions on how to calculate the volumetric flow or influence of density are found in Vol. 1 „Technical Fundamentals“.



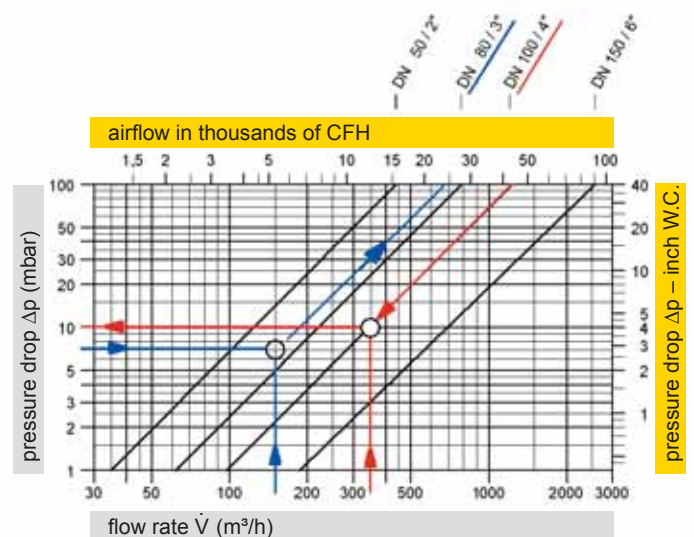



After all steps are complete, the device can be completely specified and requested or ordered.











for safety and environment

Selection Guide

PROTEGO® Detonation Flame Arrester

	Type	Size	Design cc = concentric ec = eccentric	Explosion Group		Approvals	○ = dry type x = liquid type	○ = for non-standard operating parameter	○ = for critical medium (polymerisation, corrosion, crystallisation)	○ = Heating jacket, Heating coil	○ = unidirectional, x = bidirectional	Page
				ATEX	NEC							
for stable detonation												
	DA-G	G ½" - G 2"	straight through, cc	IIA, IIB3, IIC	D, C, B	ATEX	○	○			x	113 - 121
	DA-E	25-300 1" - 12"	straight through, ec	IIA, IIB3	D, C	ATEX	○	○			x	122 - 124
	DA-SB	50-600 2" - 24"	straight through, cc	IIA, IIB3, IIC	D, C, B	ATEX	○	○		○	x	126 - 131
	DR/ES	G ¼" - G ¾"	90-degree	IIA, IIB3, IIC	D, C, B	ATEX	○	○			○	132 - 134
	DR/ES	25-200 1" - 8"	90-degree	IIA, IIB3	D, C	ATEX	○/x	○		○	○	136 - 140
	DR/ES-V	40-200 1 ½" - 8"	90-degree	IIA, IIB3	D, C	ATEX	○	○		○	○	142 - 145

	Type	Size	Design cc = concentric ec = eccentric	Explosion Group		Approvals	○ = dry type x = liquid type	○ = for non-standartd operating parameter	○ = for critical medium (polymerisation, corrosion, crystallisation)	○ = Heating jacket, Heating coil	○ = unidirectional, x = bidirectional	Page
				ATEX	NEC							
for stable detonation / for liquid detonation												
	LDA-W	25-300 1" - 12"	straight through	IIA, IIB3	D, C	ATEX	x		○		○	146 - 147
	LDA-WF(W)	25-250 1" - 10"	straight through	IIA, IIB3	D, C	ATEX	x		○		○	148 - 149
	LDA	25-250 1" - 10"	vertical	IIA, IIB3	D, C	ATEX	x				○	150 - 151
	LDA-F	25-250 1" - 10"	vertical	IIA, IIB3	D, C	ATEX	x				○	152 - 153
	EF/V	25-250 1" - 10"	vertical	IIB3	C	ATEX	x				○	154 - 155
	TS/P TS/E TS/W			IIA, IIB3, IIC	D, C, B	ATEX	x		○		○	156 - 157
for unstable detonation												
	DA-UB	50-600 2" - 24"	straight through, cc	IIA, IIB3	D, C	ATEX	○	○		○	x	158 - 161
	DA-CG	50-600 2" - 24"	straight through, cc	IIA, IIB3	D, C	USCG	○	○		○	x	162 - 165
	DR/EU	25-150 1" - 6"	90-degree	IIA, IIB2, IIB3	D, C, C	ATEX	○	○		○	○	166 - 168

Larger sizes upon request



for safety and environment

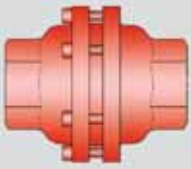

In-Line Detonation Flame Arrester

for stable detonations and deflagrations in a straight through design,
bidirectional

PROTEGO® DA-G

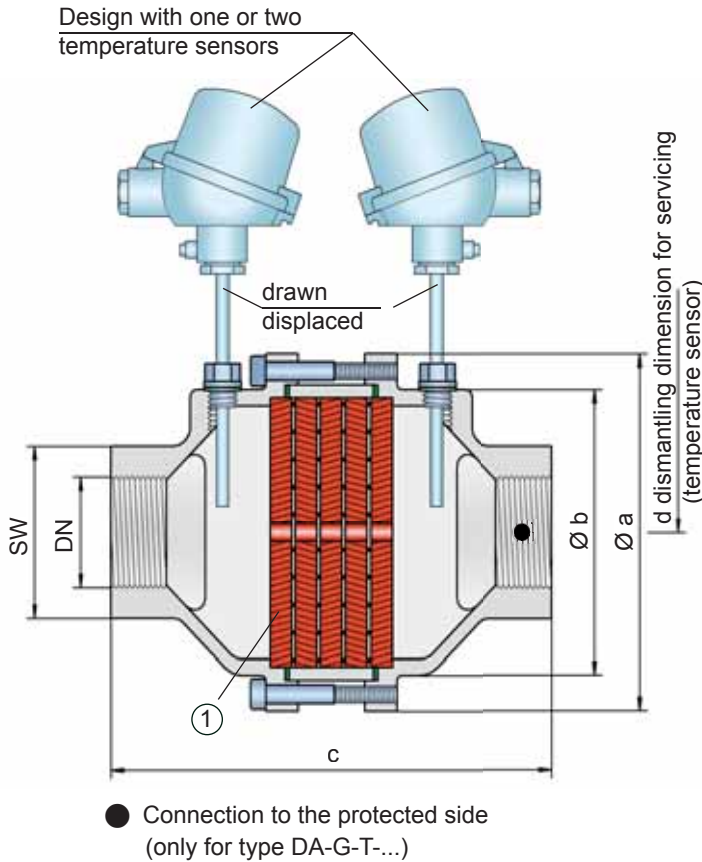

that can be used for all explosion groups, IIA, IIB3 and IIC (NEC Group D, C MESH ≥ 0.65 mm and B). The standard design can be used up to an operating temperature of $+60^{\circ}\text{C}$ / 140°F and an absolute operating pressure up to 1.1 bar / 15.9 psi. Devices with special approvals can be obtained for higher pressures (see table 4) and higher temperatures upon request.

The device is bidirectional and equipped with a threaded connection. The thread can be executed to international standards. The detonation arrester can be used at any location in the pipe, independently from the location of the ignition source.

Type-approved according to ATEX Directive 94/9/EC and EN ISO 16852 as well as other international standards.

Special Features and Advantages

- bidirectional
- modular design
- the individual FLAMEFILTER® discs can be quickly removed and installed
- the individual FLAMEFILTER® discs are easy to service and replace
- different application possibilities
- possible installation of temperature sensors
- cost efficient spare parts

Design Types and Specifications

There are three different designs available:

Basic design of the DA-G in-line detonation flame arrester, size $\frac{1}{2}$ " to 2" **DA-G-** -

In-line detonation flame arrester with integrated temperature sensor* as additional protection against short burning from one side, size $\frac{1}{2}$ " to 2" **DA-G-** T

In-line detonation flame arrester with two integrated temperature sensors* as additional protection against short time burning from both sides, size $\frac{1}{2}$ " to 2" **DA-G-** TB

*Resistance thermometer for device group II, category (1) 2 (GII cat. (1) 2)

Flange connection available upon request

Function and Description

The PROTEGO® DA-G series is a compact in-line detonation flame arrester for installation in pipes with diameters up to 2", and is used, for example, in industrial applications such as gas analyzing lines.

Once a detonation enters the flame arrester, energy is absorbed from the shock wave, and the flame is extinguished in the narrow gaps of the FLAMEFILTER® (1).

The PROTEGO® flame arrester unit consists of several FLAMEFILTER® discs firmly held in a housing. The gap size and number of FLAMEFILTER® discs are determined by the operating data and parameters of the mixture flowing in the line (explosion group, pressure, temperature).

To provide an optimum result between the housing size, number of FLAMEFILTER® discs and their gap size, a device was developed

Table 1: Dimensions

Dimensions in mm / inches, SW = width across flats

To select the nominal size (DN), please use the flow capacity charts on the following pages

DN	G 1/2"	G 3/4"	G 1"	G 1 1/4"	G 1 1/2"	G 2"
a	80 / 3.15	80 / 3.15	100 / 3.94	100 / 3.94	155 / 6.10	155 / 6.10
b	55 / 2.17	55 / 2.17	76 / 2.99	76 / 2.99	124 / 4.88	124 / 4.88
c (IIA)	112 / 4.41	112 / 4.41	122 / 4.80	122 / 4.80	205 / 8.07	205 / 8.07
c (IIB3 and IIC)	135 / 5.31	135 / 5.31	145 / 5.71	145 / 5.71	205 / 8.07	205 / 8.07
d	—	—	—	—	400 / 15.75	400 / 15.75
SW	32 / 1.26	32 / 1.26	50 / 1.97	50 / 1.97	75 / 2.95	75 / 2.95

Table 2: Selection of the explosion group

MESG	Expl. Gr. (IEC/CEN)	Gas Group (NEC)	Special approvals upon request
> 0,90 mm	IIA	D	
≥ 0,65 mm	IIB3	C	
< 0,50 mm	IIC	B	

Table 3: Selection of max. operating pressure

DN		G 1/2"	G 3/4"	G 1"	G 1 1/4"	G 1 1/2"	G 2"	P _{max} = maximum allowable operating pressure in bar / psi (absolute), higher operating pressure upon request
Expl. Gr.	IIA	P _{max}	1.2/17.4	1.2/17.4	1.1/15.9	1.1/15.9	1.1/15.9	
	IIB3	P _{max}	1.1/15.9	1.1/15.9	1.1/15.9	1.1/15.9	1.4/20.3	
	IIC	P _{max}	1.1/15.9	1.1/15.9	1.1/15.9	1.1/15.9	1.6/23.2	

Table 4: Specification of max. operating temperature

≤ 60°C / 140°F	higher operating temperatures upon request
T60	T _{maximum allowable operating temperature in °C}

Table 5: Material selection for housing

Design	A	B	C	* the FLAMEFILTER® are also available in the materials Tantalum, Inconel, Copper, etc. when the listed housing materials are used.
Housing	Steel	Stainless Steel	Hastelloy	
Gasket	PTFE	PTFE	PTFE	
FLAMEFILTER® *	Stainless Steel	Stainless Steel	Hastelloy	

Special materials upon request

Table 6: Type of connection

Pipe thread DIN ISO 228-1	DIN	other types of thread upon request
---------------------------	-----	------------------------------------



for safety and environment

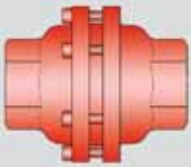

In-Line Detonation Flame Arrester

Flow Capacity Charts

PROTEGO® DA-G

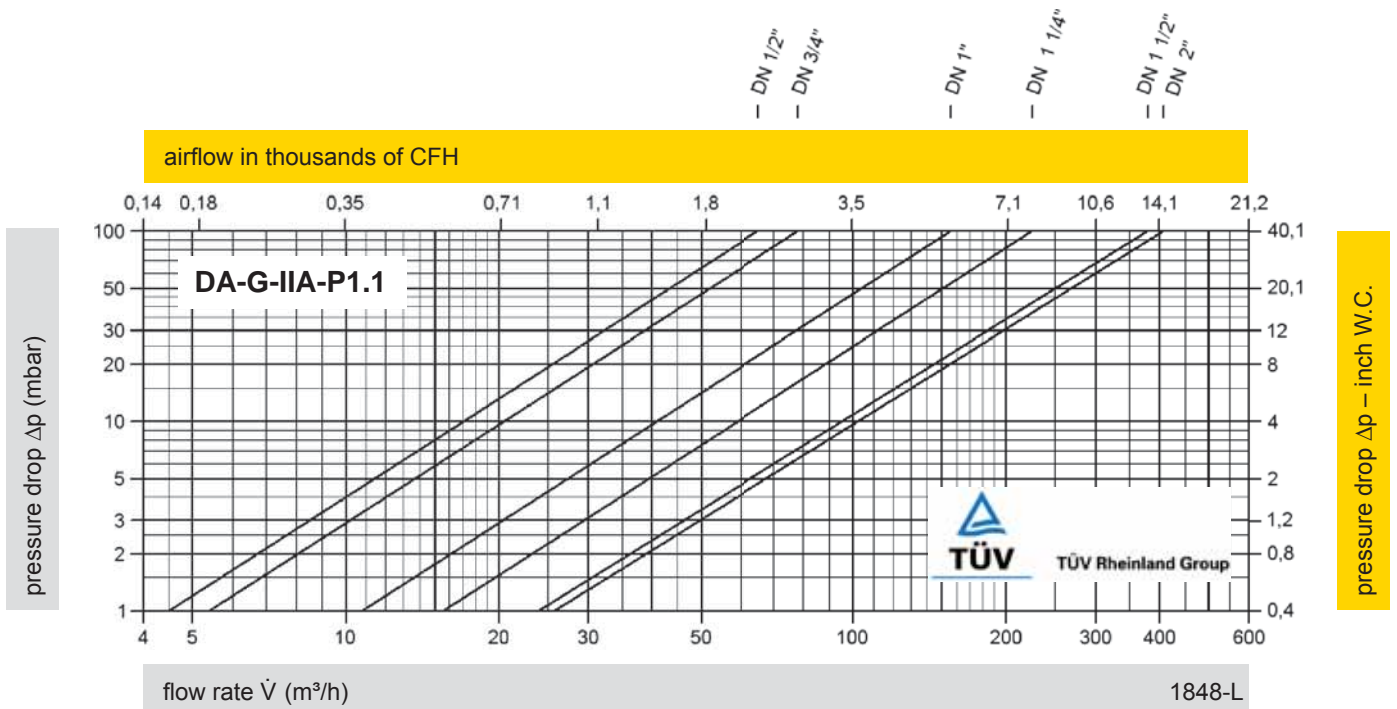

* P1.4

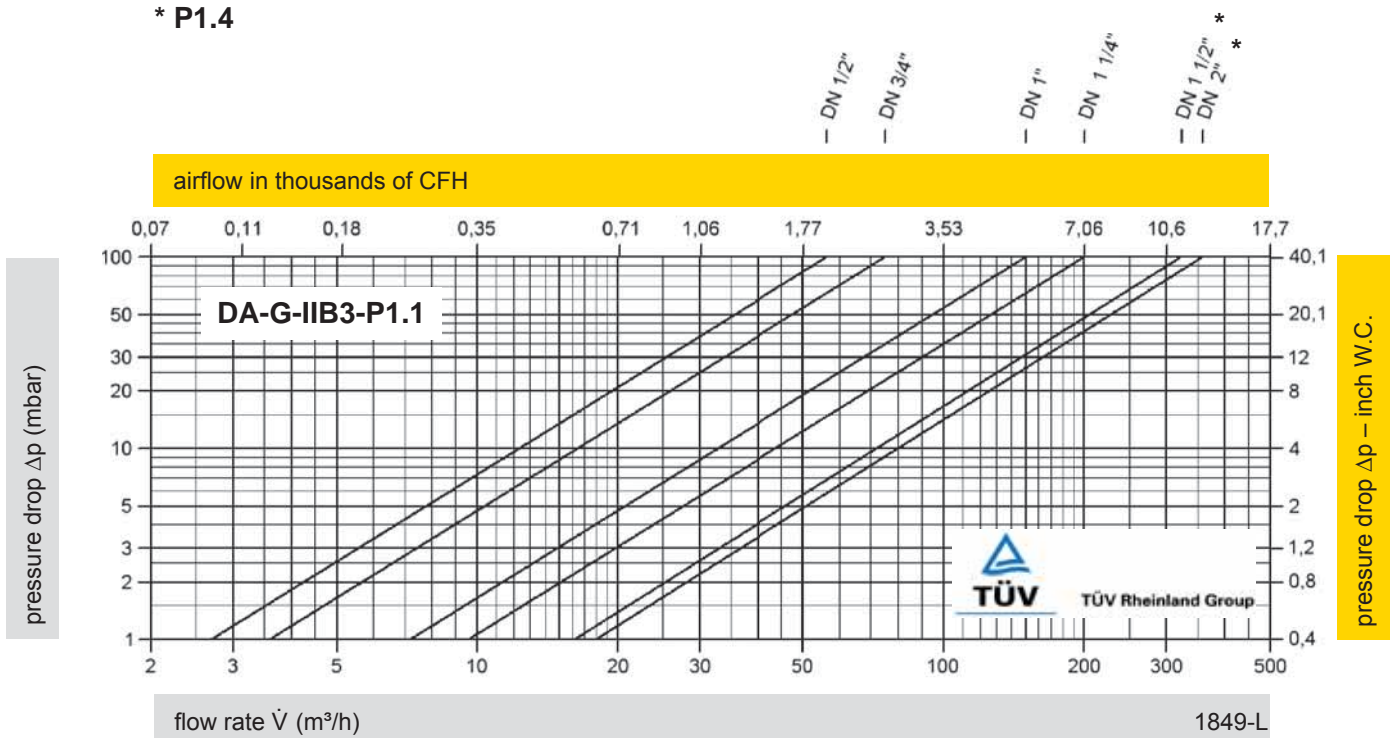

The flow capacity charts have been determined with a calibrated and TÜV certified flow capacity test rig. Volume flow \dot{V} in (m³/h) and CFH refer to the standard reference conditions of air ISO 6358 (20°C, 1bar). Conversion to other densities and temperatures refer to Vol. 1: "Technical Fundamentals".

* P1.6

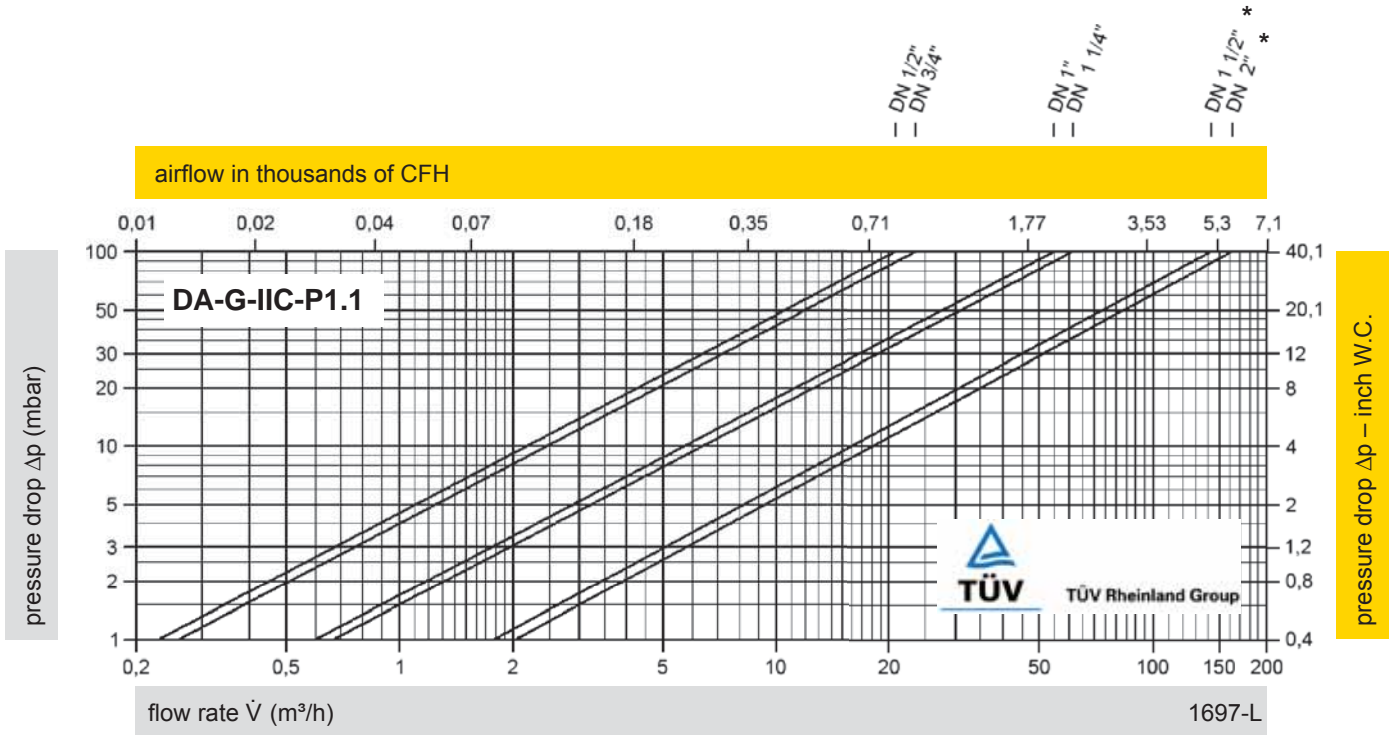



Eccentric In-Line Detonation Flame Arrester

for stable detonations and deflagrations in a straight through design,
bidirectional

PROTEGO® DA-E

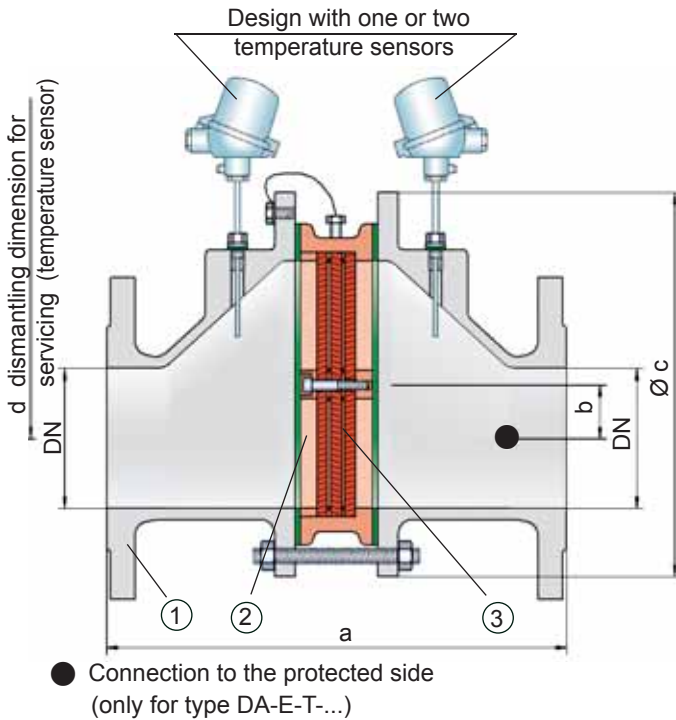

Function and Description

The PROTEGO® DA-E series of detonation arresters is distinguished by its eccentric housing shape. When condensate accumulates within the PROTEGO® flame arrester unit, the design enables the liquid to drain without collecting large amounts in the housing. The eccentric design of the device has decisive advantages in comparison to the classic flame arresters when pipes are installed close to ground level.

The detonation arrester is symmetrical and offers bidirectional flame arresting. The arrester essentially consists of two housing parts (1) and the PROTEGO® flame arrester unit (2) in the center. The PROTEGO® flame arrester unit consists of several FLAMEFILTER® discs (3) and spacers firmly held in a FLAMEFILTER® cage. The number of FLAMEFILTER® discs and their gap size depends on the arrester's conditions of use. By indicating the operating parameters such as temperature, pressure and explosion group and the composition of the fluid, the optimum detonation arrester

can be selected. The PROTEGO® DA-E series of flame arresters is available for explosion groups IIA to IIB3 (NEC Group D to C MESH ≥ 0.65 mm).

The standard design can be used up to an operating temperature of $+60^{\circ}\text{C}$ / 140°F and an absolute operating pressure acc. to table 3. Devices with special approval can be obtained for higher pressures and higher temperatures upon request.

Type-approved according to ATEX Directive 94/9/EC and EN ISO 16852 as well as other international standards.

Special Features and Advantages

- eccentric design prevents the collection of condensate
- the modular design enables each individual FLAMEFILTER® discs to be replaced
- easy maintenance with quick removal and installation of FLAMEFILTER® discs
- eccentric design allows installation in close to ground level
- bidirectional operation as well as any flow direction and installation position
- protects from deflagration and stable detonation
- installation of temperature sensors possible
- cost efficient spare parts

Design Types and Specifications

There are three different designs available:

Basic design of the detonation arrester **DA-E-**

In-line detonation flame arrester with integrated temperature sensor* as additional protection against short time burning of one side **DA-E-** T

Detonation arrester with two integrated temperature sensors* as additional protection against short time burning from both sides **DA-E-** TB

Additional special arresters upon request

*Resistance thermometer for device group II, category (1) 2 (GII cat. (1) 2)

Table 1: Dimensions

Dimensions in mm / inches

To select the nominal size (DN), please use the flow capacity charts on the following pages

DN		25 1"	32 1 ¼"	40 1 ½"	50 2"	65 2 ½"	80 3"	100 4"	125 5"	150 6"	200 8"	250 10"	300 12"	
Expl. Gr.	IIA	a	304/315* / 11.97/12.4*	304/315* / 11.97/12.4*	320/ 12.60	325/ 12.80	370/ 14.57	375/ 14.76	380/ 14.96	481/ 18.94	487/ 19.17	510/ 20.08	540/ 21.26	560/ 22.05
	IIB3	a	304/ 11.97	304/ 11.97	357/ 14.06	361/ 14.21	408/ 16.06	412/ 16.22	428/ 16.85	493/ 19.41	499/ 19.65	522/ 20.55	552/ 21.73	572/ 22.52
		b	29/ 1.14	29/ 1.14	29/ 1.14	29/ 1.14	38/ 1.50	38/ 1.50	39/ 1.53	65/ 2.56	65/ 2.56	55/ 2.17	58/ 2.28	60/ 2.36
		c	185/ 7.28	185/ 7.28	210/ 8.27	210/ 8.27	250/ 9.84	250/ 9.84	275/ 10.83	385/ 15.16	385/ 15.16	450/ 17.72	500/ 19.69	575/ 22.64
		d	400/ 15.75	400/ 15.75	410/ 16.14	410/ 16.14	440/ 17.32	440/ 17.32	460/ 18.11	520/ 20.47	520/ 20.47	540/ 21.26	570/ 22.44	600/ 23.62

* for IIA-P2.0

Table 2: Selection of the explosion group

MESG	Expl. Gr. (IEC/CEN)	Gas Group (NEC)	Special approvals upon request
> 0,90 mm	IIA	D	
≥ 0,65 mm	IIB3	C	

Table 3: Selection of max. operating pressure

DN		25 1"	32 1 ¼"	40 1 ½"	50 2"	65 2 ½"	80 3"	100 4"	125 5"	150 6"	200 8"	250 10"	300 12"
Expl. Gr.	IIA	P _{max}	2.0 / 29.0	2.0 / 29.0	1.2 / 17.4	1.2 / 17.4	1.2 / 17.4	1.2 / 17.4	1.2 / 17.4	1.2 / 17.4	1.2 / 17.4	1.2 / 17.4	1.2 / 17.4
	IIB3	P _{max}	1.1 / 15.9	1.1 / 15.9	1.2 / 17.4	1.2 / 17.4	1.2 / 17.4	1.2 / 17.4	1.2 / 17.4	1.2 / 17.4	1.2 / 17.4	1.2 / 17.4	1.2 / 17.4

P_{max} = maximum allowable operating pressure in bar / psi (absolute), higher operating pressure upon request

Table 4: Specification of max. operating temperature

≤ 60°C / 140°F	higher operating temperatures upon request
T60	T _{maximum allowable operating temperature in °C}

Table 5: Material selection for housing

Design	B	C	D	The housing is also available in carbon steel with an ECTFE coating.
Housing	Steel	Stainless Steel	Hastelloy	
Gasket	PTFE	PTFE	PTFE	
Flame arrester unit	A, C	C	D	

Special materials upon request

Table 6: Material combinations of the flame arrester unit

Design	A	C	D	*the FLAMEFILTER® are also available in the materials Tantalum, Inconel, Copper, etc. when the listed housing and cage materials are used.
FLAMEFILTER® cage	Steel	Stainless Steel	Hastelloy	
FLAMEFILTER® *	Stainless Steel	Stainless Steel	Hastelloy	
Spacer	Stainless Steel	Stainless Steel	Hastelloy	

Special materials upon request

Table 7: Flange connection type

EN 1092-1, Form B1 or DIN 2501, Form C, PN 16; from DN 200 PN 10	EN or DIN	other types upon request
ANSI 150 lbs RFSF	ANSI	



for safety and environment



Eccentric In-Line Detonation Flame Arrester

Flow Capacity Charts

PROTEGO® DA-E

* P1.3

DN 25 / 1" *
DN 32 / 1 1/4" *
DN 40 / 1 1/2"
DN 50 / 2"
DN 65 / 2 1/2"
DN 80 / 3"
DN 100 / 4"
DN 125 / 5"
DN 150 / 6"
DN 200 / 8"
DN 250 / 10"
DN 300 / 12"

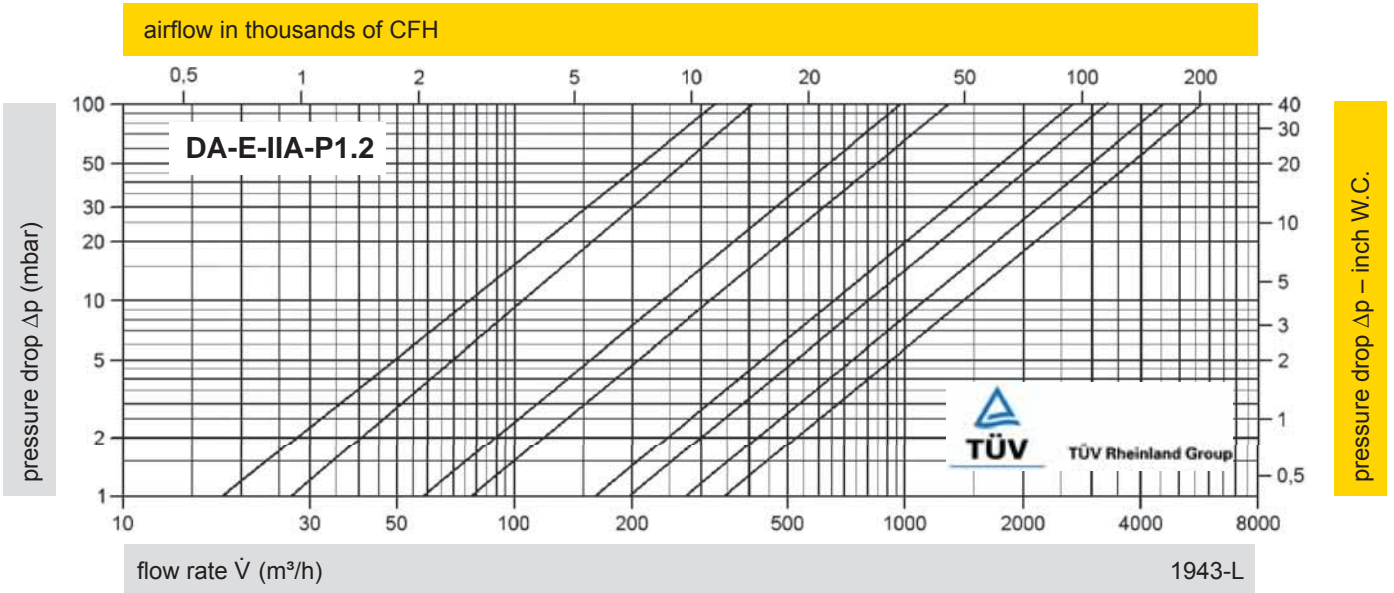

* P1.1

DN 25 / 1" *
DN 32 / 1 1/4" *
DN 40 / 1 1/2"
DN 50 / 2"
DN 65 / 2 1/2"
DN 80 / 3"
DN 100 / 4"
DN 125 / 5"
DN 150 / 6"
DN 200 / 8"
DN 250 / 10"
DN 300 / 12"

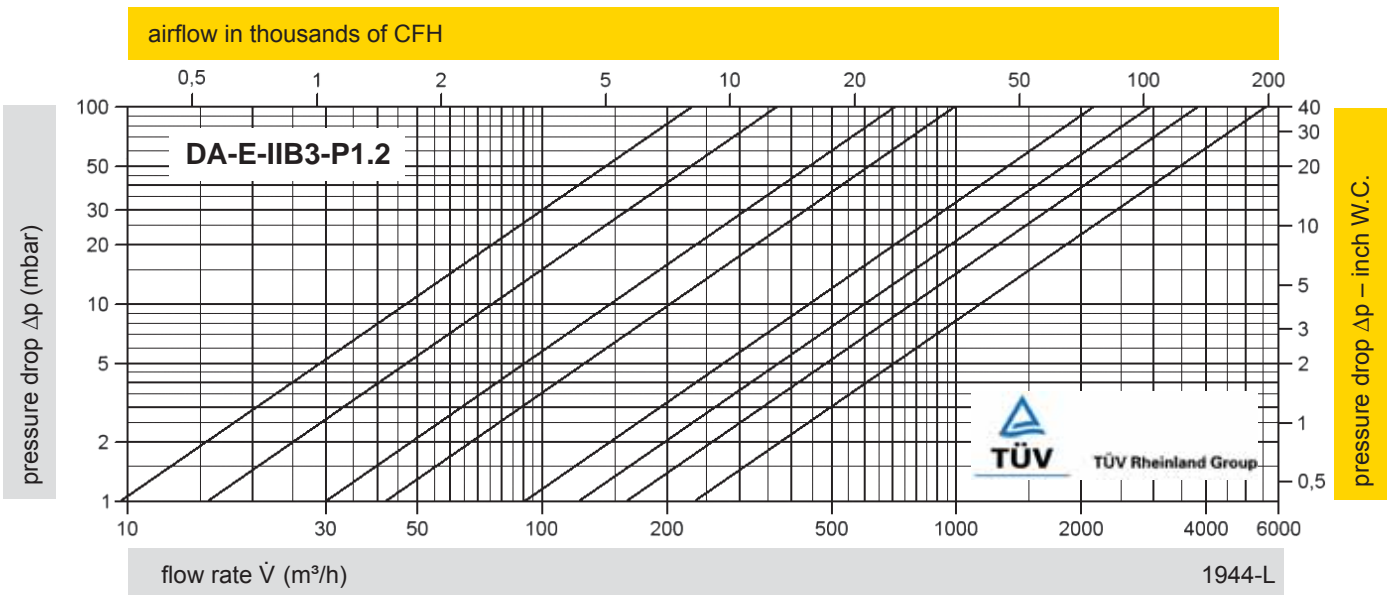

The flow capacity charts have been determined with a calibrated and TÜV certified flow capacity test rig. Volume flow \dot{V} in (m³/h) and CFH refer to the standard reference conditions of air ISO 6358 (20°C, 1bar). Conversion to other densities and temperatures refer to Vol. 1: "Technical Fundamentals".

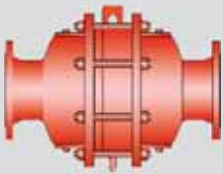

In-Line Detonation Flame Arrester

for stable detonations and deflagrations in a straight through design with shock tube, bidirectional

PROTEGO® DA-SB

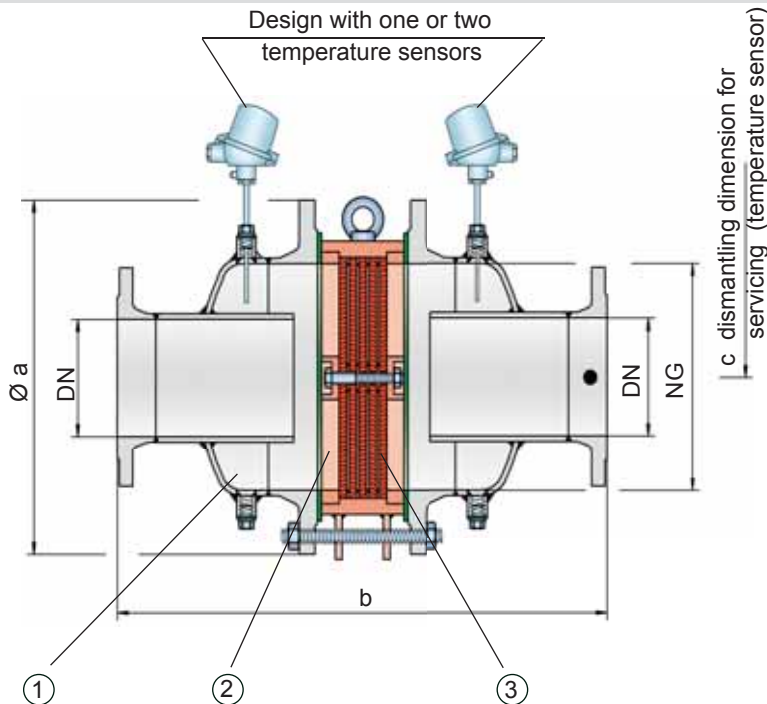

● Connection to the protected side (only for type DA-SB-T-...)

Function and Description

The in-line detonation flame arresters type PROTEGO® DA-SB are the newest generation of flame arresters. On the basis of fluid dynamic, explosion dynamics calculation and decades of experience from field tests, a product line was developed that offers minimum pressure loss and maximum safety. The flame arrester uses the *Shock Wave Guide Tube Effect (SWGTE)* to separate the flame front and shock wave. The result is an in-line detonation arrester without a classic shock absorber; in addition the use of FLAMEFILTER® discs is minimized.

The devices are symmetrical and offer bidirectional flame arresting for deflagrations and stable detonations. The arrester essentially consists of two housing parts with an integrated shock tube (1) and the PROTEGO® flame arrester unit (2) in the center. The PROTEGO® flame arrester unit is modular and consists of several FLAMEFILTER® discs (3) and spacers firmly held in a FLAMEFILTER® cage. The number of FLAMEFILTER® discs and their gap size depends on the arrester's conditions of use.

By indicating the operating parameters such as temperature, pressure and explosion group, and the composition of the fluid, the optimum detonation arrester can be selected from a series of approved devices. The PROTEGO® DA-SB flame arresters are available for all explosion groups.

The standard design can be used up to an operating temperature of +60°C / 140°F and an absolute operating pressure up to 1.1 bar / 15.9 psi. Numerous devices with special approval can be obtained for higher pressures (see table 3) and higher temperatures.

Type-approved according to ATEX Directive 94/9/EC and EN ISO 16852 as well as other international standards.

Special Features and Advantages

- optimized performance from the patented *Shock Wave Guide Tube Effect (SWGTE)*
- less number of FLAMEFILTER® discs from the use of the patented shock tube (SWGTE)
- modular flame arrester unit enables each individual FLAMEFILTER® discs to be replaced and cleaned
- different series allow increase of FLAMEFILTER® size for given flange connection resulting in lower pressure drop across the device
- service-friendly design
- expanded application range for higher operating temperatures and pressures
- bidirectional operation as well as any direction of flow and installation position
- installation of temperature sensors are possible
- minimum pressure loss and associated low operating and life-cycle cost
- cost efficient spare parts

Design Types and Specifications

There are four different designs available:

Basic in-line detonation flame arrester **DA-SB - [] - []**

In-line detonation flame arrester with integrated temperature sensor* as additional protection against short time burning from one side **DA-SB - [T] - []**

In-line detonation flame arrester with two integrated temperature sensors* for additional protection against short time burning from both sides **DA-SB - [TB] - []**

In-line detonation flame arrester with heating jacket **DA-SB - [H] - []**

Additional special flame arresters upon request

*Resistance thermometer for device group II, category (1) 2 (GII cat. (1) 2)

Table 1: Dimensions

Dimensions in mm / inches

To select nominal width/nominal size (NG/DN) - combination, please use the flow capacity charts on the following pages		Additional nominal width/nominal size (NG/DN) - combinations for improved flow capacity upon request											
standard (special sizes up to NG 2000/80", DN 1000/40" available)													
NG	150 6"	150 6"	200 8"	300 12"	400 16"	500 20"	600 24"	700 28"	800 32"	1000 40"	1200 48"	1600 64"	
DN	≤ 50 2"	65, 80 2 ½", 3"	≤ 100 4"	≤ 150 6"	≤ 200 8"	≤ 250 10"	≤ 300 12"	≤ 350 14"	≤ 400 16"	≤ 500 20"	≤ 600 24"	800 32"	
a	285 / 11.22	285 / 11.22	340 / 13.39	445 / 17.52	565 / 22.24	670 / 26.38	780 / 30.71	895 / 35.24	1015 / 39.96	1230 / 48.43	1455 / 57.28	1915 / 75.39	
b	IIA-P1,1	388 / 15.28	388 / 15.28	476 / 18.74	626 / 24.65	700 / 27.56	800 / 31.50*	1000 / 39.37*	1200 / 47.24	1400 / 55.12	1600 / 62.99	1800 / 70.87	2200/ 86.61**
	IIA-P1,4-X3	400 / 15.75	400 / 15.75	488 / 19.21	626 / 24.65	724 / 28.50	800 / 31.50	1000 / 39.37	1200 / 47.24	1400 / 55.12			
	IIB3-P1,1	400 / 15.75	412 / 16.22	500 / 19.69	650 / 25.59	724 / 28.50	824 / 32.44	1000 / 39.37	1200 / 47.24	1400 / 55.12	1600 / 62.99	1800 / 70.87	
	IIB3-P1,4-X3	412 / 16.22	412 / 16.22	512 / 20.16	650 / 25.59	724 / 28.50	824 / 32.44	1000 / 39.37	1200 / 47.24	1400 / 55.12			
	IIC-P1,1	400 / 15.75	400 / 15.75	500 / 19.69	638 / 25.12	700 / 27.56	788 / 31.02	1000 / 39.37***	1200 / 47.24***	1400 / 55.12***			
c	500 / 19.69	500 / 19.69	520 / 20.47	570 / 22.44	620 / 24.41	670 / 26.38	720 / 28.35	770 / 30.31	820 / 32.28	950 / 37.40	1050 / 41.34	1250 / 49.21	

* dimension b only for P1.4 / 20.3

** dimension b only for P1.2 / 17.4

*** EN 12874

Table 2: Selection of the explosion group

MESG	Expl. Gr. (IEC/CEN)	Gas Group (NEC)	Special approvals upon request
> 0,90 mm	IIA	D	
≥ 0,65 mm	IIB3	C	
< 0,50 mm	IIC	B	

Table 3: Selection of max. operating pressure

NG		150 6"	150 6"	200 8"	300 12"	400 16"	500 20"	600 24"	700 28"	800 32"	1000 40"	1200 48"	1600 64"	
DN		≤ 50 2"	65, 80 2 ½", 3"	≤ 100 4"	≤ 150 6"	≤ 200 8"	≤ 250 10"	≤ 300 12"	≤ 350 14"	≤ 400 16"	≤ 500 20"	≤ 600 24"	800 32"	
Expl. Gr.	IIA	P _{max}	2.1 / 30.5	2.1 / 30.5	2.1 / 30.5	2.1 / 30.5	2.1 / 30.5	2.1 / 30.5	1.4 / 20.3	1.4 / 20.3	1.4 / 20.3	1.1 / 15.9	1.1 / 15.9	1.2 / 17.4
	IIB3	P _{max}	1.4 / 20.3	1.4 / 20.3	1.4 / 20.3	1.8 / 26.1	1.8 / 26.1	1.8 / 26.1	1.8 / 26.1	1.4 / 20.3	1.4 / 20.3	1.1 / 15.9	1.1 / 15.9	
	IIC	P _{max}	2.2 / 31.9	2.2 / 31.9	1.1 / 15.9	1.1 / 15.9	1.1 / 15.9	1.1 / 15.9	1.1 / * 15.9	1.1 / * 15.9	1.1 / * 15.9			

 P_{max} = maximum allowable operating pressure in bar / psi absolut, higher operating pressure upon request

 in-between size up to P_{max} upon request

* capacity charts upon request



for safety and environment

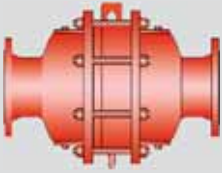

In-Line Detonation Flame Arrester

for stable detonations and deflagrations in a straight through design with shock tube, bidirectional

PROTEGO® DA-SB

Table 4: Specification of max. operating temperature

≤ 60°C / 140°F	≤ 200°C / 392°F	higher operating temperatures upon request
T60	T200	Tmaximum allowable operating temperature in °C
-	X3	Designation

Table 5: Material selection for housing

Design	A	B	C	
Housing	Steel	Stainless Steel	Hastelloy	The housing is also available in Steel with ECTFE coating.
Heating jacket (DA-SB-(T)-H-...)	Steel	Stainless Steel	Stainless Steel	
Gasket	PTFE	PTFE	PTFE	
Flame arrester unit	A, B	B, C, D	D	

Special materials upon request

Table 6: Material combinations of the flame arrester unit

Design	A	B	C	D	
FLAMEFILTER® cage	Steel	Stainless Steel	Stainless Steel	Hastelloy	*the FLAMEFILTER® are also available in the materials Tantalum, Inconel, Copper, etc. when the listed housing and cage materials are used.
FLAMEFILTER® *	Stainless Steel	Stainless Steel	Hastelloy	Hastelloy	
Spacer	Stainless Steel	Stainless Steel	Hastelloy	Hastelloy	

Special materials upon request

Table 7: Flange connection type

EN 1092-1, Form B1 or DIN 2501, Form C, PN 16; from DN 200 PN 10	EN or DIN	other types upon request
ANSI 150 lbs RFSF	ANSI	

* P1.4
** P1.2

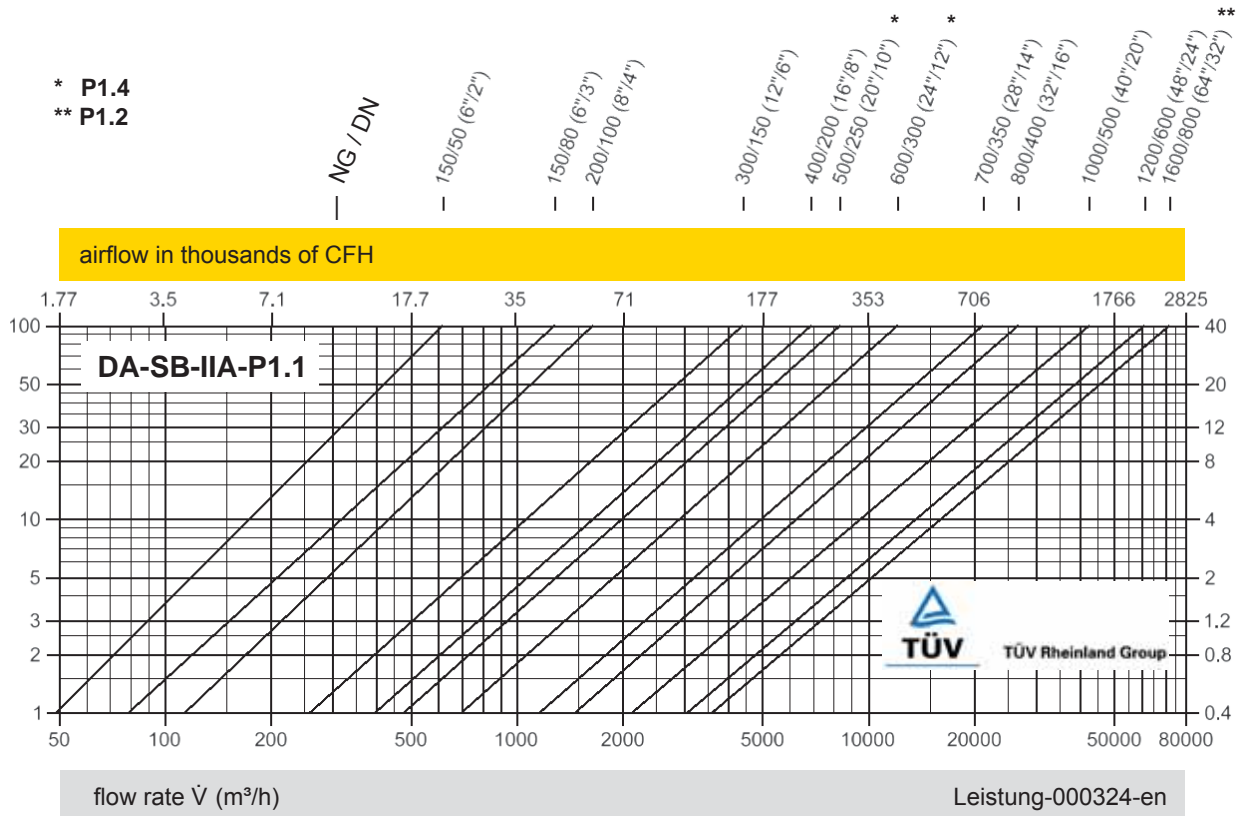

X3 maximum allowable operating temperature 200 °C

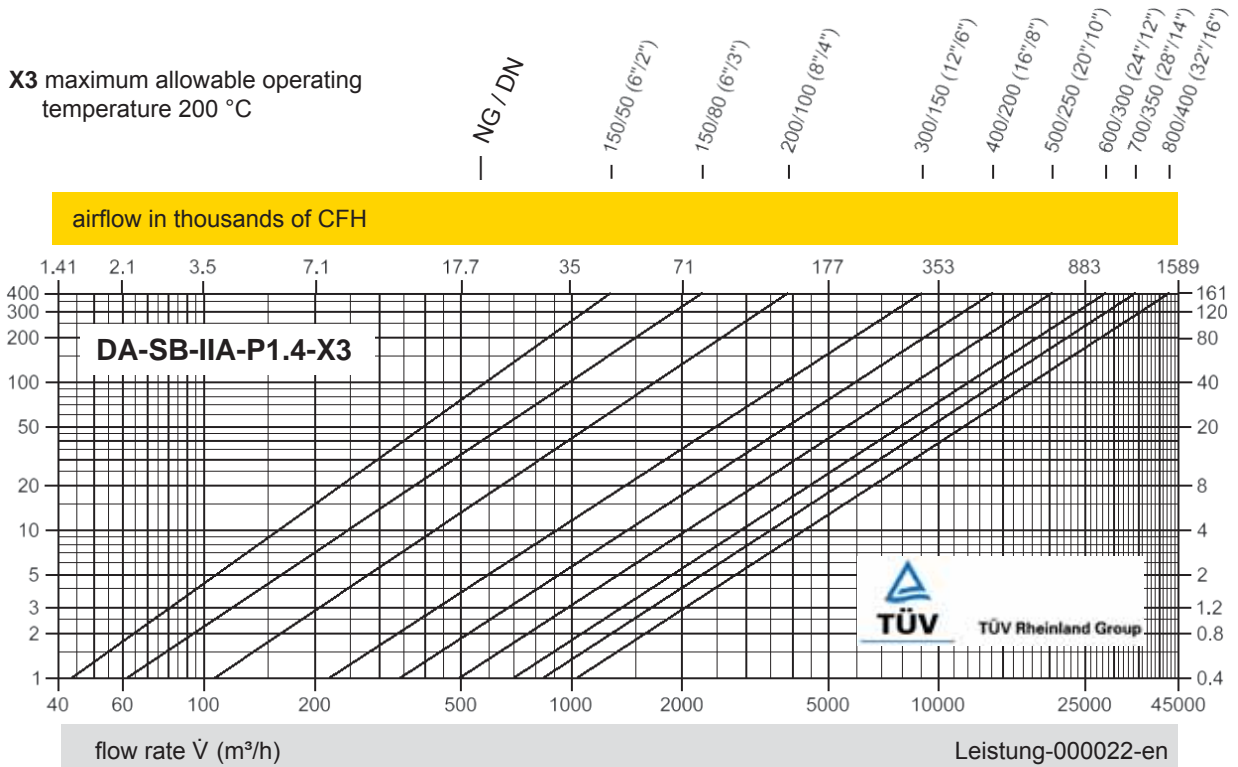

The flow capacity charts have been determined with a calibrated and TÜV certified flow capacity test rig. Volume flow \dot{V} in (m³/h) and CFH refer to the standard reference conditions of air ISO 6358 (20°C, 1bar). Conversion to other densities and temperatures refer to Vol. 1: "Technical Fundamentals".



for safety and environment

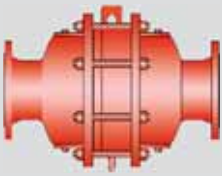

In-Line Detonation Flame Arrester

Flow Capacity Charts

PROTEGO® DA-SB

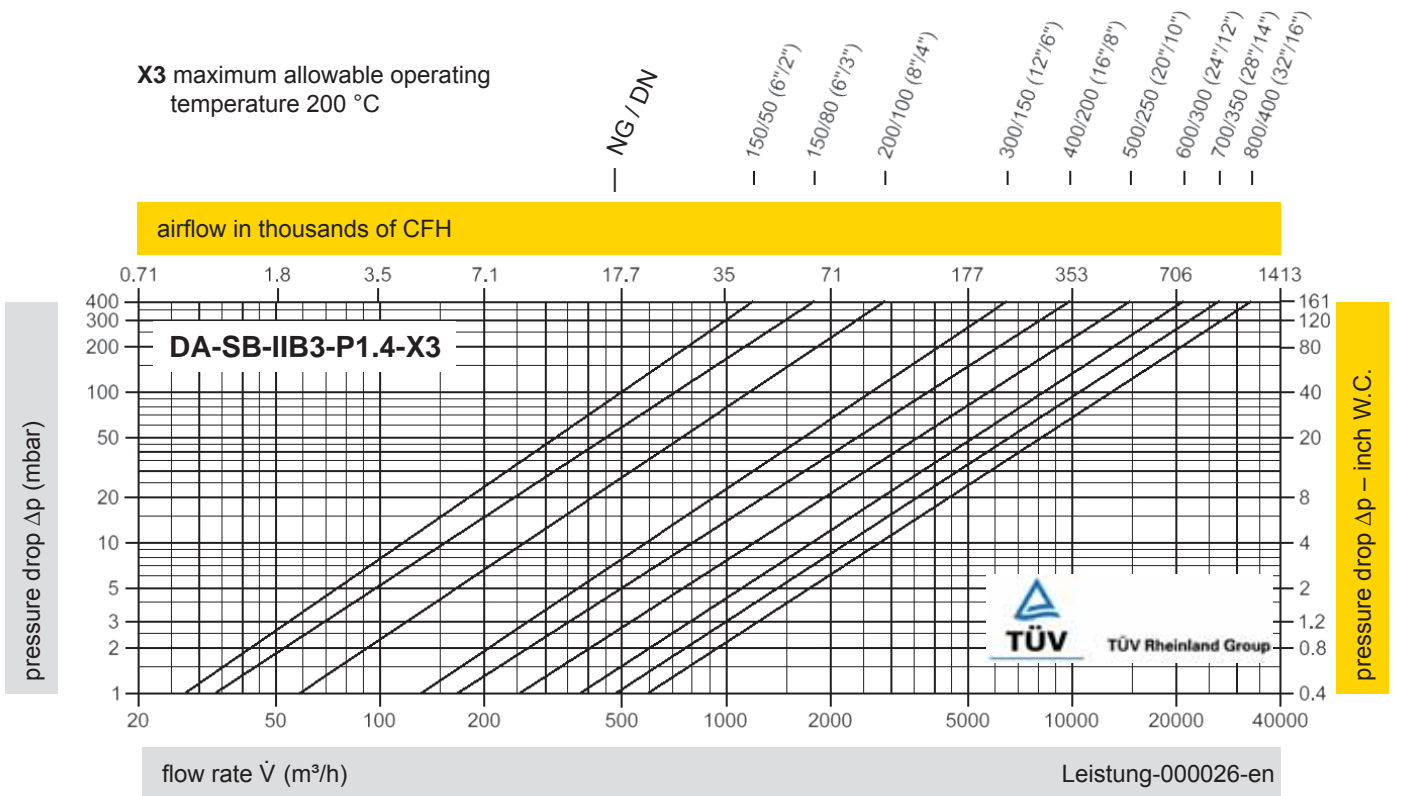
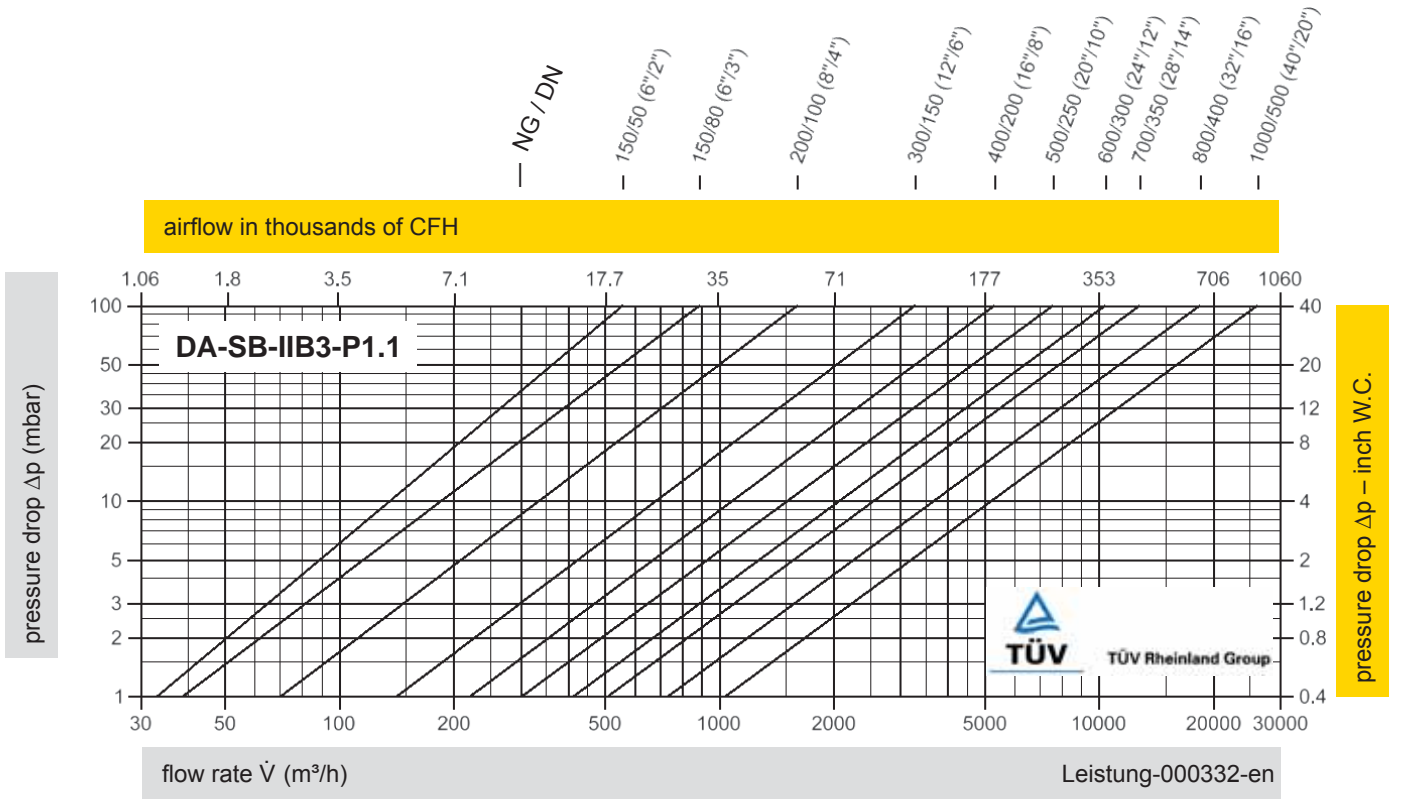

The flow capacity charts have been determined with a calibrated and TÜV certified flow capacity test rig. Volume flow \dot{V} in (m³/h) and CFH refer to the standard reference conditions of air ISO 6358 (20°C, 1bar). Conversion to other densities and temperatures refer to Vol. 1: "Technical Fundamentals".

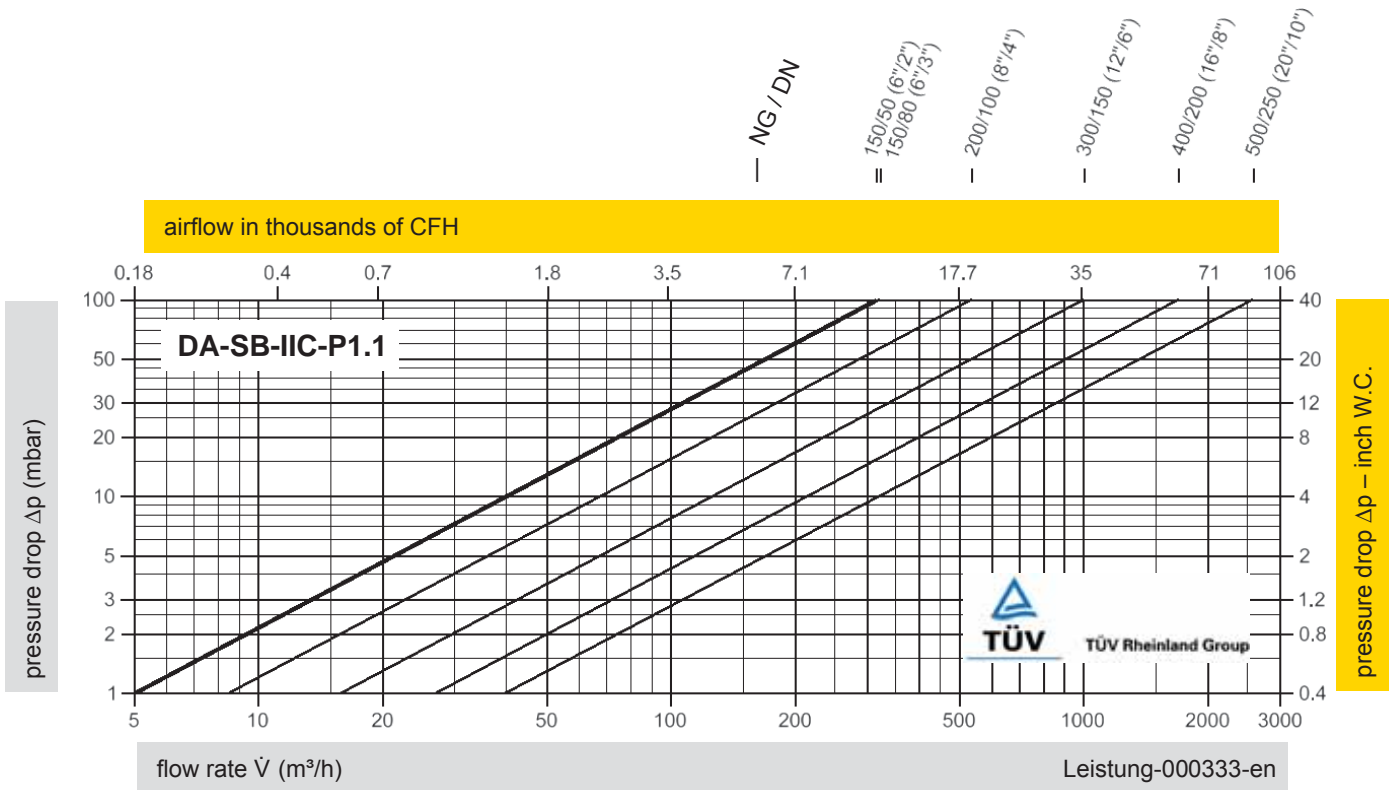

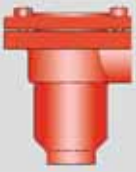

In-Line Detonation Flame Arrester

for stable detonations and deflagrations in right angle design,
unidirectional

PROTEGO® DR/ES

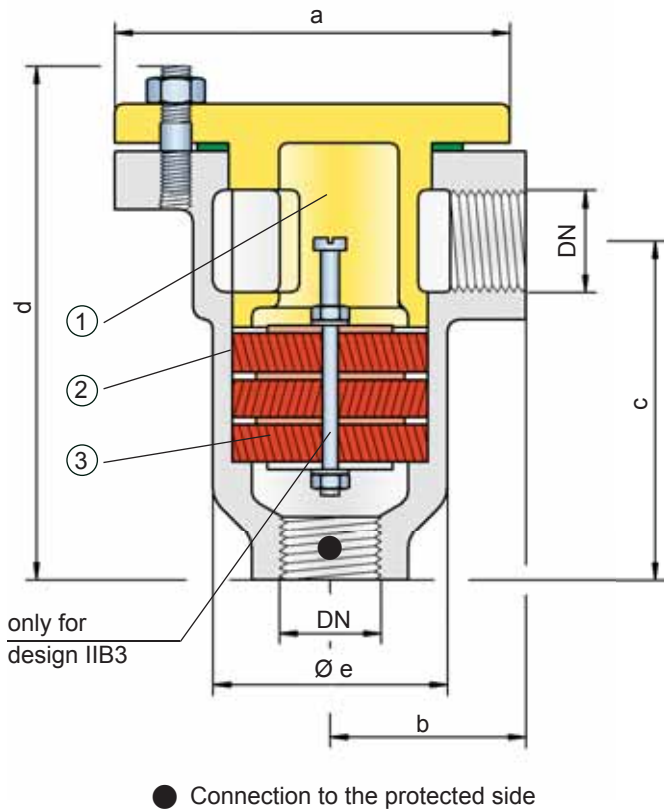

Function and Description

The PROTEGO® DR/ES series in-line detonation flame arrester with connection size up to ¾" is ideal for installation in small pipes and to protect equipment such as gas analyzers. The device protects against deflagrations and stable detonations. It can be installed anywhere in the pipe no matter what the distance is from the potential ignition source. The small and compact flame arrester has a right angle design.

Once a detonation enters the flame arrester, energy is absorbed from the detonation shock wave by diversion mainly through the shock absorber (1) before the flame is extinguished in the narrow gaps of the FLAMEFILTER® (3).

The PROTEGO® flame arrester unit (2) consists of several FLAMEFILTER® discs and spacers (for explosion group IIC - NEC group B) whose gap size and number is determined by the operating parameters of the processed fluid (explosion group, pressure, temperature). This device is available for explosion groups IIB3 and IIC (NEC group C MESH ≥ 0.65 mm and B).

This in-line detonation flame arrester functions unidirectional and is equipped with a threaded connection. The thread can be adapted to international standards. The standard design is approved at an operating temperature up to +60°C / 140°F and an absolute operating pressure acc. to table 3. Devices with special approvals can be obtained for higher pressures and higher temperatures upon request.

Type-approved according to ATEX Directive 94/9/EC and EN ISO 16852 as well as other international standards.

Special Features and Advantages

- compact design
- minimum number of FLAMEFILTER® discs due to shock absorber technology and optimal geometry
- Design for IIB3:
 - the device can be serviced without disconnecting the pipe
 - the individual FLAMEFILTER® can be quickly removed and installed
- provides protection from deflagration and stable detonation
- through right angle design no pipe elbows are needed
- works for nearly any flammable gas and gas mixture
- low life-cycle cost
- cost efficient spare parts

Table 1: Dimensions

Dimensions in mm / inches

To select the nominal size (DN), please use the flow capacity charts on the following pages

DN	G ¼"	G ½"	G¾"
a	48 / 1.89	70 / 2.76	80 / 3.15
b	35 / 1.38	40 / 1.57	47 / 1.85
c	70 / 2.76	75 / 2.95	87 / 3.43
d	108 / 4.25	115 / 4.53	135 / 5.31
e	34 / 1.34	50 / 1.97	60 / 2.36

Table 2: Selection of the explosion group

MESG	Expl. Gr. (IEC/CEN)	Gas Group (NEC)	Special approvals upon request
≥ 0,65 mm	IIB3	C	
< 0,50 mm	IIC	B	

Table 3: Selection of max. operating pressure

Expl. Gr.	DN	G¼"	G ½"	G¾"	P _{max} = maximum allowable operating pressure in bar / psi (absolute), higher operating pressure upon request Expl. Gr. IIB3 covers Expl. Gr. IIA
IIC	P _{max}	1.1 / 15.9	1.1 / 15.9	1.1 / 15.9	

Table 4: Specification of max. operating temperature

≤ 60°C / 140°F	higher operating temperatures upon request
T60	T _{maximum allowable operating temperature in °C}

Table 5: Material selection for housing

Design	B	C	D	G ¼" only comes in design C and D * G ¼" without shock absorber
Housing	Steel	Stainless Steel	Hastelloy	
Cover with shock absorber*	Steel	Stainless Steel	Hastelloy	
Gasket	PTFE	PTFE	PTFE	
Flame arrester unit	A	A	B	

Special materials upon request

Table 6: Material combinations of the flame arrester unit

Design	A	B	* the FLAMEFILTER® are also available in the materials Tantalum, Inconel, Copper, etc. when the listed housing and cage materials are used.
FLAMEFILTER® *	Stainless Steel	Hastelloy	
Spacer	Stainless Steel	Hastelloy	

Special materials upon request

Table 7: Type of connection

Pipe thread DIN ISO 228-1	DIN	other types of thread upon request
---------------------------	-----	------------------------------------



for safety and environment

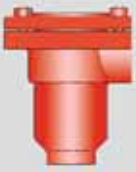

In-Line Detonation Flame Arrester

Flow Capacity Charts

PROTEGO® DR/ES

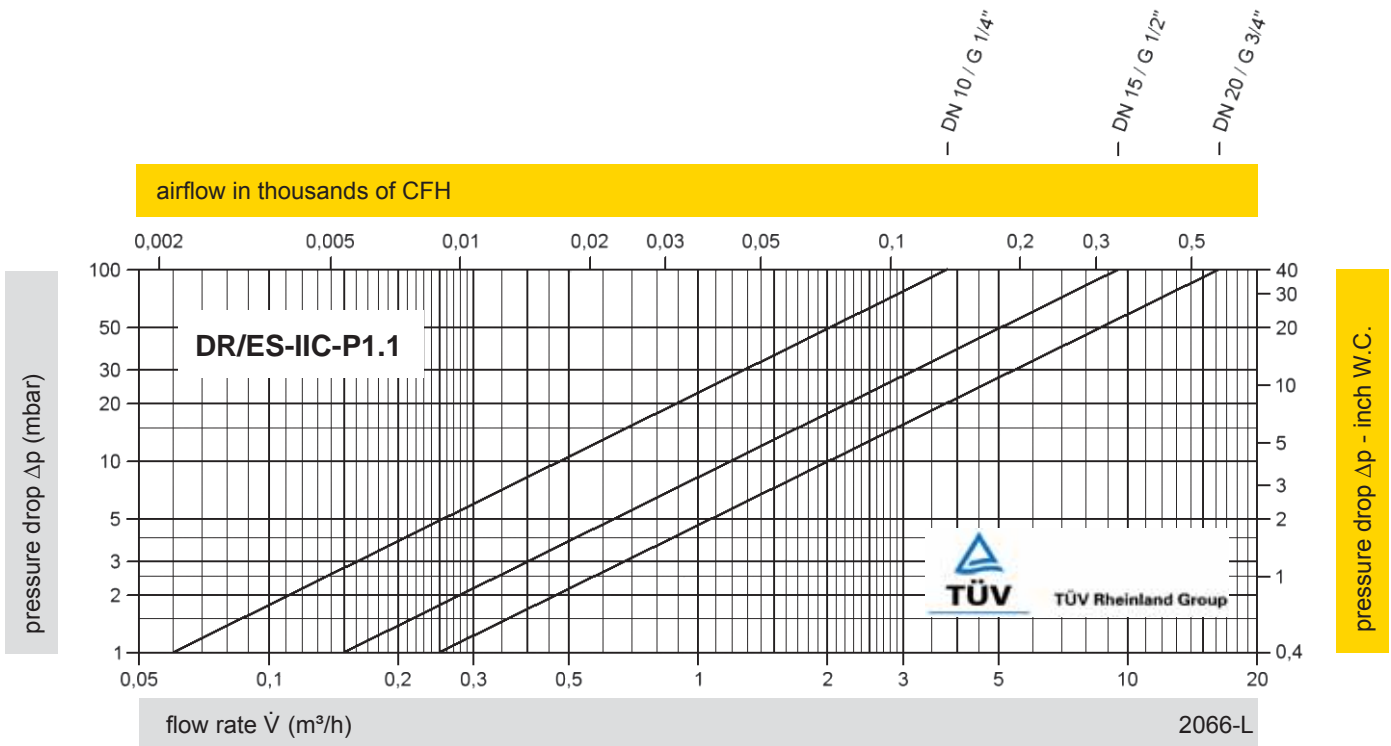
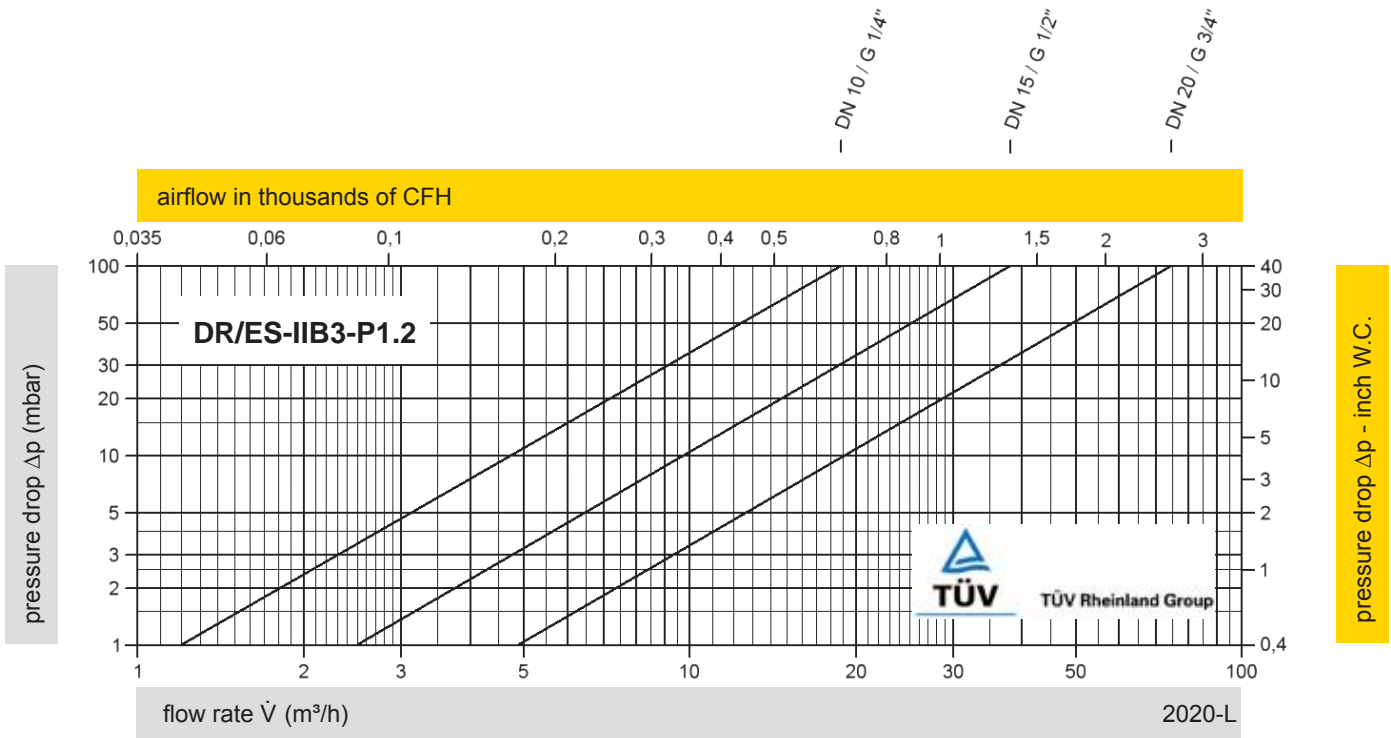

The flow capacity charts have been determined with a calibrated and TÜV certified flow capacity test rig.

Volume flow \dot{V} in (m³/h) and CFH refer to the standard reference conditions of air ISO 6358 (20°C, 1bar). Conversion to other densities and temperatures refer to Vol. 1: "Technical Fundamentals".

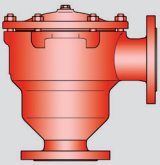

In-Line Detonation Flame Arrester

for stable detonations and deflagrations in right angle design with shock absorber, unidirectional

PROTEGO® DR/ES

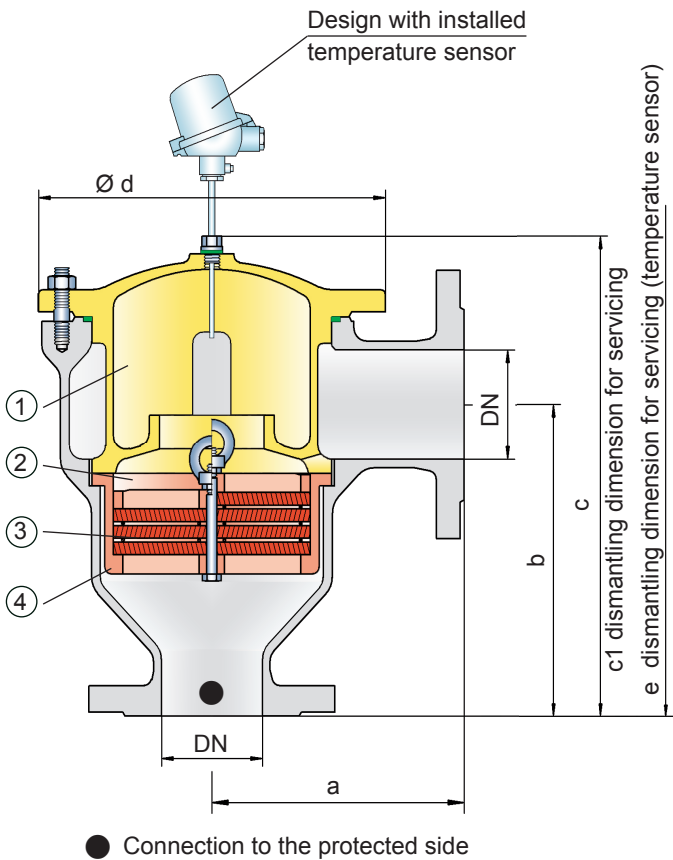

The standard design is approved at an operating temperature up to +60°C / 140°F and an absolute operating pressure up to 1.2 bar / 17.4 psi. Devices with special approvals can be obtained for higher pressures and higher temperatures upon request.

Type-approved according to ATEX Directive 94/9/EC and EN ISO 16852 as well as other international standards.

Special Features and Advantages

- minimum number of FLAMEFILTER® discs due to the effective shock absorber
- quick removal and installation of the complete PROTEGO® flame arrester unit and FLAMEFILTER® discs in the cage
- due to modular design the FLAMEFILTER® discs can be individually replaced
- the right angle design saves pipe elbows
- extended application range for higher operating temperatures and pressures
- minimum pressure loss and hence low operating and life-cycle cost
- cost efficient spare parts

Design Types and Specifications

There are four different designs available:

- Basic in-line detonation flame arrester **DR/ES-** -
- In-line detonation flame arrester with integrated temperature sensor* as additional protection against short time burning **DR/ES-** **T** -
- In-line detonation flame arrester with heating jacket **DR/ES-** **H** -
- In-line detonation flame arrester with integrated temperature sensor* against short time burning and heating jacket **DR/ES-** **H** - **T**

*Resistance thermometer for device group II, category (1) 2 (GII cat. (1) 2)

Function and Description

The PROTEGO® DR/ES in-line detonation flame arrester has been used for decades in industrial plant construction because its right angle design offers advantages towards maintenance and costs in comparison to most straight designs.

Once a detonation enters the device, energy is absorbed from the detonation shock wave by the integrated shock absorber (1) before the flame is extinguished in the narrow gaps of the FLAMEFILTER® (3).

The PROTEGO® flame arrester unit (2) consists of several FLAMEFILTER® discs and spacers firmly held in the FLAMEFILTER® cage (4). The gap size and number of FLAMEFILTER® discs are determined by the operating data of the mixture flowing in the line (explosion group, pressure, temperature). This device is approved for explosion groups from IIA to IIB3 (NEC group D to C MESH ≥ 0.65 mm).

Table 1: Dimensions

Dimensions in mm / inches

To select the nominal size (DN), please use the flow capacity charts on the following pages

DN	25 / 1"	32 / 1 ¼"	40 / 1 ½"	50 / 2"	65 / 2 ½"	80 / 3"	100 / 4"	125 / 5"	150 / 6"	200 / 8"
a	125/4.92	125/4.92	153/6.02	155/6.10	198/7.80	200/7.87	250/9.84	332/13.07	335/13.19	425/16.73
b	140/5.51	140/5.51	183/7.20	185/7.28	223/8.78	225/8.86	290/11.42	357/14.06	360/14.07	505/19.88
c	210/8.27	210/8.27	290/11.42	290/11.42	365/14.37	365/14.37	440/17.32	535/21.06	535/21.06	810/31.89
c1	285/11.22	285/11.22	395/15.55	395/15.55	500/19.69	500/19.69	595/23.43	750/29.53	750/29.53	1230/48.43
d	150/5.91	150/5.91	210/8.27	210/8.27	275/10.83	275/10.83	325/12.80	460/18.11	460/18.11	620/24.41
e	495/19.49	495/19.49	600/23.62	600/23.62	705/27.76	705/27.76	795/31.30	950/37.40	950/37.40	1435/56.50

Table 2: Selection of the explosion group

MESG	Expl. Gr. (IEC/CEN)	Gas Group (NEC)	Special approvals upon request
> 0,90 mm	IIA	D	
≥ 0,65 mm	IIB3	C	

Table 3: Selection of max. operating pressure

DN		25 / 1"	32 / 1 ¼"	40 / 1 ½"	50 / 2"	65 / 2 ½"	80 / 3"	100 / 4"	125 / 5"	150 / 6"	200 / 8"
Expl. Gr.	IIA P _{max}	4.0/58.0	4.0/58.0	4.0/58.0	4.0/58.0	2.9/42.1	2.9/42.1	2.0/29.0	2.0/29.0	2.0/29.0	1.2/17.4
	IIB3 P _{max}	3.0/43.5	3.0/43.5	2.0/29.0	2.0/29.0	2.0/29.0	2.0/29.0	1.5/21.7	1.4/20.3	1.4/20.3	1.1/15.9

P_{max} = maximum allowable operating pressure in bar / psi (absolute), higher operating pressure upon request**Table 4: Specification of max. operating temperature**

≤ 60°C / 140°F	higher operating temperatures upon request
T60	Tmaximum allowable operating temperature in °C

Table 5: Material selection for housing

Design	B	C	D	* for devices exposed to elevated temperatures above 150°C / 302°F (T150), gaskets made of PTFE. The housing and cover with the shock absorber can also be delivered in steel with an ECTFE coating. Special materials upon request
Housing	Steel	Stainless Steel	Hastelloy	
Heating jacket (DR/ES-H-(T)-...)	Steel	Stainless Steel	Stainless Steel	
Cover with shock absorber	Steel	Stainless Steel	Hastelloy	
O-Ring	FPM*	PTFE	PTFE	
Flame arrester unit	A	C, D	E	

Table 6: Material combinations of the flame arrester unit

Design	A	C	D	E	* the FLAMEFILTER® are also available in the materials Tantalum, Inconel, Copper, etc. when the listed housing and cage materials are used.
FLAMEFILTER® cage	Steel	Stainless Steel	Stainless Steel	Hastelloy	
FLAMEFILTER® *	Stainless Steel	Stainless Steel	Hastelloy	Hastelloy	
Spacer	Stainless Steel	Stainless Steel	Hastelloy	Hastelloy	

Special materials upon request

Table 7: Flange connection type

EN 1092-1, Form B1 or DIN 2501, Form C, PN 16; from DN 200 PN 10	EN or DIN	other types upon request
ANSI 150 lbs RFSF	ANSI	



for safety and environment

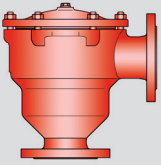

In-Line Detonation Flame Arrester

Flow Capacity Charts

PROTEGO® DR/ES

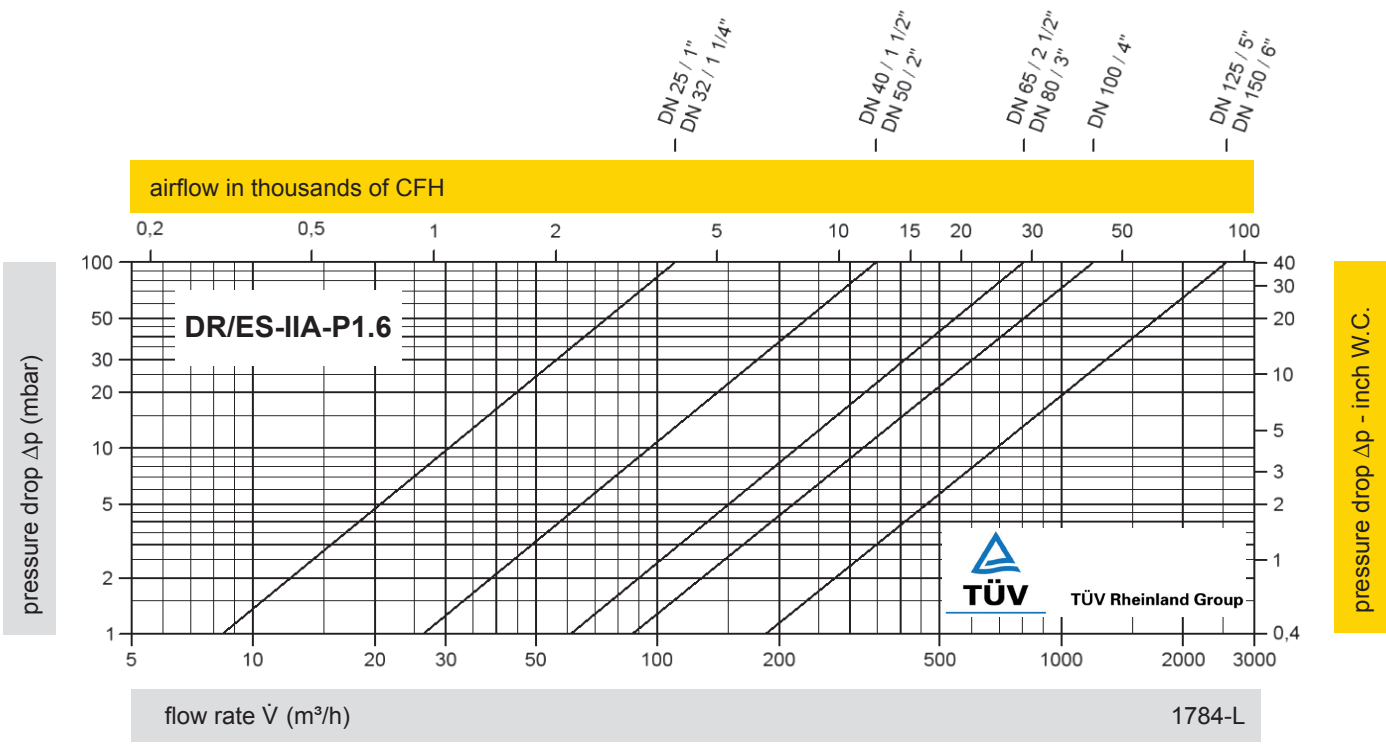
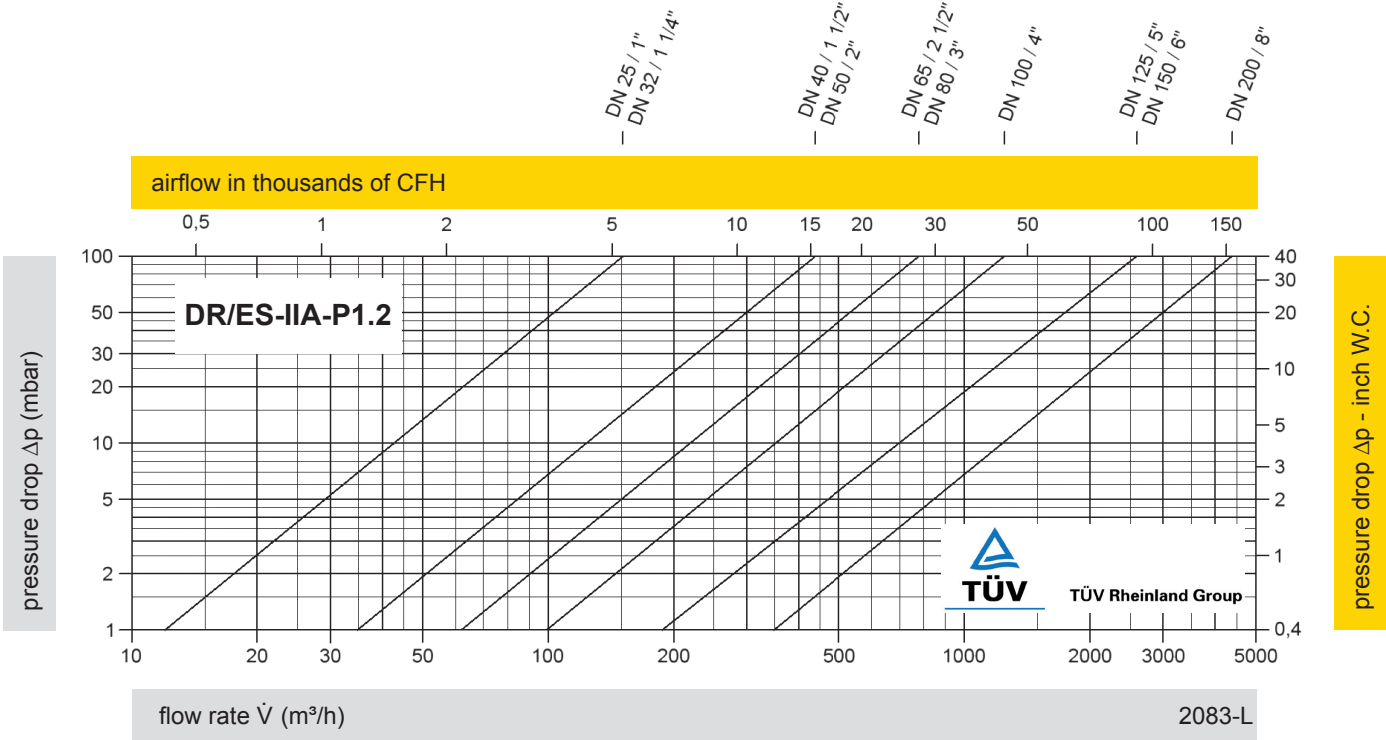

The flow capacity charts have been determined with a calibrated and TÜV certified flow capacity test rig. Volume flow \dot{V} in (m³/h) and CFH refer to the standard reference conditions of air ISO 6358 (20°C, 1bar). Conversion to other densities and temperatures refer to Vol. 1: "Technical Fundamentals".

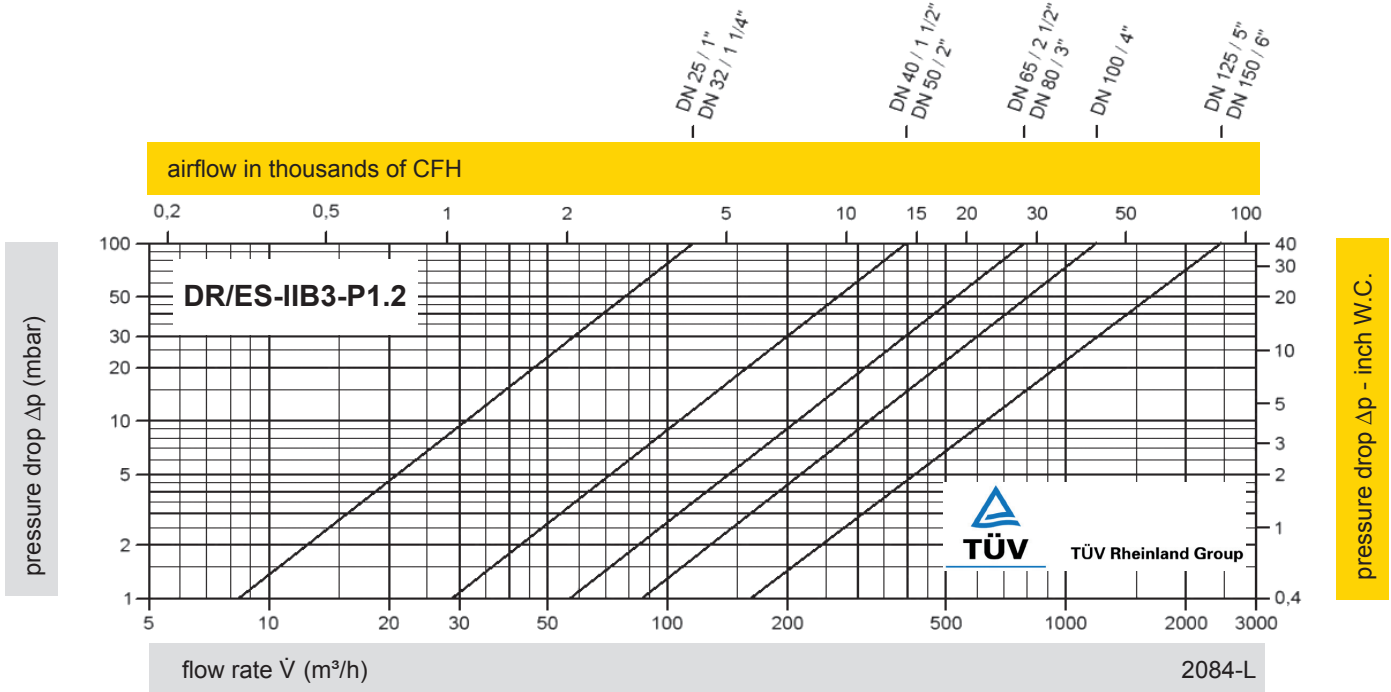

- * DN 25 - DN 80; P1.6
- DN 100; P1.5
- DN 125, DN 150; P1.4
- DN 200; P1.1

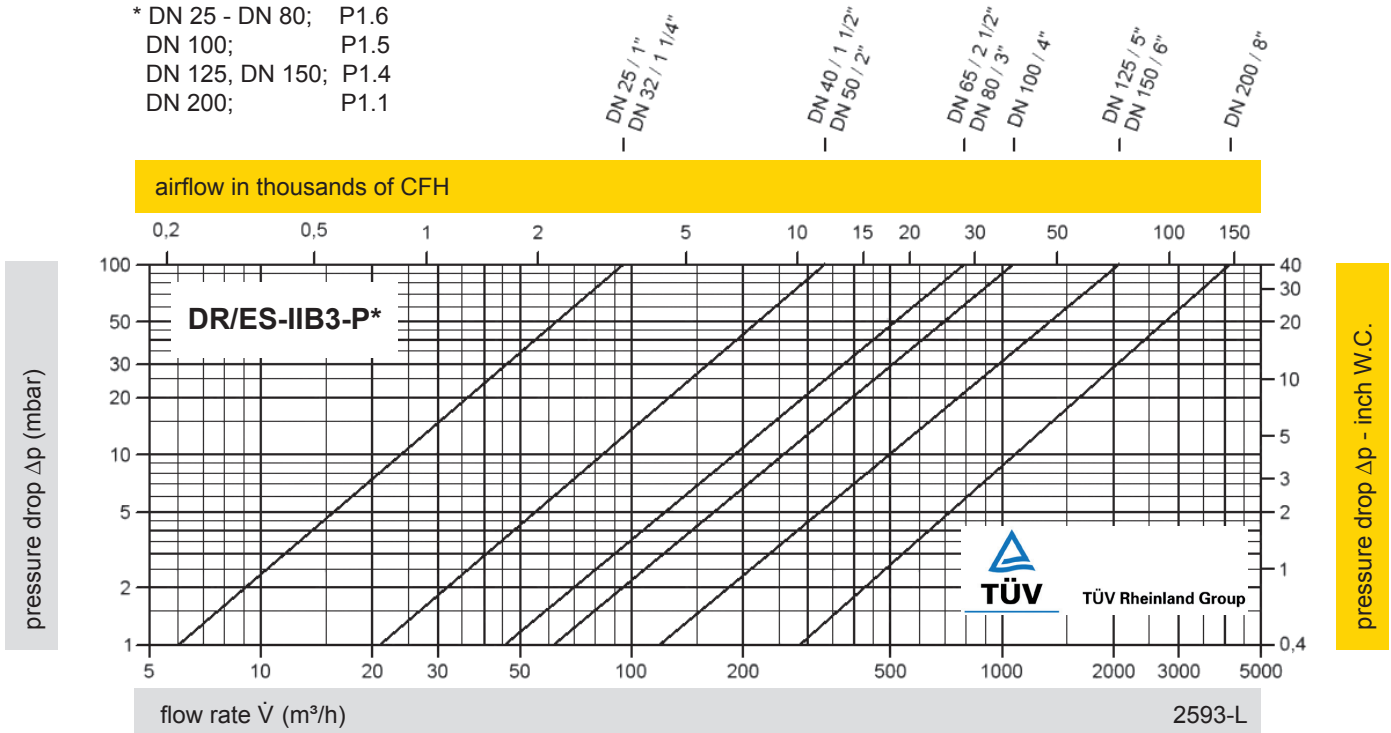

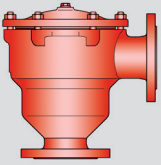

In-Line Detonation Flame Arrester

Flow Capacity Charts (liquid)

PROTEGO® DR/ES

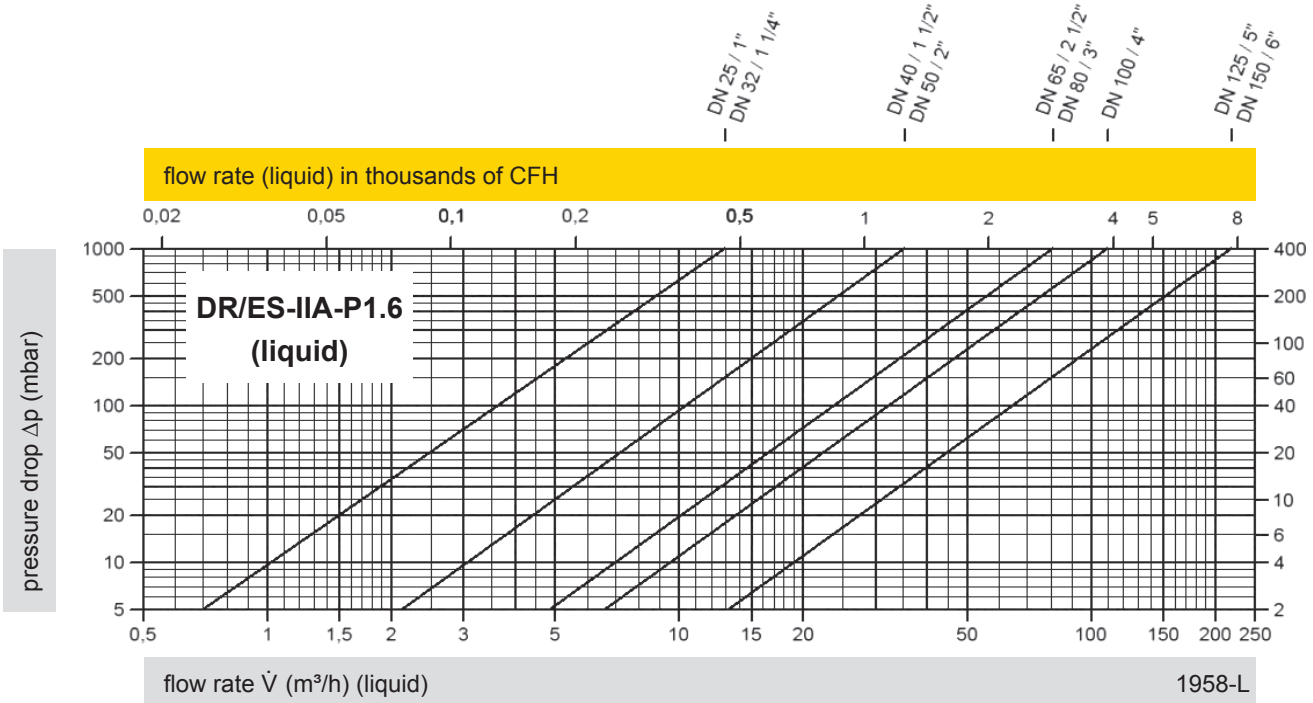

- * DN 25 - DN 80; P1.6
- DN 100; P1.5
- DN 125, DN 150; P1.4
- DN 200; P1.1

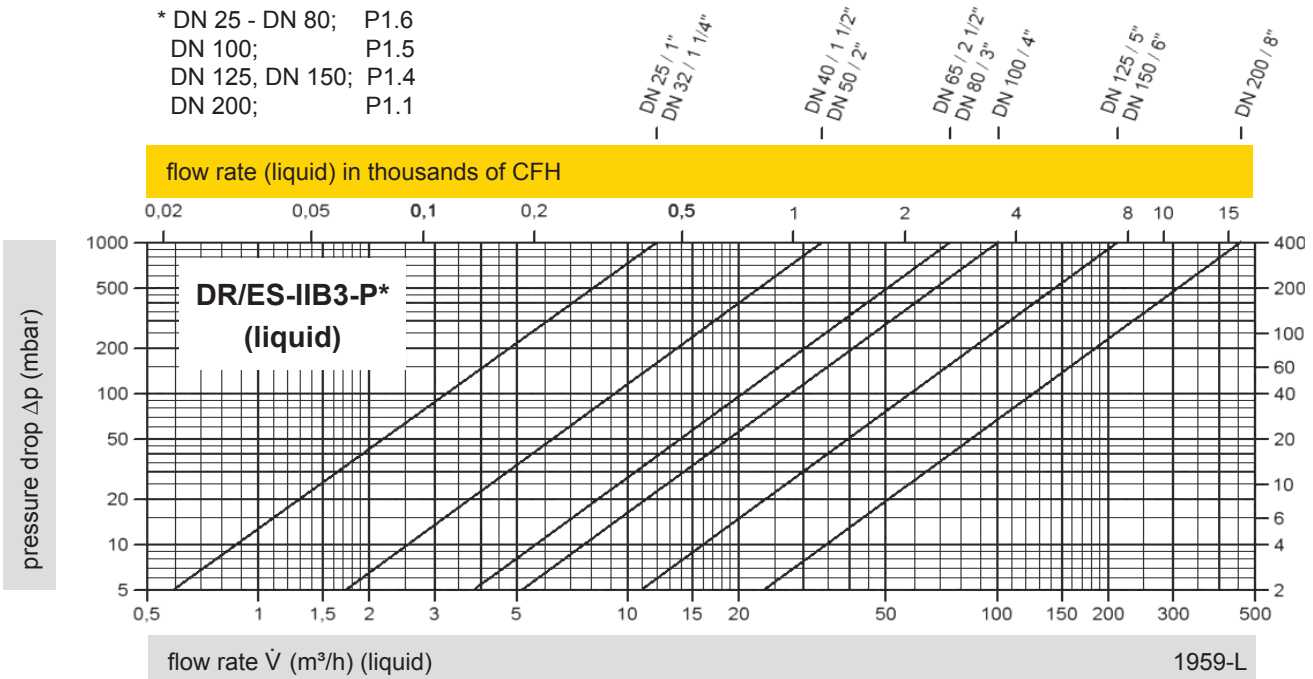

Conversion: $\dot{V}_{liquid} = \dot{V}_{water} * \sqrt{\frac{\rho_{water}}{\rho_{liquid}}}$

The volume flow \dot{V} in m³/h was determined with water according to DIN EN 60534 at a temperature $T_n = 15^\circ\text{C}$ and an atmospheric pressure $p_n = 1,013 \text{ bar}$, kinematic viscosity $\nu = 10^{-6} \text{ m}^2/\text{s}$



In-Line Detonation Flame Arrester

with integrated pressure relief valve, for stable detonations and deflagrations
in right angle design with shock absorber, unidirectional

PROTEGO® DR/ES-V

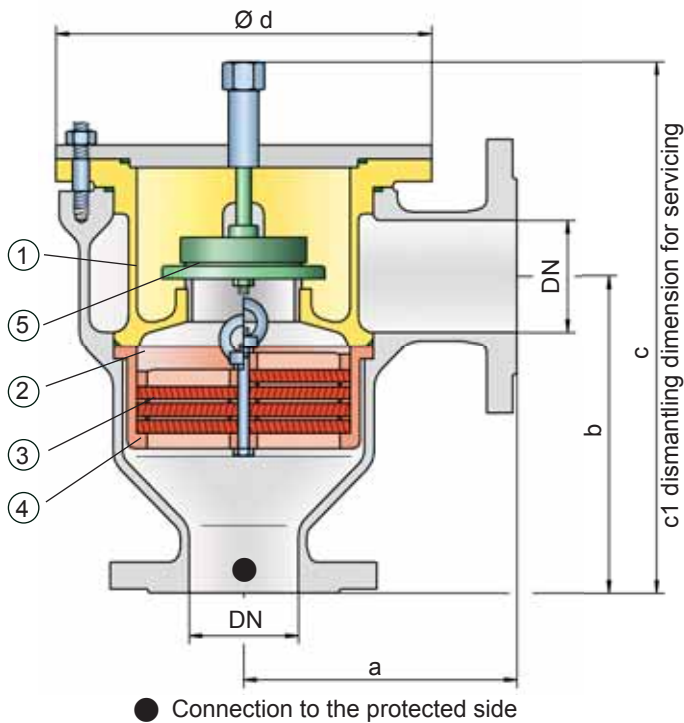

Set pressure: from +2.0 mbar up to +35 mbar
from +0.8 inch W.C. up to +14 inch W.C.

Higher or lower settings upon request

Function and Description

PROTEGO® DR/ES-V series uniquely combines the function of an in-line detonation flame arrester with the function of a pressure relief valve in one device. The device protects against deflagration and stable detonation. The weight-loaded pallet type valve (5) integrated in the shock absorber (1) of the in-line detonation flame arrester is designed as pressure relief valve. The set pressure of the valve is adjusted in the factory and can range from 2 to 35 mbar (0.8 to 14 inch W.C.). After the pressure increases 40% from its set pressure, the valve completely opens to yield the maximum volumetric flow. If installed in vent headers connected to storage tanks, the valve pallet works as check valve. This means that the product can not flow back from the suction line into the tank. Although several functions are integrated in a single housing, the device is extremely easy to service, which is primarily due to the classic right angle design.

Once a detonation enters the flame arrester, energy is absorbed from the detonation shock wave by the integrated shock

absorber, before the flame is extinguished in the narrow gaps of the FLAMEFILTER® (3). The flame suppression is guaranteed independent of the valve pallet position.

The PROTEGO® flame arrester unit (2) consists of several FLAMEFILTER® discs and spacers firmly held in the FLAMEFILTER® cage (4). The gap size and number of FLAMEFILTER® discs are determined by the operating data parameters of the mixture flowing in the line (explosion group, pressure, temperature). This device is available for explosion groups from IIA to IIB3 (NEC group D to C MESH ≥ 0.65 mm).

The standard design is approved at an operating temperature up to +60°C / 140°F and absolute operating pressure up to 1.2 bar / 17.4 psi. Devices with special approvals can be obtained for higher pressures and higher temperatures upon request.

Type-approved according to ATEX Directive 94/9/EC and EN ISO 16852 as well as other international standards.

Special Features and Advantages

- integration of in-line detonation flame arrester and pressure relief valve in one device
- excellent tightness of the valve
- applicable as a detonation-proof check valve in suction lines of storage tanks
- optimum for use as an overflow valve in venting and recovering vapour lines
- minimum number of FLAMEFILTER® discs due to the effective shock absorber
- quick removal and installation of the complete PROTEGO® flame arrester unit and the individual FLAMEFILTER® discs in the cage
- provides protection from deflagration and stable detonations
- extended application range for higher operating temperatures and pressures
- cost efficient spare parts

Design Types and Specifications

There are two different designs available:

Basic version of the detonation arrester with check valve **DR/ES--**

Detonation arrester with check valve and heating jacket **DR/ES--**

Table 1: Dimensions

Dimensions in mm / inches

To select the nominal size (DN), please use the flow capacity charts on the following pages

DN	25 / 1 / 32 / 1 1/4"	40 / 1 1/2"	50 / 2"	65 / 2 1/2"	80 / 3"	100 / 4"	125 / 5"	150 / 6"	200 / 8"
a	125 / 4.92	153 / 6.02	155 / 6.10	198 / 7.80	200 / 7.87	250 / 9.84	332 / 13.07	335 / 13.19	425 / 16.73
b	140 / 5.51	183 / 7.20	185 / 7.28	223 / 8.78	225 / 8.86	290 / 11.42	357 / 14.06	360 / 14.17	505 / 19.88
c	237 / 9.33	305 / 12.01	305 / 12.01	395 / 15.55	395 / 15.55	460 / 18.11	575 / 22.64	575 / 22.64	863 / 33.98
c1	345 / 13.58	410 / 16.14	410 / 16.14	530 / 20.87	530 / 20.87	615 / 24.21	790 / 31.10	790 / 31.10	1295 / 50.98
d	149 / 5.87	210 / 8.27	210 / 8.27	275 / 10.83	275 / 10.83	325 / 12.80	460 / 18.11	460 / 18.11	620 / 24.41

Table 2: Selection of the explosion group

MESG	Expl. Gr. (IEC/CEN)	Gas Group (NEC)	Special approvals upon request
> 0,90 mm	IIA	D	
≥ 0,65 mm	IIB3	C	

Table 3: Selection of max. operating pressure

Expl. Gr.	DN	25 / 1	32 / 1 ¼"	40 / 1 ½"	50 / 2"	65 / 2 ½"	80 / 3"	100 / 4"	125 / 5"	150 / 6"	200 / 8"
IIA	P _{max}	4.0/58.0	4.0/58.0	4.0/58.0	4.0/58.0	2.9/42.1	2.9/42.1	2.0/29.0	2.0/29.0	2.0/29.0	1.2/17.4
IIB3	P _{max}	3.0/43.5	3.0/43.5	2.0/29.0	2.0/29.0	2.0/29.0	2.0/29.0	1.5/21.7	1.4/20.3	1.4/20.3	1.1/15.9

P_{max} = maximum allowable operating pressure in bar / psi (absolute), higher operating pressure upon request

Table 4: Specification of max. operating temperature

≤ 60°C / 140°F	higher operating temperatures upon request
T60	T _{maximum allowable operating temperature in °C}

Table 5: Material selection for housing

Design	B	C	D	The housing and the cover with shock absorber can also be delivered in steel with an ECTFE coating.
Design	Steel	Stainless Steel	Hastelloy	
Heating jacket (DR/ES-V-H-...)	Steel	Stainless Steel	Stainless Steel	
Cover with shock absorber	Steel	Stainless Steel	Hastelloy	
Gaskets	PTFE	PTFE	PTFE	
Valve seat	Stainless Steel	Stainless Steel	Stainless Steel	
Flame arrester unit	A	C, D	E	

Special materials upon request

Table 6: Material combinations of the flame arrester unit

Design	A	C	D	E	* the FLAMEFILTER® are also available in the materials Tantalum, Inconel, Copper, etc. when the listed housing and cage materials are used.
FLAMEFILTER® cage	Steel	Stainless Steel	Stainless Steel	Hastelloy	
FLAMEFILTER® *	Stainless Steel	Stainless Steel	Hastelloy	Hastelloy	
Spacer	Stainless Steel	Stainless Steel	Hastelloy	Hastelloy	

Special materials upon request

Table 7: Material selection for valve pallet

Design	A	B	C
Pressure range	I	II	III
Set pressure (mbar) [inch W.C.]	+2.0 up to +3.5 +0.8 up to +1.4	>+3.5 up to +14 >+1.4 up to +5.6	>+14 up to 35 >+5.6 up to 14
Valve pallet	Aluminium	Stainless Steel	Stainless Steel
Sealing	FEP	FEP	Metal to Metal

Table 8: Flange connection type

EN 1092-1, Form B1 or DIN 2501, Form C, PN 16; from DN 200 PN 10	EN or DIN	other types upon request
ANSI 150 lbs RFSF	ANSI	



for safety and environment



In-Line Detonation Flame Arrester

Flow Capacity Charts

PROTEGO® DR/ES-V

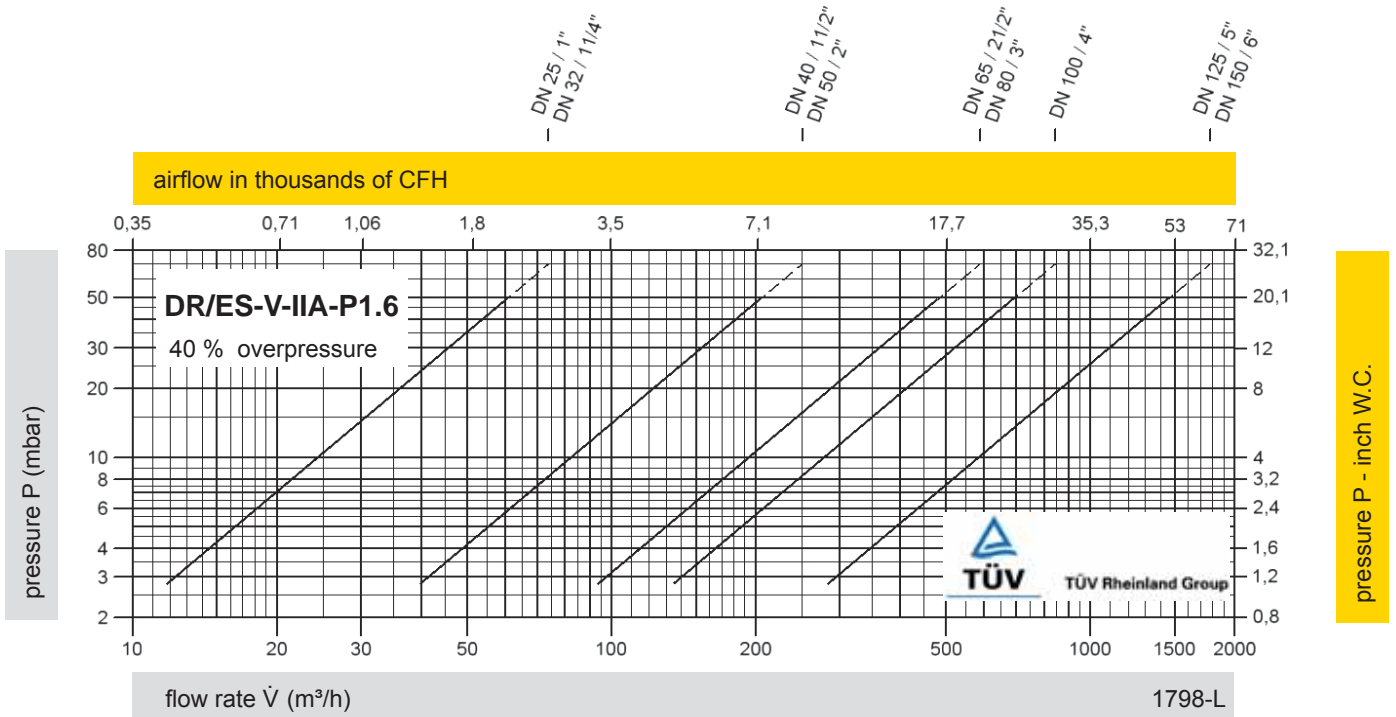
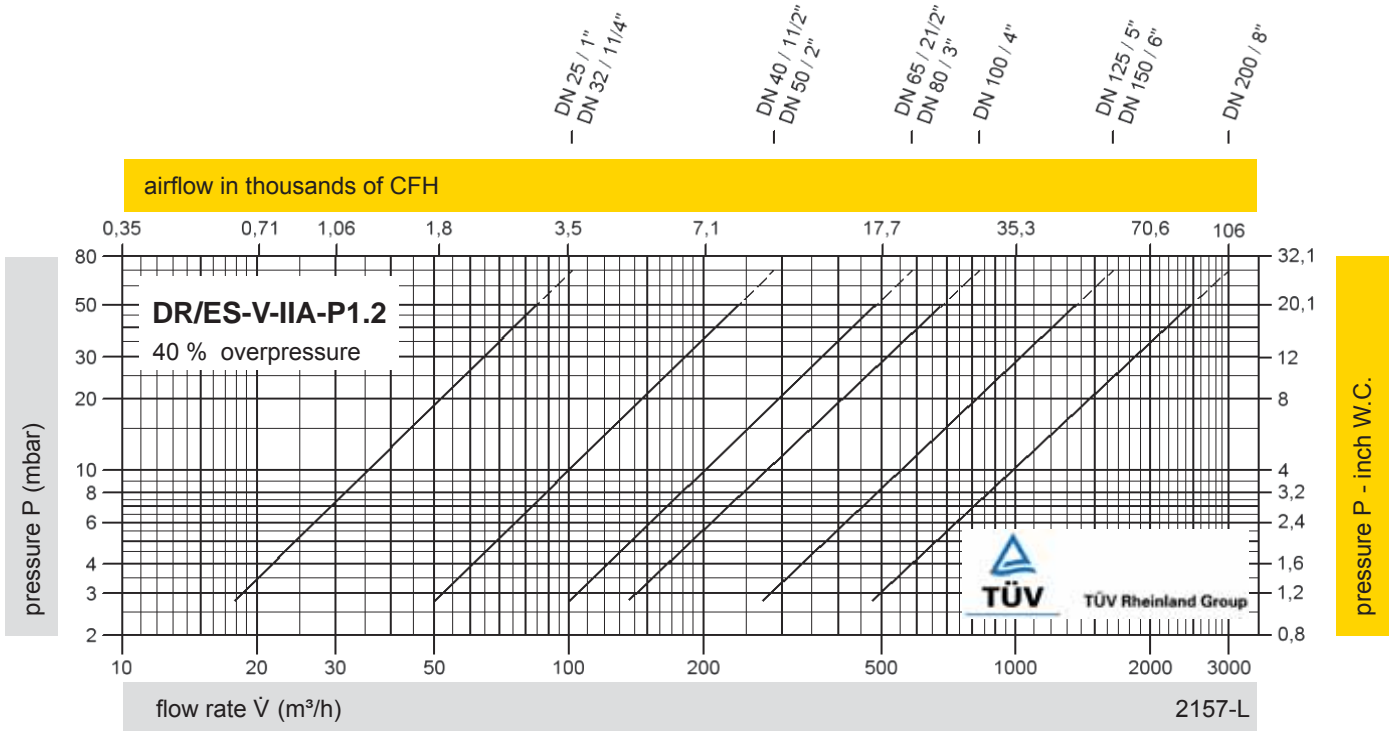

Remark

$$\text{set pressure} = \frac{\text{opening pressure resp. tank design pressure}}{1,4}$$

Set pressure = the valve starts to open

Opening pressure = set pressure plus overpressure

Overpressure = pressure increase over the set pressure

The flow capacity charts have been determined with a calibrated and TÜV certified flow capacity test rig.

Volume flow \dot{V} in (m³/h) and CFH refer to the standard reference conditions of air ISO 6358 (20°C, 1bar).

Conversion to other densities and temperatures refer to Vol. 1: "Technical Fundamentals".

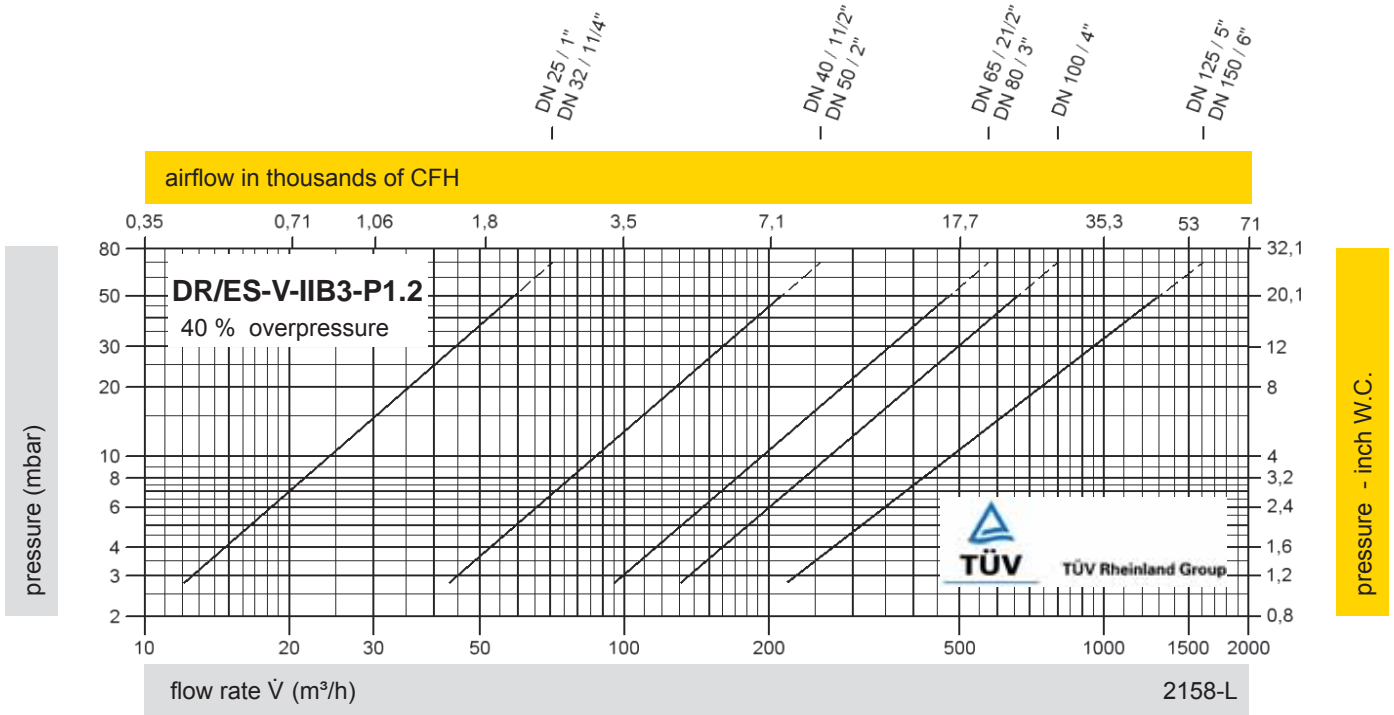

* DN 25 - DN 80; P1.6
 DN 100; P1.5
 DN 125, DN 150; P1.4
 DN 200; P1.1

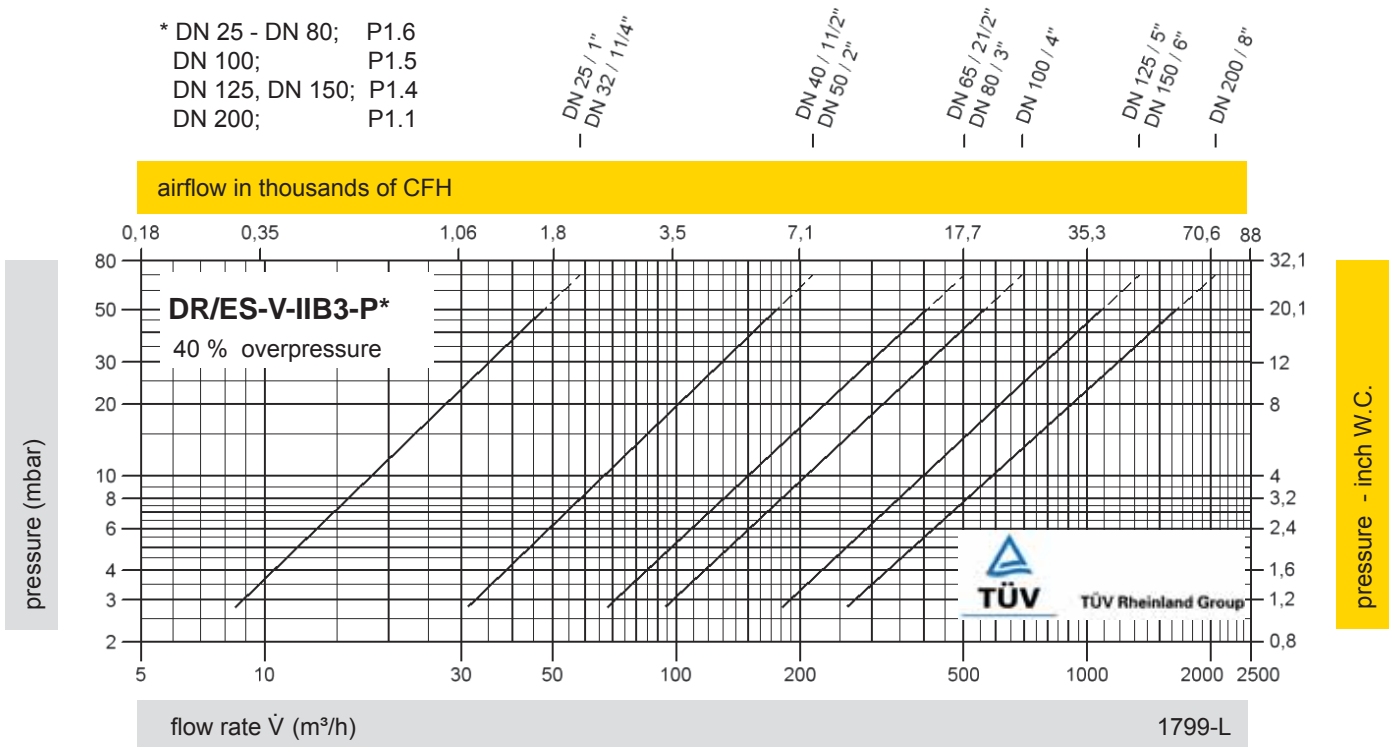



In-Line Liquid Detonation Flame Arrester

for filling lines - external installation

PROTEGO® LDA-W

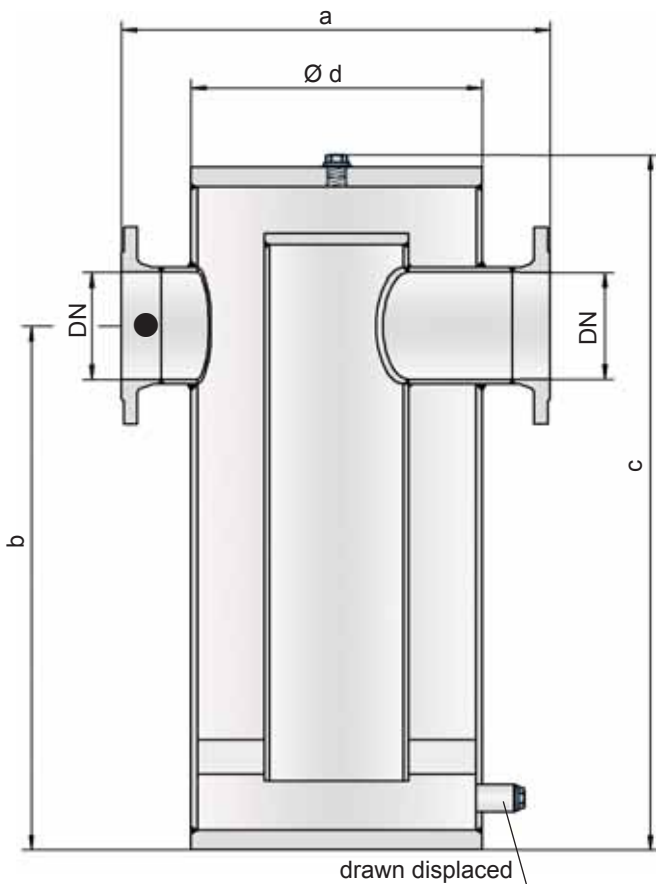

● Tank connection / protected side

Function and Description

The PROTEGO® LDA-W liquid detonation flame arrester was developed for storage container filling lines that are not continuously filled with product and sometimes contain a combustible mixture. The device is installed outside of the container in the filling line. If the explosive atmosphere is ignited, the device prevents the combustion from traveling into the tank. The PROTEGO® LDA-W series of liquid detonation flame arresters functions according to the siphon principle in which the liquid product serves as a barrier against flame propagation.

When a highly accelerated pipe deflagration or detonation occurs, the combustion pressure and flame propagation speed is first substantially reduced by the construction and converted into a low-energy deflagration that is then stopped by the remaining immersion liquid.

The application range for the device is a product vapour/air mixture temperature up to +60°C / 140°F and an absolute pressure up to 1.1 bar / 15.9 psi. This covers all of the possible operating conditions of empty lines for flammable liquids. The liquid detonation arrester is designed for pressures up to 10 bar / 145 psi and therefore resists explosion pressure offering protection for almost all flammable liquids. The device is approved for explosion groups IIA to IIB3 (NEC group D to C MESH ≥ 0.65 mm). Special designs with a cleaning cover for highly viscous and contaminated liquids can be provided.

Type-approved according to ATEX Directive 94/9/EC and EN ISO 16852 as well as other international standards.

Special Features and Advantages

- the device is easily accessible since it is mounted on the containers outside
- minimum risk of soiling
- low pressure loss
- provides protection from deflagrations and stable detonations
- useful for nearly all flammable liquids
- meets TRbF* requirements
- maintenance friendly design also useable as strainer

*TRbF = technical regulations for flammable liquids

Table 1: Dimensions

Dimensions in mm / inches

To select the nominal size (DN), please use the flow capacity chart on the following pages

DN	25 1"	32 1 ¼"	40 1 ½"	50 2"	65 2 ½"	80 3"	100 4"	125 5"	150 6"	200 8"	250 10"	300 12"
a	250 / 9.84	275 / 10.83	350 / 13.78	350 / 13.78	450 / 17.72	450 / 17.72	500 / 19.69	600 / 23.62	600 / 23.62	700 / 27.56	850 / 33.46	1000 / 39.37
b	325 / 12.80	360 / 14.17	420 / 16.54	420 / 16.54	540 / 21.26	540 / 21.26	595 / 23.43	915 / 36.02	915 / 36.02	1100 / 43.31	1325 / 52.17	1480 / 58.27
c	445 / 17.52	480 / 18.90	565 / 22.24	565 / 22.24	720 / 28.35	720 / 28.35	800 / 31.50	1265 / 49.80	1265 / 49.80	1520 / 59.84	1830 / 72.05	2050 / 80.71
d	140 / 5.51	140 / 5.51	195 / 7.68	195 / 7.68	275 / 10.83	275 / 10.83	325 / 12.80	460 / 18.11	460 / 18.11	510 / 20.08	610 / 24.02	700 / 27.56

Table 2: Selection of the explosion group

MESG	Expl. Gr. (IEC/CEN)	Gas Group (NEC)	Special approvals upon request
> 0,90 mm	IIA	D	
≥ 0,65 mm	IIB3	C	

Table 3: Specification of max. operating temperature

≤ 60°C / 140°F	higher operating temperatures upon request
T60	Tmaximum allowable operating temperature in °C

Table 4: Material selection for housing

Design	A	B	C	Special materials upon request
Housing	Steel	Stainless Steel	Hastelloy	
Gasket	PTFE	PTFE	PTFE	

Table 5: Flange connection type

EN 1092-1, Form B1 or DIN 2501, Form C, PN 16; from DN 200 PN 10	EN or DIN	other connections upon request
ANSI 150 lbs RFSF	ANSI	

Flow Capacity Chart

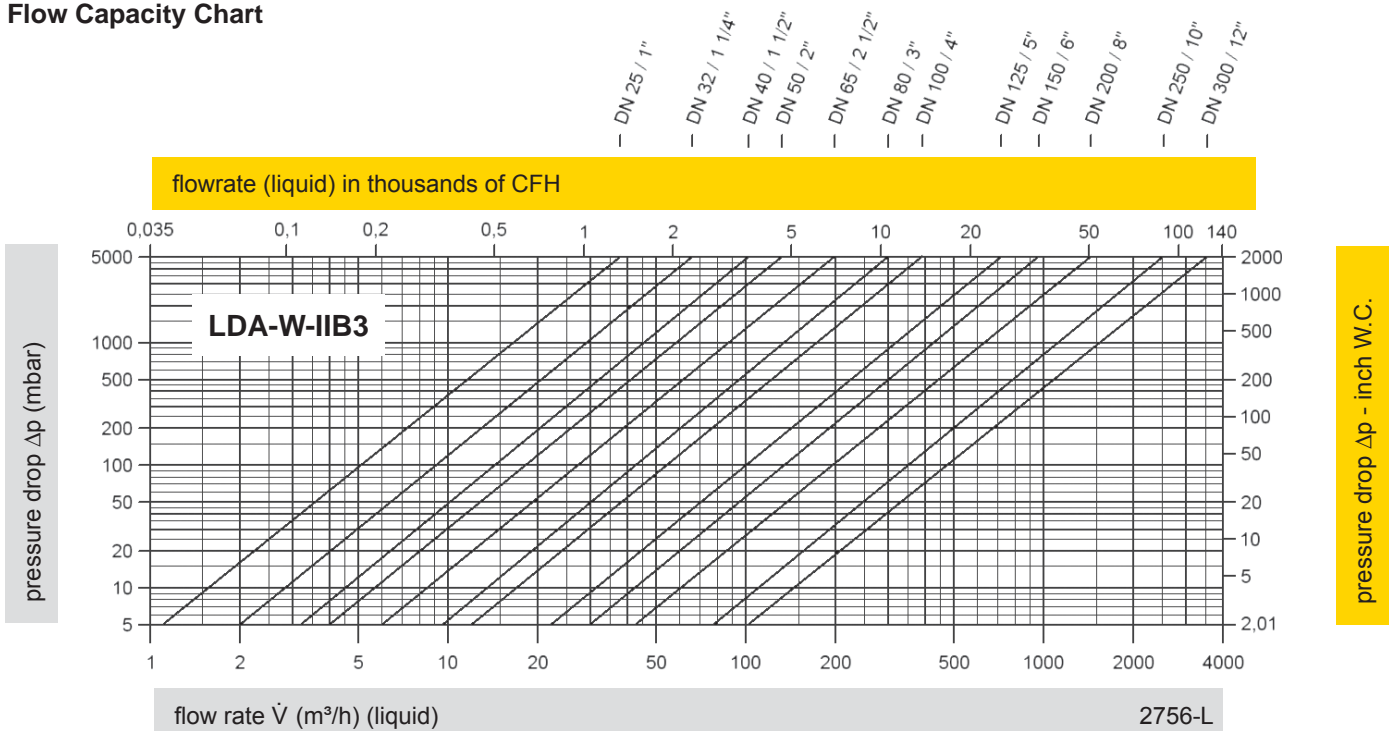

Conversion: $\dot{V}_{liquid} = \dot{V}_{water} * \sqrt{\frac{\rho_{water}}{\rho_{liquid}}}$

The volume flow \dot{V} in m³/h was determined with water according to DIN EN 60534 at a temperature $T_n = 15^\circ\text{C}$ and an atmospheric pressure $p_n = 1,013 \text{ bar}$, kinematic viscosity $\nu = 10^{-6} \text{ m}^2/\text{s}$.

To avoid electrostatic charge of flammable liquids the maximum flow is limited (refer to BG-Regulation 132, CENELEC-Report CLC/TR 50404).



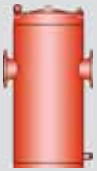

In-Line Liquid Detonation Flame Arrester

for filling and drain lines - external installation

PROTEGO® LDA-WF(W)

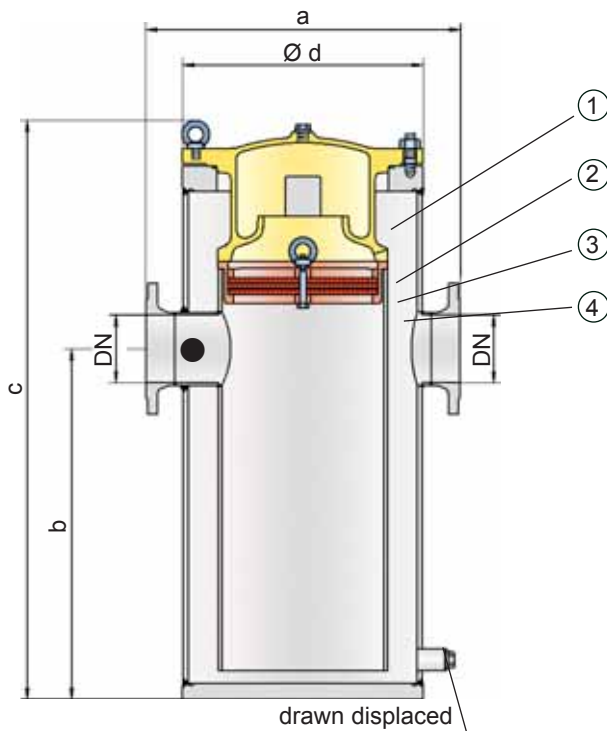

● Tank connection / protected side

Function and Description

The PROTEGO® LDA-WF(W) series of liquid detonation flame arresters was developed for storage container filling lines that are not continuously filled with product and sometimes contain a combustible mixture. The integrated siphon protection (1) with PROTEGO® flame arrester unit (2) additionally prevents the liquid in which the lines are immersed from being siphoned off while the container is being drained. PROTEGO® flame arrester consists of several FLAMEFILTER® discs (3) and spacers firmly held in a FLAMEFILTER® cage (4). The number of FLAMEFILTER® discs and their gap size depends on the arresters conditions of use. The device is installed outside of the container in the filling and drain lines. If the explosive atmo-

sphere is ignited, the device prevents the combustion from traveling into the tank. The PROTEGO® LDA-WF(W) series of liquid detonation flame arresters combines the classic PROTEGO® flame arrester design with the siphon principle in which the liquid product serves as a barrier to flame propagation.

When a highly accelerated pipe deflagration or detonation occurs, the combustion pressure and flame propagation speed is first substantially reduced by the design and converted into a low-energy deflagration that is then stopped by the remaining immersion liquid and the PROTEGO® flame arrester.

The application range for the device is a product vapour/air mixture temperature up to +60°C / 140°F and an absolute pressure up to 1.1 bar / 15.9 psi. This covers all of the possible operating conditions of empty lines for flammable liquids. The liquid detonation arrester is designed for pressures up to 10 bar / 145 psi and therefore resists explosion pressure and offers protection for almost all flammable liquids. The device is approved for explosion groups IIA to IIB3 (NEC group D to C MESH ≥ 0.65 mm). Special designs with a cleaning cover for highly viscous liquids can be provided.

Type-approved according to ATEX Directive 94/9/EC and EN ISO 16852 as well as other international standards.

Special Features and Advantages

- the device is easily accessible since it is mounted on the containers outside
- siphon protection offers a high degree of safety
- minimum risk of soiling
- low pressure loss
- provides protection from deflagrations and stable detonations
- useful for nearly all flammable liquids
- meets TRbF* requirements

*TRbF = technical regulations for flammable liquids

Table 1: Dimensions

Dimensions in mm / inches

To select the nominal size (DN), please use the flow capacity chart on the following pages

DN	25 1"	32 1 ¼"	40 1 ½"	50 2"	65 2 ½"	80 3"	100 4"	125 5"	150 6"	200 8"	250 10"
a	250 / 9.84	250 / 9.84	346 / 13.62	350 / 13.78	446 / 17.56	450 / 17.72	500 / 19.69	600 / 23.62	600 / 23.62	700 / 27.56	900 / 35.43
b	325 / 12.80	325 / 12.80	415 / 16.34	415 / 16.34	535 / 21.06	535 / 21.06	600 / 23.62	915 / 36.02	915 / 36.02	1090 / 42.91	1300 / 51.18
c	475 / 18.70	475 / 18.70	605 / 23.82	605 / 23.82	831 / 32.72	831 / 32.72	936 / 36.58	1340 / 52.76	1340 / 52.76	1520 / 59.84	1750 / 68.90
d	150 / 5.91	150 / 5.91	210 / 8.27	210 / 8.27	275 / 10.83	275 / 10.83	325 / 12.80	460 / 18.11	460 / 18.11	510 / 20.08	610 / 24.02

Table 2: Selection of the explosion group

MESH	Expl. Gr. (IEC/GEN)	Gas Group (NEC)	Special approvals upon request
> 0,90 mm	IIA	D	
≥ 0,65 mm	IIB3	C	

Table 3: Specification of max. operating temperature

≤ 60°C / 140°F	higher operating temperatures upon request
T60	Tmaximum allowable operating temperature in °C

Table 4: Material selection for housing

Design	A	B	Special materials upon request
Housing	Steel	Stainless Steel	
Shock absorber	Steel	Stainless Steel	
Gasket (shock absorber)	FPM	PTFE	
Gasket (locking screw)	PTFE	PTFE	
Flame arrester unit	A	A	

Table 5: Material for flame arrester unit

Design	A	* the FLAMEFILTER® are also available in the materials Tantalum, Inconel, Copper, etc. when the listed housing and cage materials are used.
FLAMEFILTER® cage	Stainless Steel	
FLAMEFILTER® *	Stainless Steel	
Spacer	Stainless Steel	Special materials upon request.

Table 6: Flange connection type

EN 1092-1, Form B1 or DIN 2501, Form C, PN 16; from DN 200 PN 10	EN or DIN	other connections upon request
ANSI 150 lbs RFSF	ANSI	

Flow Capacity Chart

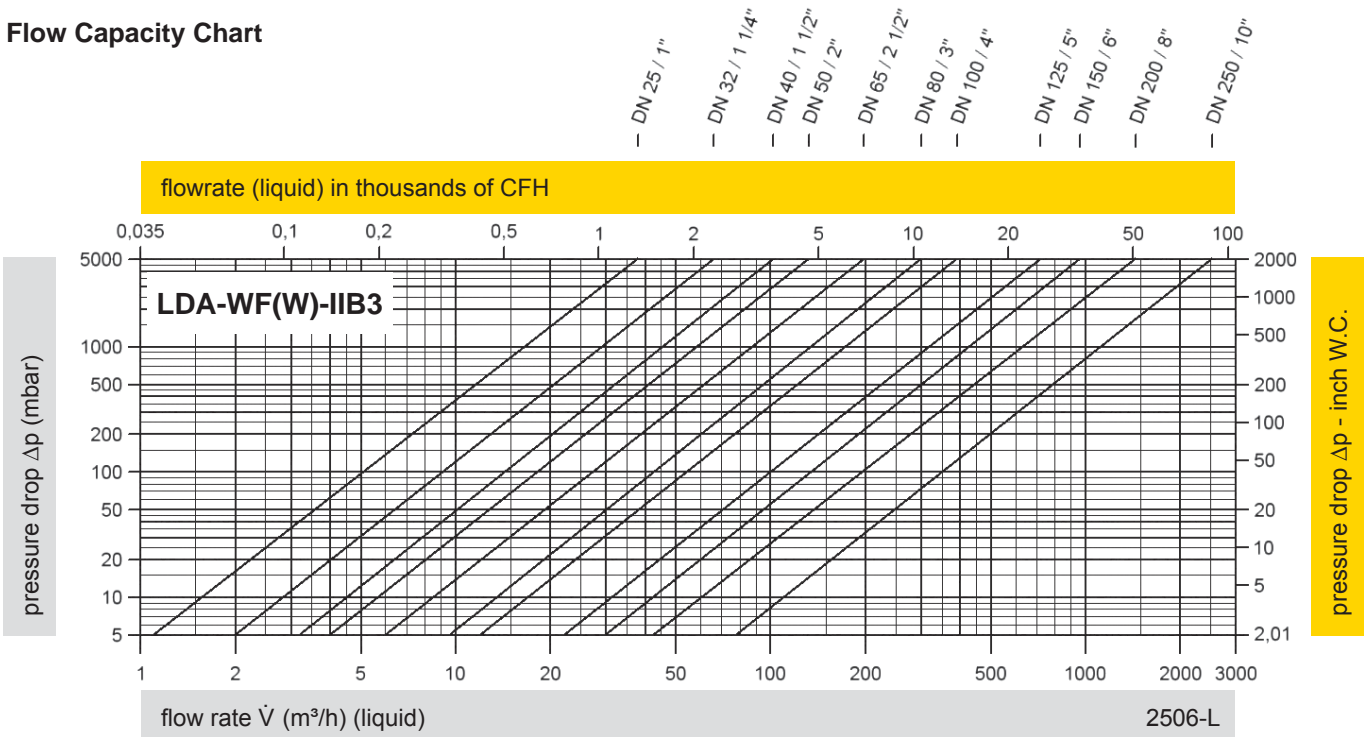

Conversion: $\dot{V}_{liquid} = \dot{V}_{water} * \sqrt{\frac{\rho_{water}}{\rho_{liquid}}}$

The volume flow \dot{V} in m³/h was determined with water according to DIN EN 60534 at a temperature $T_n = 15^\circ\text{C}$ and an atmospheric pressure $p_n = 1,013$ bar, kinematic viscosity $\nu = 10^{-6}$ m²/s. To avoid electrostatic charge of flammable liquids the maximum flow is limited (refer to BG-Regulation 132, CENELEC-Report CLC/TR 50404).





Liquid Detonation Flame Arrester

for filling lines - internal installation

PROTEGO® LDA

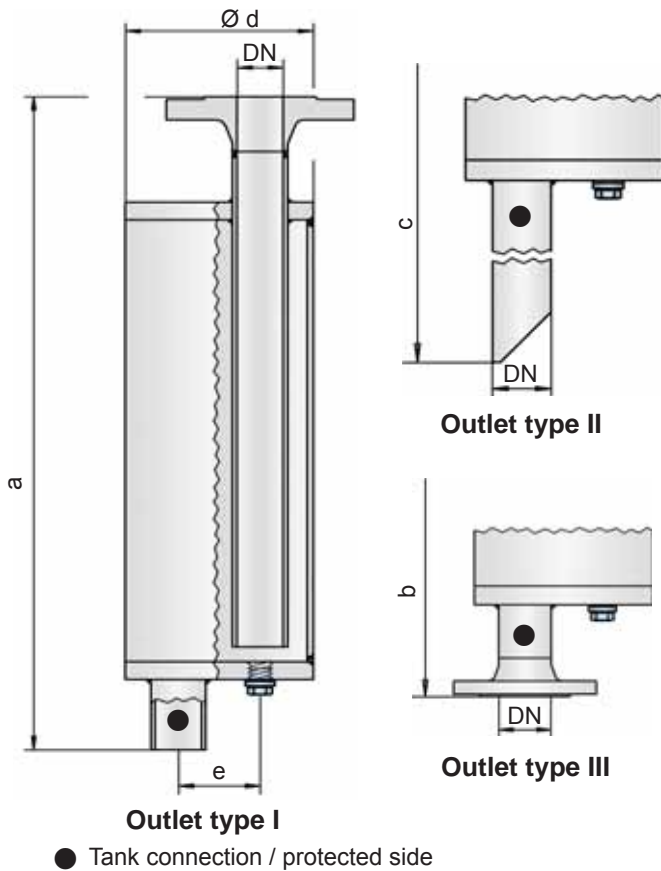

Function and Description

The PROTEGO® LDA series of liquid detonation arresters was developed for storage tank filling lines that are not continuously filled with product and sometimes contain a combustible mixture.

The device is installed inside the tank at the end of the line and prevents the combustion from being transferred into the tank if the explosive atmosphere ignites. The liquid detonation arresters function according to the siphon principle in which the liquid product serves as a liquid barrier to flame propagation.

When a highly accelerated pipe deflagration or detonation occurs, the combustion pressure and flame propagation speed is first substantially reduced by the design and converted into a low-energy deflagration that is then stopped by the remaining immersion liquid.

The application range for the device is a product vapour/air mixture temperature up to + 60°C / 140°F and an absolute pressure up to 1.1 bar / 15.9 psi. This covers all of the possible operating conditions of empty lines for flammable liquids. The liquid detonation arrester is pressure-resistant up to 10 bar / 145 psi. The device protects against nearly all flammable liquids, and is approved for explosion groups IIA to IIB3 (NEC group D to C MESH \geq 0.65 mm). Special designs with a cleaning cover for highly viscous liquids can be provided.

Type-approved according to ATEX Directive 94/9/EC and EN ISO 16852 as well as other international standards.

Special Features and Advantages

- simple construction that helps prevent soiling
- low pressure loss
- provides protection from deflagrations and stable detonations
- useful for nearly all flammable liquids
- meets TRbF* requirements
- deliverable with different outlets

*TRbF = technical regulations for flammable liquids

Table 1: Dimensions

Dimensions in mm / inches

To select the nominal size (DN), please use the flow capacity chart on the following pages

DN	25 1"	32 1 ¼"	40 1 ½"	50 2"	65 2 ½"	80 3"	100 4"	125 5"	150 6"	200 8"	250 10"
a	500 / 19.69	580 / 22.83	700 / 27.56	700 / 27.56	825 / 32.48	925 / 36.42	1050 / 41.34	1150 / 45.28	1350 / 53.15	1650 / 64.96	2000 / 78.74
b	538 / 21.18	620 / 24.41	745 / 29.33	745 / 29.33	870 / 34.25	975 / 38.39	1102 / 43.39	1205 / 47.44	1405 / 55.31	1712 / 67.40	2068 / 81.42
c	725 / 28.54	805 / 31.69	925 / 36.42	925 / 36.42	1050 / 41.34	1145 / 45.08	1270 / 50.00	1380 / 54.33	1580 / 62.20	1880 / 74.02	2300 / 90.55
d	115 / 4.53	140 / 5.51	168 / 6.61	168 / 6.61	220 / 8.66	245 / 9.65	325 / 12.80	356 / 14.02	500 / 19.69	600 / 23.62	700 / 27.56
e	50 / 1.97	58 / 2.28	65 / 2.56	65 / 2.56	95 / 3.74	105 / 4.13	135 / 5.31	155 / 6.10	200 / 7.87	250 / 9.84	300 / 11.81

Table 2: Selection of the explosion group

MESG	Expl. Gr. (IEC/CEN)	Gas Group (NEC)	Special approvals upon request
> 0,90 mm	IIA	D	
≥ 0,65 mm	IIB3	C	

Table 3: Specification of max. operating temperature

≤ 60°C / 140°F	higher operating temperatures upon request
T60	Tmaximum allowable operating temperature in °C

Table 4: Material selection for housing

Design	A	B	Special materials upon request
Housing	Steel	Stainless Steel	
Gasket	PTFE	PTFE	

Table 5: Flange connection type

EN 1092-1, Form B1 or DIN 2501, Form C, PN 16; from DN 200 PN 10	EN or DIN	other connections upon request
ANSI 150 lbs RFSF	ANSI	

Table 6: Outlet type

Straight pipe	I	other types upon request
Beveled pipe	II	
EN 1092-1, Form B1 or DIN 2501, Form C	III (EN or DIN)	
ANSI 150 lbs RFSF	III (ANSI)	

Flow Capacity Chart

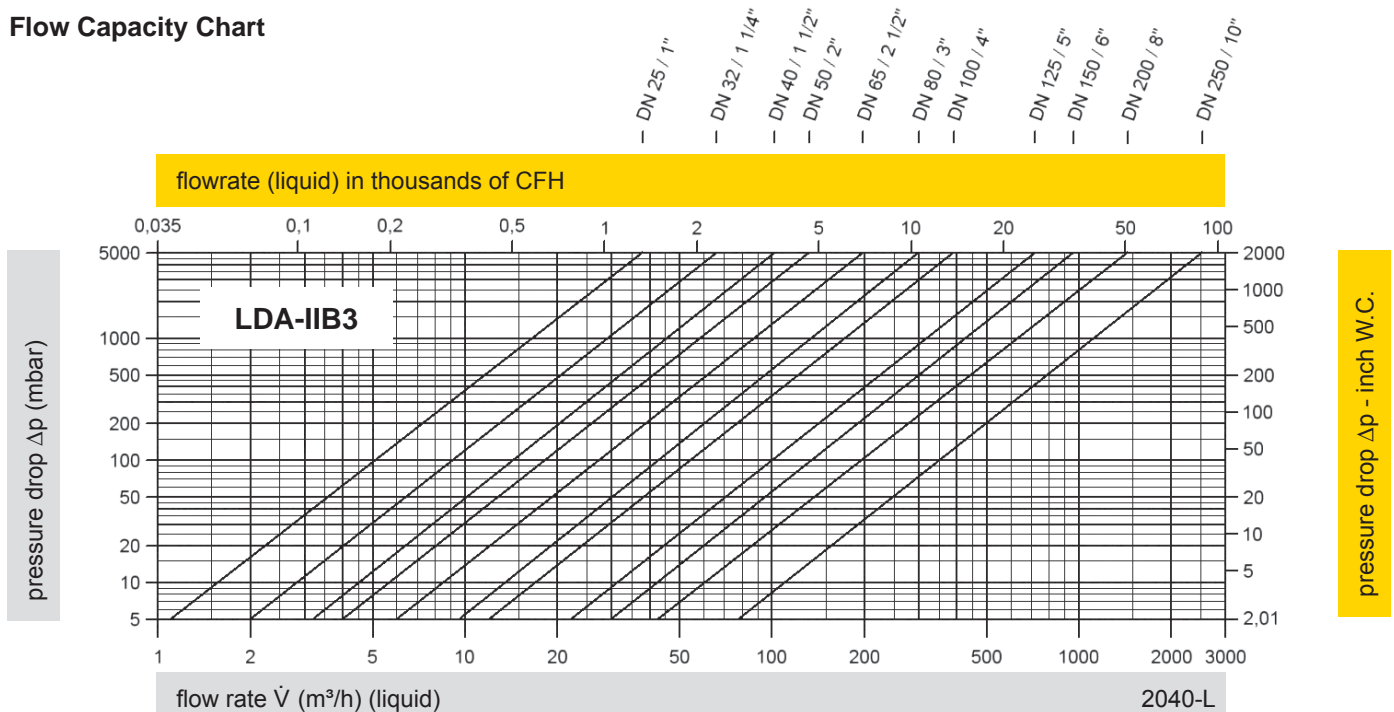

$$\text{Conversion: } \dot{V}_{\text{liquid}} = \dot{V}_{\text{water}} * \sqrt{\frac{\rho_{\text{water}}}{\rho_{\text{liquid}}}}$$

The volume flow \dot{V} in m³/h was determined with water according to DIN EN 60534 at a temperature $T_n = 15^\circ\text{C}$ and an atmospheric pressure $p_n = 1,013$ bar, kinematic viscosity $\nu = 10^{-6}$ m²/s. To avoid electrostatic charge of flammable liquids the maximum flow is limited (refer to BG-Regulation 132, CENELEC-Report CLC/TR 50404).





Liquid Detonation Flame Arrester

for filling and drain lines - internal installation

PROTEGO® LDA-F

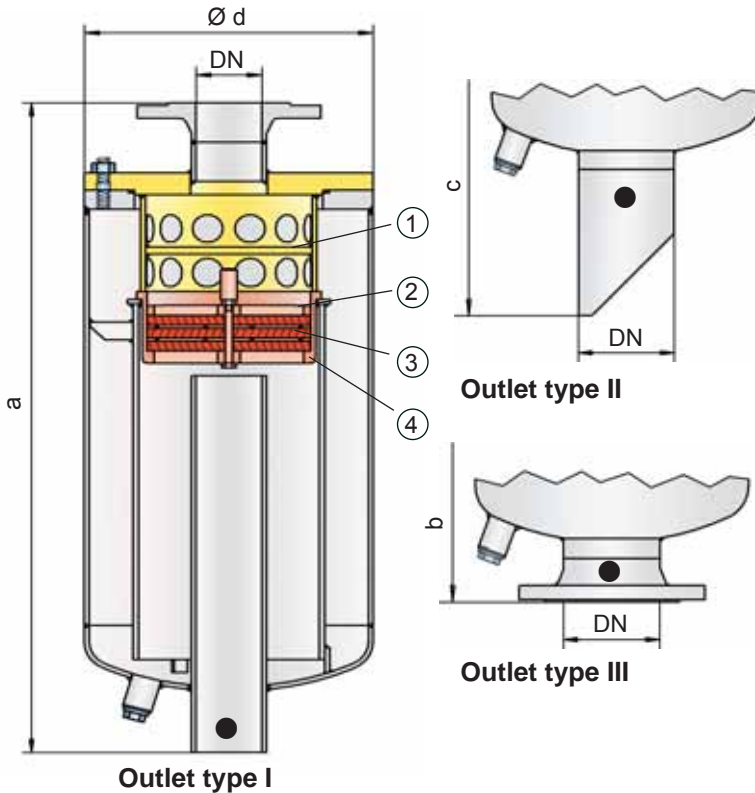

● Tank connection / protected side

conditions of use. The device is installed inside the container at the end of the line and prevents the combustion from being transferred into the tank if the explosive atmosphere ignites. The PROTEGO® LDA-F series of liquid detonation arresters combines the classic PROTEGO® flame arrester design with the siphon principle in which the liquid product serves as a barrier to flame propagation.

When a highly accelerated pipe deflagration or detonation occurs, the combustion pressure and flame propagation speed is first substantially reduced by the design and converted into a low-energy deflagration that is then stopped by the remaining immersion liquid and the PROTEGO® flame arrester.

The application limits for the device is product vapour/air mixture temperatures up to +60°C / 140°F and an absolute pressure up to 1.1 bar / 15.9 psi. This covers all of the possible operating conditions of empty lines for flammable liquids. The liquid detonation arrester in standard design is pressure-resistant up to 10 bar / 145 psi. The device protects against nearly all flammable liquids and is approved for explosion groups IIA to IIB3 (NEC group D and C MESH ≥ 0.65 mm).

Type-approved according to ATEX Directive 94/9/EC and EN ISO 16852 as well as other international standards.

Function and Description

The PROTEGO® LDA-F series of liquid detonation arresters was developed for storage tanks filling and drain lines that are not continuously filled with product and sometimes contain a combustible mixture. The integrated siphon protection (1) with PROTEGO® flame arrester unit (2) additionally prevents the liquid in which the lines are immersed from being siphoned off while the container is being drained. The PROTEGO® flame arrester consists of several FLAMEFILTER® discs (3) and spacers firmly held in a FLAMEFILTER® cage (4). The number of FLAMEFILTER® discs and their gap size depends on the arresters

Special Features and Advantages

- siphon protection offers a high degree of safety
- minimum risk of soiling
- low pressure loss
- provides protection from deflagrations and stable detonations
- useful for nearly all flammable liquids
- meets TRbF* requirements
- deliverable with different outlets

*TRbF = technical regulations for flammable liquids

Table 1: Dimensions

Dimensions in mm / inches

To select the nominal size (DN), please use the flow capacity chart on the following pages

DN	25 1"	32 1 ¼"	40 1 ½"	50 2"	65 2 ½"	80 3"	100 4"	125 5"	150 6"	200 8"	250 10"
a	550 / 21.65	550 / 21.65	650 / 25.59	650 / 25.59	850 / 33.46	875 / 34.45	1050 / 41.34	1250 / 49.21	1450 / 57.09	1600 / 62.99	1975 / 77.76
b	588 / 23.15	590 / 23.23	692 / 27.24	695 / 27.36	895 / 35.24	925 / 36.42	1102 / 43.39	1305 / 51.38	1505 / 59.25	1662 / 65.43	2043 / 80.43
c	775 / 30.51	775 / 30.51	875 / 34.45	875 / 34.45	1075 / 42.32	1095 / 43.11	1270 / 50.00	1480 / 58.27	1680 / 66.14	1830 / 72.05	2275 / 89.57
d	140 / 5.51	140 / 5.51	220 / 8.66	220 / 8.66	275 / 10.83	275 / 10.83	356 / 14.07	457 / 17.99	508 / 20.00	600 / 23.62	711 / 27.99

Table 2: Selection of the explosion group

MESH	Expl. Gr. (IEC/CEN)	Gas Group (NEC)	Special approvals upon request
> 0,90 mm	IIA	D	
≥ 0,65 mm	IIB3	C	

Table 3: Specification of max. operating temperature

≤ 60°C / 140°F	higher operating temperatures upon request
T60	Tmaximum allowable operating temperature in °C

Table 4: Material selection for housing

Design	A	B	Special materials upon request
Housing	Steel	Stainless Steel	
Shock absorber	Steel	Stainless Steel	
Gasket	FPM	PTFE	
Flame arrester unit	A	A	

Table 5: Material for flame arrester unit

Design	A	* the FLAMEFILTER® are also available in the materials Tantalum, Inconel, Copper, etc. when the listed housing and cage materials are used.
FLAMEFILTER® cage	Stainless Steel	
FLAMEFILTER® *	Stainless Steel	
Spacer	Stainless Steel	Special materials upon request

Table 6: Flange connection type

EN 1092-1, Form B1 or DIN 2501, Form C, PN 16; from DN 200 PN 10	EN or DIN	other connections upon request
ANSI 150 lbs RFSF	ANSI	

Table 7: Outlet type

Straight pipe	I	other types upon request
Beveled pipe	II	
EN 1092-1, Form B1 or DIN 2501, Form C	III (EN or DIN)	
ANSI 150 lbs RFSF	III (ANSI)	

Flow Capacity Chart

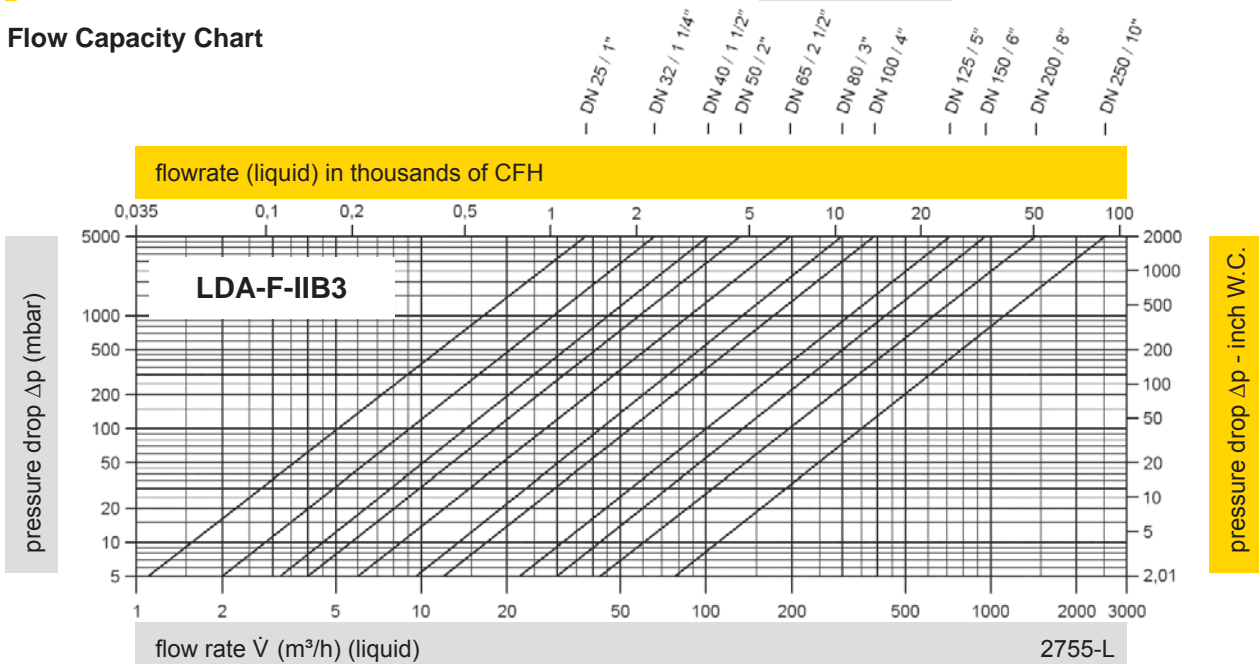

Conversion: $\dot{V}_{liquid} = \dot{V}_{water} * \sqrt{\frac{\rho_{water}}{\rho_{liquid}}}$

The volume flow \dot{V} in m³/h was determined with water according to DIN EN 60534 at a temperature $T_n = 15^\circ\text{C}$ and an atmospheric pressure $p_n = 1,013$ bar, kinematic viscosity $\nu = 10^{-6}$ m²/s. To avoid electrostatic charge of flammable liquids the maximum flow is limited (refer to BG-Regulation 132, CENELEC-Report CLC/TR 50404).





Detonation Flame Arrester

Detonation-proof foot valve for suction lines

PROTEGO® EF/V-IIB3

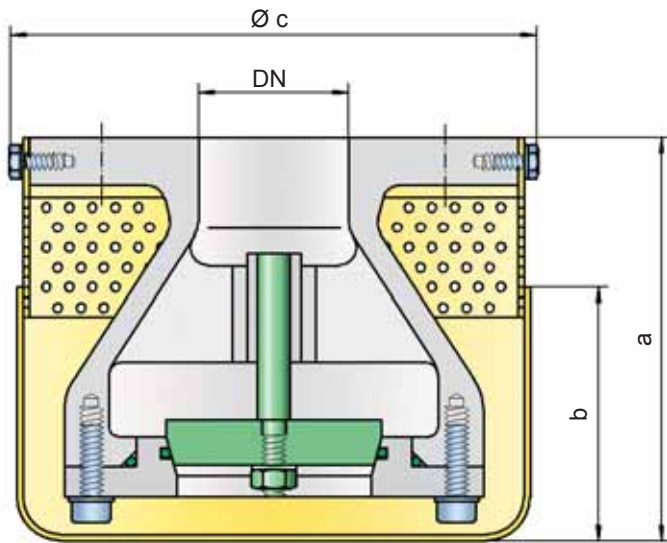

Combustible mixtures can arise in filling and drain lines of storage containers that are not always filled with product. With the ignition of the explosive atmosphere, highly accelerated pipe deflagration or detonations can arise. The detonation-proof foot valve prevents the combustion from being transmitted into the tank and destroying it. The design of the foot valve ensures that the strainer is always filled with residual product. Together with the special valve design, this combination prevents flame flash back from the inside out.

The application limits for the device are a product vapour/air mixture temperature up to +60°C / 140°F and an absolute pressure up to 1.1 bar / 15.9 psi. This covers all of the possible operating conditions of empty lines for flammable liquids.

The device protects against nearly all flammable liquids, and is permitted for explosion group IIB3 (C MESG ≥ 0.65 mm).

Type-approved according to ATEX Directive 94/9/EC and EN ISO 16852 as well as other international standards.

Function and Description

The PROTEGO® EF/V-IIB3 detonation-safe foot valve protects the suction line in a storage tank. The nearly service-free device is installed at the end of the emptying line within the tank. When a pump draws, the valve opens at an approximate underpressure of 30 mbar / 12 inch W.C. . When the pump is turned off, the device functions as a check valve and prevents the line from emptying. This is very helpful when the pump is restarted.

Special Features and Advantages

- almost service-free
- the check valve makes it easier to start the pump
- provides protection from deflagrations and stable detonations
- applicable to nearly all flammable liquids
- meets TRbF* 20 requirements
- the special strainer prevents solid particles from entering

*TRbF = technical regulations for flammable liquids

Table 1: Dimensions

Dimensions in mm / inches

To select the nominal size (DN), please use the flow capacity chart on the following page

DN	25 1"	32 1 ¼"	40 1 ½"	50 2"	65 2 ½"	80 3"	100 4"	125 5"	150 6"	200 8"	250 10"
a	125 / 4.92	125 / 4.92	135 / 5.31	135 / 5.31	160 / 6.29	160 / 6.29	200 / 7.87	235 / 9.25	260 / 10.24	400 / 15.75	450 / 17.72
b	85 / 3.35	85 / 3.35	85 / 3.35	85 / 3.35	95 / 3.74	95 / 3.74	125 / 4.92	130 / 5.12	135 / 5.31	175 / 6.89	200 / 7.81
c	155 / 6.10	155 / 6.10	180 / 7.09	180 / 7.09	210 / 8.27	210 / 8.27	250 / 9.84	310 / 12.20	365 / 14.37	480 / 18.90	565 / 22.24

Table 2: Selection of the explosion group

MESG	Expl. Gr. (IEC/CEN)	Gas Group (NEC)	Special approvals upon request
≥ 0,65 mm	IIB3	C	

Table 3: Specification of max. operating temperature

≤ 60°C / 140°F	higher operating temperatures upon request
T60	Tmaximum allowable operating temperature in °C

Table 4: Material selection for housing

Design	A	B	C	D	Special materials upon request
Housing	Steel	Stainless Steel	Steel	Stainless Steel	
Valve	Stainless Steel	Stainless Steel	Stainless Steel	Stainless Steel	
Gasket (Valve)	PTFE	PTFE	PTFE	PTFE	
Gasket (Housing)	FPM	FPM	PTFE	PTFE	
Strainer	Stainless Steel	Stainless Steel	Stainless Steel	Stainless Steel	

Table 7: Flange connection type

EN 1092-1, Form A or DIN 2501, Form B, PN 16; from DN 200 PN 10	EN or DIN	other connections upon request
ANSI 150 lbs RFSF	ANSI	

Flow Capacity Chart

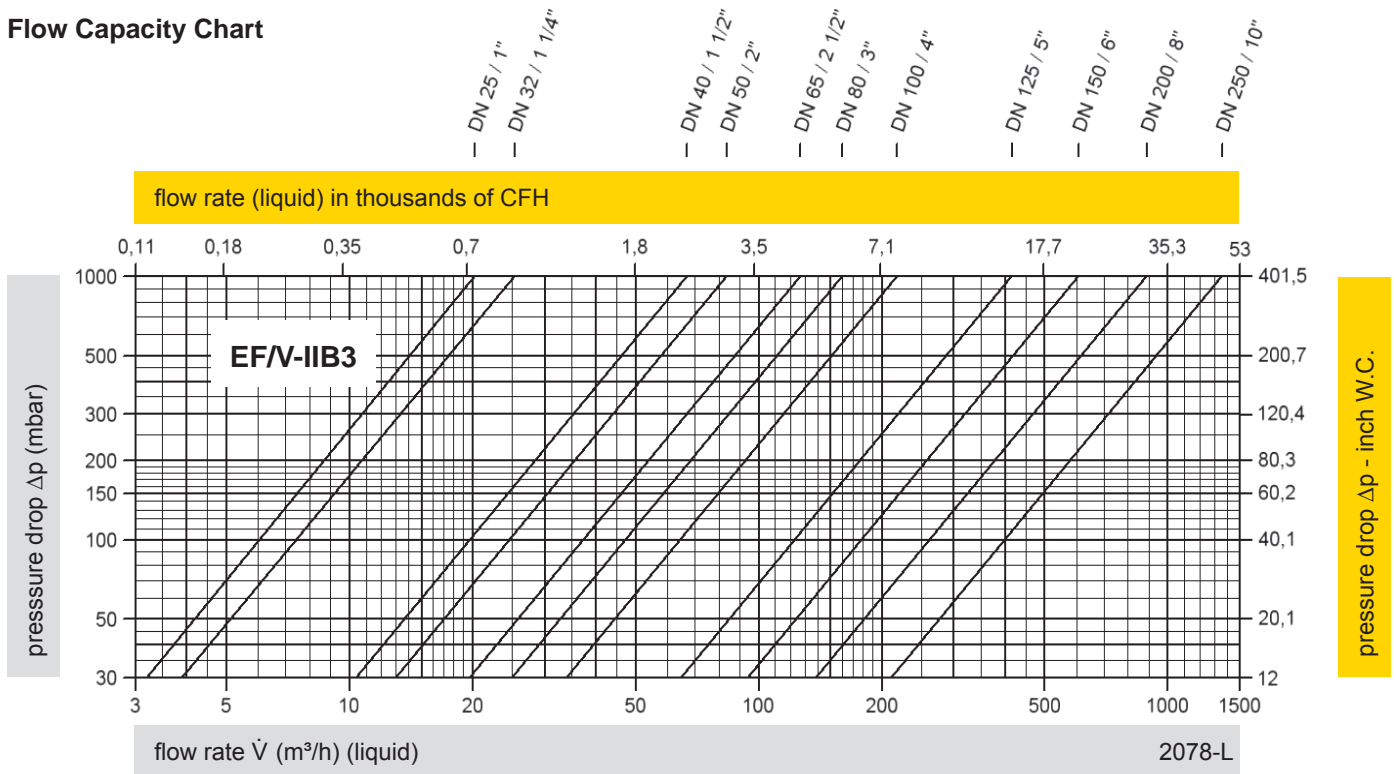

$$\text{Conversion: } \dot{V}_{\text{liquid}} = \dot{V}_{\text{water}} * \sqrt{\frac{\rho_{\text{water}}}{\rho_{\text{liquid}}}}$$

The volume flow \dot{V} in m³/h was determined with water according to DIN EN 60534 at a temperature $T_n = 15^\circ\text{C}$ and an atmospheric pressure $p_n = 1,013 \text{ bar}$, kinematic viscosity $\nu = 10^{-6} \text{ m}^2/\text{s}$. To avoid electrostatic charge of flammable liquids the maximum flow is limited (refer to BG-Regulation 132, CENELEC-Report CLC/TR 50404).





Hydraulic Flame Arresters

deflagration proof, detonation proof and short-time burning proof

PROTEGO® TS/P, TS/E and TS/W

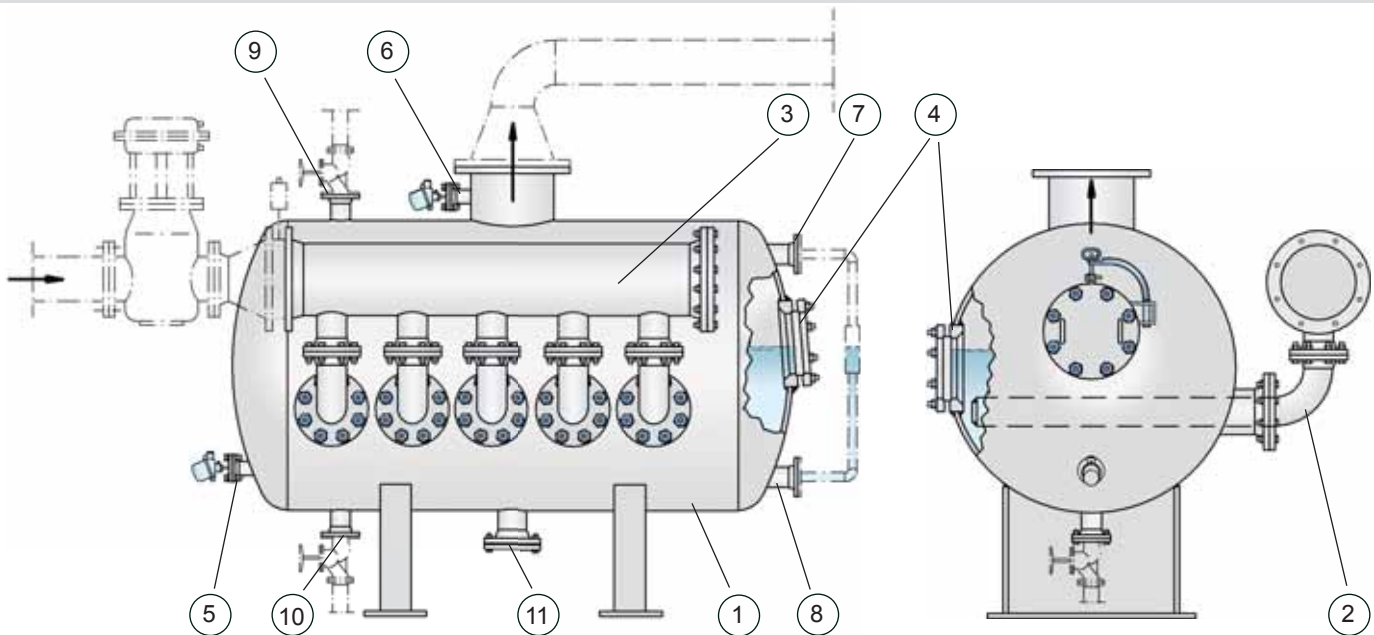

Function and Description

The PROTEGO® hydraulic flame arresters of type TS/... are mainly designed to protect process plants which are connected to waste thermal combustion units. Hydraulic flame arresters of the TS/... series are particularly suitable to protect plants which supply heavily contaminated, sticking, polymerizing or even foaming substances into thermal combustion units. Generally it is necessary to protect the plant against in-line deflagration, stable detonation and endurance burning hazards taking into account the plant's operating conditions.

The PROTEGO® TS/... series of hydraulic flame arresters guarantees flame transmission protection during short time burning, deflagration and stable detonation of gas/air mixtures or product vapour/air mixtures of the relevant explosion groups in all ranges of flammable concentrations up to a service temperature of +60 °C / 140 °F and under an operating pressure up to 1.1 bar / 15 psi (absolute).

Flame arresters of type TS/... are the only hydraulic flame arresters which have been tested and certified for substances of all explosion groups.

Type-approved according to ATEX Directive 94/9/EC and EN ISO 16852 as well as other international standards.

Hydraulic flame arresters of series TS/... mainly consist of the immersion tank (1) with off gas nozzle and connection nozzles for the sparge pipes, the sparge pipes (2) with elbows and connection flanges as well as the manifolds (3) with connection flanges. To allow measurement of the immersion liquid temperature the tank (1) has a minimum of one nozzle (5), and for measuring the temperature of the off gas there is a minimum of one connection for each exhaust gas nozzle (6) for insertion of temperature sensors. Additionally the tank has two nozzles (7, 8) for level measurement, two nozzles (9, 10) for level control, and one nozzle (11) for draining. Inspection-glasses (4) are included for inspection of the immersion liquid and gas space. The sparge pipes can be pulled out of the hydraulic flame

arrester to allow cleaning of the drill holes and the pipes. At the off gas inlet the manifold has the required flange connection and the relevant number of nozzles for distributing the off gas into required number of sparge pipes.

In PROTEGO® hydraulic flame arresters of type TS/... the flammable mixtures are passed through a water seal with a defined immersion depth. The mixture flow is prorated up and passed to the individual sparge pipes. The sparge pipes have small drill holes and therefore produce defined bubble columns. In case of an ignition in the flowing gas mixture the flame is prevented from transmission into the inlet line. The following parameters have a significant effect on the flame arresting efficiency of the device in case of deflagrations, detonations or short time burning:

- Mixture volume flow,
- Immersion depth from the water seal's surface to the upper edges of the drill holes in the sparge pipes,
- Water temperature in the hydraulic flame arrester
- Sizes, form and density of the bubbles and therefore the precise drill hole diameter in the sparge pipes.

If the mixture ignites under certain operating conditions within the hydraulic flame arrester and burns directly on the liquid surface prevention of flame transmission can only be guaranteed for a limited amount of time. Therefore a number of temperature sensors are installed in the gas space and when reaching a specified temperature they trigger appropriate emergency functions upstream in the system connected (shut down, inerting, etc.).

A high accuracy volume flow meter must be installed as an essential technical safety element. It has to guarantee that the maximum allowable volume flow, on which the design of the hydraulic flame arrester has been based, is recorded and limited so that emergency functions are triggered if the off gas volumes exceed the safe level. In addition, a minimum flame-transmission-proof immersion height is necessary, i.e. an

adequate water level must be guaranteed by suitable measuring equipment.

The pressure loss of a hydraulic flame arrester at maximum volume flow equals losses at inflow and outflow of approximately 12 to 18 mbar / 4.8 to 7.2 In W.C. plus the immersion depth, e.g. 350 mm = 35 mbar / 13.8 In = 14.1 In W.C., so the total is between 47 and 53 mbar / 18.9 and 21.3 In W.C.

Instrumentation

The efficiency and function of the PROTEGO TS/... hydraulic flame arrester requires measurement and control equipment for the filling level, volume flow and temperature of the system. It is necessary to maintain the minimum operating immersion depth and measure the maximum mixture volume flow, maximum gas temperature and minimum water temperature. If the safe operational envelope is exceeded, the measurement and control equipment must quickly initiate automatic emergency functions. Measurement and control safety equipment must be explosion proof and approved for zone 0.

Measurement and control equipment is not part of standard scope of supply.

Maximum Volume Flow

The maximum allowable operating volume flow is calculated by multiplying the number of sparge pipes by the maximum allowable operating volume flow for each sparge pipe at its immersion depth.

In special cases it may not be necessary to measure the volume flow provided that the volume flow limitation is guaranteed by other components in the system such as a conveyor system or a choke in combination with a decompression device.

Level Measurement and Level Control

The operating immersion depth should be kept constant by a controlled automatic water supply so that the level does not fall below the minimum immersion depth.

Temperature Measurement and Limitation

In order to prevent endurance burning in the arrester the off gas supply must be stopped automatically when the temperature exceeds $T = 80^{\circ}\text{C} / 176^{\circ}\text{F}$ at the gas outlet. Temperature sensors monitor the mixture temperature.

If the water temperature falls below $T < 10^{\circ}\text{C} / 50^{\circ}\text{F}$ (danger of freezing) or rises above the limiting temperature in the gas space, a quick action gate valve must shut automatically and stop the off gas supply.

As an option temperature sensors can be supplied.

Design Types and Specifications

The hydraulic flame arresters are designated by explosion groups, diameters and numbers of sparge pipes. They are designed in modules and type tested for the corresponding explosion groups.

For explosion group IIA (NFPA group D)

Types TS/P 1000 / 40" or TS/P 2000 / 80"

For explosion group IIB3 (NFPA group C)
Types TS/E 1000 / 40" or TS/E 2000 / 80"

For explosion group IIC (NFPA group B)
Types TS/W 1000 / 40" or TS/W 2000 / 80"

The number of sparge pipes depends on the design volume flow.

Example: TS/E-1000-5 is a hydraulic flame arrester for substances of explosion group IIB3 (NFPA group C) with a diameter of 1000 mm / 40" and 5 sparge pipes.

Dimensions

Standard diameters of TS/... series hydraulic flame arresters are 1000 mm / 40" and 2000 mm / 80". Alternatively diameters from 600 mm / 24" to 3000 mm / 120" are available depending on the off gas volume flow. Hydraulic flame arresters with diameters from 2000 mm / 80" and larger have a restriction plate to prevent wave motions in the sparging zone. All outlet headers and inlet headers as well as internal are components relevant for technical safety, and it is therefore not allowed to change their design and function nor that of the hydraulic flame arrester!

Material Selection

The material selection is determined by the exhaust air process data. Tank designs of steel, stainless steel, coated steel or steel lined with ECTFE or resin are available depending on the application. The sparge pipes are made of stainless, hastelloy or plastic.

Flange Connection Type

The standard flange connections are made to EN 1092-1 or DIN 2501, PN 16 (from DN 200, PN 10). Optionally, the connecting flanges can be made according to any international standard.

Selection and Design

The static immersion depth and the resistance due to dynamic flow in the sparge pipes and the off gas supply lines create the total pressure loss. The manufacturer's advice about technical safety is absolutely necessary in any case!

For particularly corrosive mixtures the hydraulic flame arrester may be coated. The materials of tank, installations and sparge pipes have to be selected according to the corrosive properties of the mixture.

Data Necessary for Specification

The following operational data is required for the technical safety of the hydraulic flame arrester design:

Off gas volume flow taking into account the maximum possible volume flow (m^3/h or CFH)

Off gas composition (vol.%)

Operating temperature ($^{\circ}\text{C}$ or $^{\circ}\text{F}$)



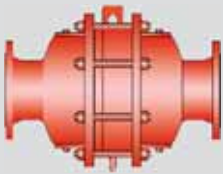

In-Line Detonation Flame Arrester

for unstable and stable detonations and deflagrations in a straight through design with a shock tube, bidirectional

PROTEGO® DA-UB

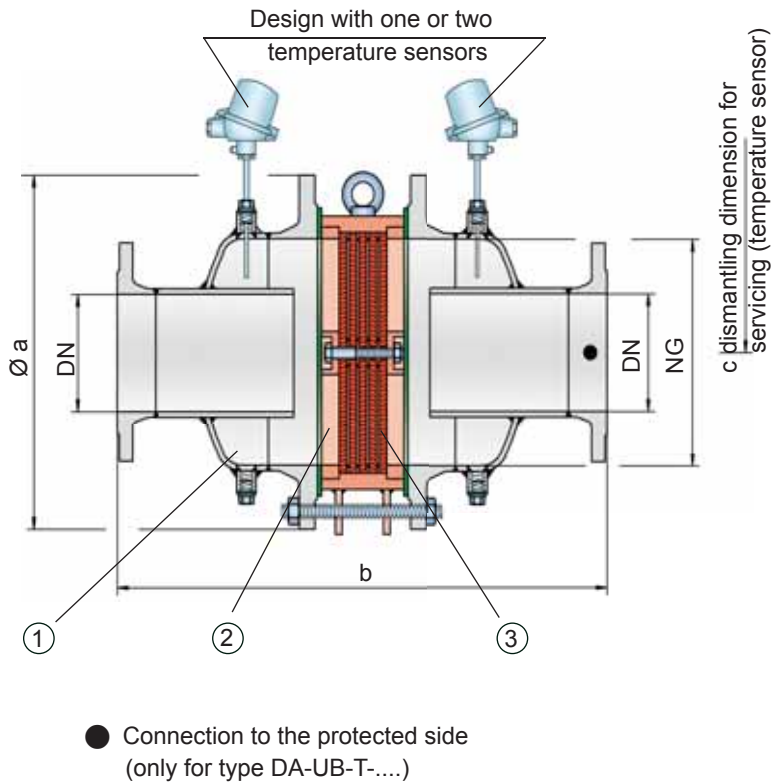

The standard design can be used up to an operating temperature of +60°C / 140°F and an absolute operating pressure up to 1.1 bar / 15.9 psi. Numerous devices with special approval can be supplied for higher pressures (see table 3) and higher temperatures.

Type-approved according to ATEX Directive 94/9/EC und EN ISO 16852 as well as other international standards.

Special Features and Advantages

- optimized performance from the patented *Shock Wave Guide Tube Effect (SWGTE)*
- less number of FLAMEFILTER® discs from the use of the patented shock tube (SWGTE)
- modular flame arrester unit enables each individual FLAMEFILTER® discs to be replaced and cleaned
- different series allow increase of FLAMEFILTER® size for given flange connection resulting in lower pressure drop across the device
- service-friendly design
- expanded application range for higher operating temperatures and pressures
- bidirectional operation as well as any direction of flow and installation position
- possible installation of temperature sensors
- minimum pressure loss and associated low operating and life-cycle cost
- cost efficient spare parts

Function and Description

The in-line detonation flame arresters type PROTEGO® DA-UB are the newest generation of flame arresters. On the basis of fluid dynamic and explosion-dynamic calculations and decades of experience from field tests, a line was developed that offers minimum pressure loss and maximum safety. The device uses the *Shock Wave Guide Tube Effect (SWGTE)* to separate the flame front and shock wave. The result is an in-line detonation flame arrester without a classic shock absorber, and the use of flame-extinguishing elements is minimized.

The devices are symmetrical and offer bidirectional flame arresting for deflagrations, stable and unstable detonations. The arrester essentially consists of two housing parts with an integrated shock tube (1) and the PROTEGO® flame arrester unit (2) in the center. The PROTEGO® flame arrester unit is modular and consists of several FLAMEFILTER® discs (3) and spacers firmly held in a FLAMEFILTER® cage. The number of FLAMEFILTER® discs and their gap size depends on the arrester's conditions of use.

By indicating the operating parameters such as temperature, pressure and explosion group and the composition of the fluid, the optimum detonation arrester can be selected from a series of approved devices. PROTEGO® DA-UB flame arresters are available for explosion groups IIA to IIB3 (NEC group D to C MESH ≥ 0.65 mm).

Design Types and Specifications

There are four different designs available:

Basic in-line detonation flame arrester DA-UB - -

In-line detonation flame arrester with integrated temperature sensor* as additional protection against short time burning DA-UB - T -

In-line detonation flame arrester with two integrated temperature sensors* for additional protection against short time burning from both sides DA-UB - TB -

In-line detonation flame arrester with heating jacket DA-UB - H -

Additional special flame arresters upon request

*Resistance thermometer for device group II, category (1) 2 (GII cat. (1) 2)

Table 1: Dimensions											Dimensions in mm / inches	
To select nominal width/nominal size (NG/DN) - combination, please use the flow capacity charts on the following pages						Additional nominal width/nominal size (NG/DN) - combinations for improved flow capacity upon request						
standard												
NG	150 6"	150 6"	200 8"	300 12"	400 16"	500 20"	600 24"	700 28"	800 32"	1400 56"		
DN	≤ 50 2"	80 3"	≤ 100 4"	≤ 150 6"	≤ 200 8"	≤ 250 10"	≤ 300 12"	≤ 350 14"	≤ 400 16"	≤ 600 24"		
a	285 / 11.22	285 / 11.22	340 / 13.39	445 / 17.52	565 / 22.24	670 / 26.38	780 / 30.71	895 / 35.24	1015 / 39.96	1675 / 65.94		
b	IIA -P1.1				700 / 27.56	800 / 31.50	1000 / 39.37	1200 / 47.24	1400 / 55.12	2200 / 86.61		
	IIA-P1.2	388 / 15.28	388 / 15.28	488 / 19.21	626 / 24.65							
	IIB3-P1.1			500 / 19.69	638 / 25.12	724 / 28.50	824 / 32.44	1000 / 39.37	1200 / 47.24	1400 / 55.12		
	IIB3-P1.2	388 / 15.28	388 / 15.28									
c	500 / 19.69	500 / 19.69	520 / 20.47	570 / 22.44	620 / 24.41	670 / 26.38	720 / 28.35	770 / 30.31	820 / 32.28	1060 / 41.73		

Table 2: Selection of the explosion group			
MESG	Expl. Gr. (IEC/CEN)	Gas Group (NEC)	Special approvals upon request
> 0,90 mm	IIA	D	
≥ 0,65 mm	IIB3	C	

Table 3: Selection of max. operating pressure											
NG		150 6"	150 6"	200 8"	300 12"	400 16"	500 20"	600 24"	700 28"	800 32"	1400 56"
DN		≤ 50 2"	80 3"	≤ 100 4"	≤ 150 6"	≤ 200 8"	≤ 250 10"	≤ 300 12"	≤ 350 14"	≤ 400 16"	≤ 600 24"
Expl. Gr.	IIA	P _{max}	1.8 / 26.1	1.8 / 26.1	1.6 / 23.2	1.6 / 23.2	1.1 / 15.9	1.1 / 15.9	1.1 / 15.9	1.1 / 15.9	1.6 / 23.2
	IIB3	P _{max}	1.5 / 21.7	1.5 / 21.7	1.5 / 21.7	1.5 / 21.7	1.1 / 15.9	1.1 / 15.9	1.1 / 15.9	1.1 / 15.9	1.1 / 15.9

P_{max} = maximum allowable operating pressure in bar / psi (absolute), higher operating pressure upon request
in-between size up to P_{max} upon request

Table 4: Specification of max. operating temperature	
≤ 60°C / 140°F	higher operating temperatures upon request
T60	Tmaximum allowable operating temperature in °C



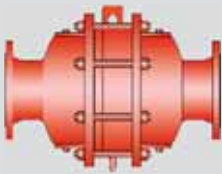

In-Line Detonation Flame Arrester

for unstable and stable detonations and deflagrations in a straight through design with a shock tube, bidirectional

PROTEGO® DA-UB

Table 5: Material selection for housing

Design	A	B	C
Housing	Steel	Stainless Steel	Hastelloy
Heating jacket (DA-UB-(T)-H-...)	Steel	Stainless Steel	Stainless Steel
Gasket	PTFE	PTFE	PTFE
Flame arrester unit	A	B, C	D

The housing is also available in Steel with an ECTFE coating.

Special materials upon request

Table 6: Material combinations of the flame arrester unit

Design	A	B	C	D
FLAMEFILTER® cage	Steel	Stainless Steel	Stainless Steel	Hastelloy
FLAMEFILTER® *	Stainless Steel	Stainless Steel	Hastelloy	Hastelloy
Spacer	Stainless Steel	Stainless Steel	Hastelloy	Hastelloy

*the FLAMEFILTER® are also available in the materials Tantalum, Inconel, Copper, etc. when the listed housing and cage materials are used.

Special materials upon request

Table 7: Flange connection type

EN 1092-1, Form B1 or DIN 2501, Form C, PN 16; from DN 200 PN 10	EN or DIN
ANSI 150 lbs RFSF	ANSI

other types upon request

* P1.2

NG / DN
 150/50 (6" / 2") *
 150/80 (6" / 3") *
 200/100 (8" / 4") *
 300/150 (12" / 6") *
 400/200 (16" / 8")
 500/250 (20" / 10")
 600/300 (24" / 12")
 700/350 (28" / 14")
 800/400 (32" / 16")

airflow in thousands of CFH

pressure drop Δp (mbar)

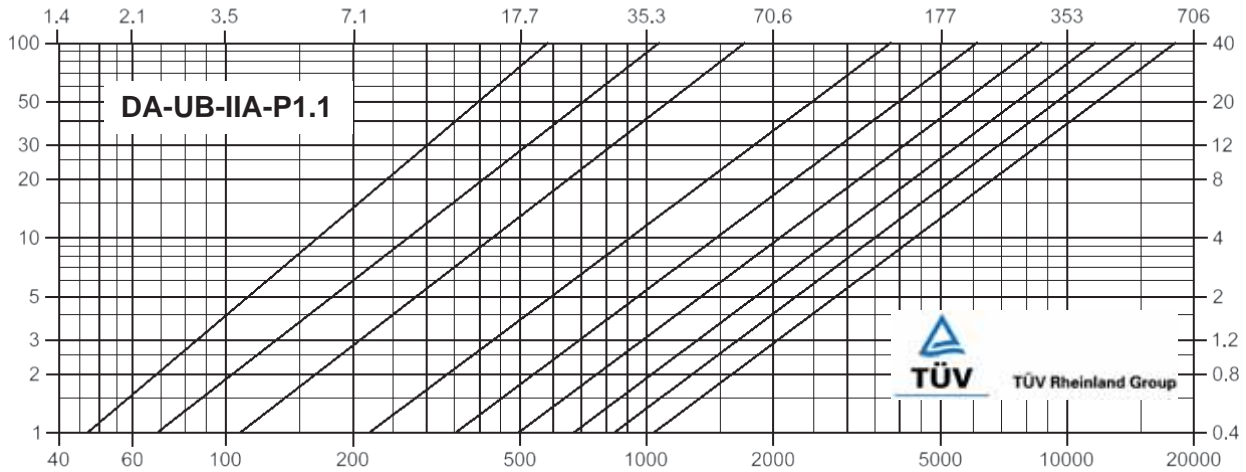

flow rate \dot{V} (m³/h)

1830-L

* P1.2

NG / DN
 150/50 (6" / 2") *
 150/80 (6" / 3") *
 200/100 (8" / 4") *
 300/150 (12" / 6")
 400/200 (16" / 8")
 500/250 (20" / 10")
 600/300 (24" / 12")
 700/350 (28" / 14")
 800/400 (32" / 16")

airflow in thousands of CFH

pressure drop Δp (mbar)

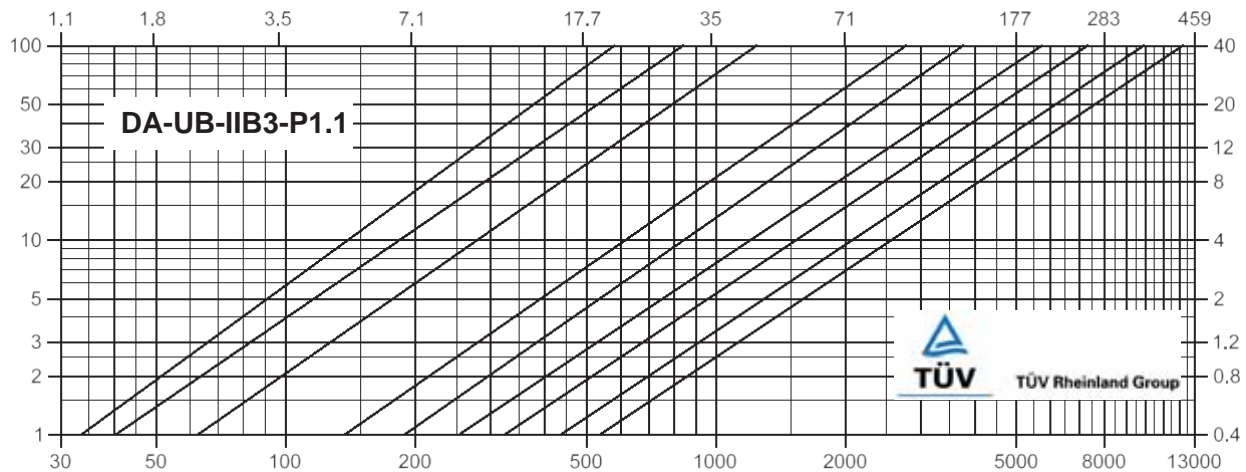

flow rate \dot{V} (m³/h)

1833-L

The flow capacity charts have been determined with a calibrated and TÜV certified flow capacity test rig. Volume flow \dot{V} in (m³/h) and CFH refer to the standard reference conditions of air ISO 6358 (20°C, 1bar). Conversion to other densities and temperatures refer to Vol. 1: "Technical Fundamentals".



for safety and environment



In-Line Detonation Flame Arrester

for unstable and stable detonations and deflagrations in a straight through design with shock absorber, bidirectional

PROTEGO® DA-CG

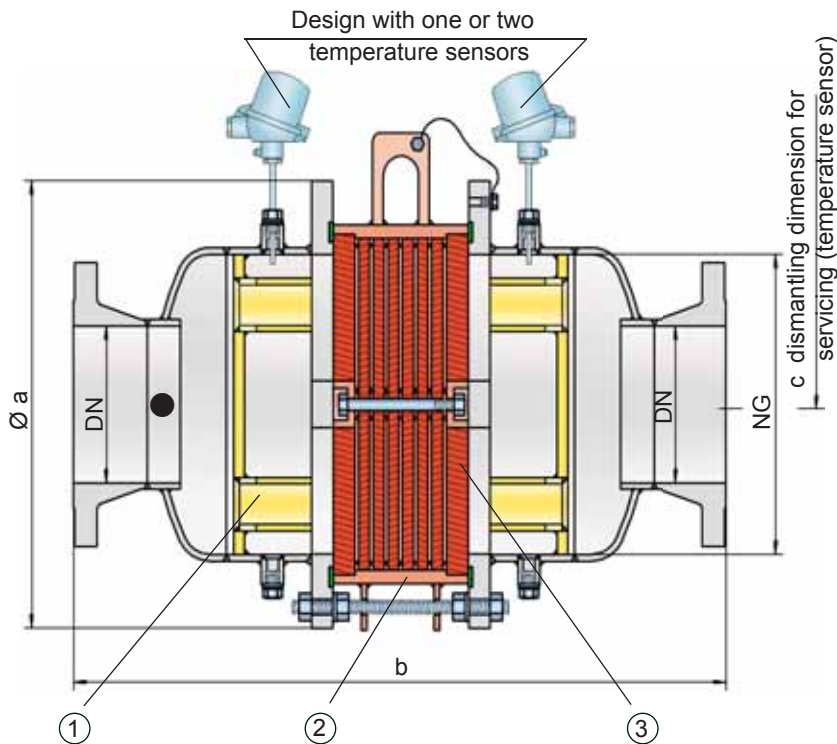

● Connection to the protected side (only for type DA-CG-T-....)

Function and Description

The PROTEGO® DA-CG series of detonation arresters was mainly developed for the North American market and optimized to meet the demands of the US Coast Guard. The devices are symmetrical and offer bidirectional flame arresting for deflagrations, stable and unstable detonations.

The speed of incoming detonations is greatly reduced by the effective shock absorber (1). This improves the flame extinction in the narrow gaps of the FLAMEFILTER® (3).

The flame arrester essentially consists of two housing parts with an integrated shock absorber and the PROTEGO® flame arrester unit (2) in the center. The PROTEGO® flame arrester unit is modular and consists of several FLAMEFILTER® discs and spacers firmly held in a FLAMEFILTER® cage. The number of FLAMEFILTER® discs and their gap size depends on the arrester's conditions of use.

By indicating the operating parameters such as the temperature, pressure and explosion group and the composition of the fluid, the optimum in-line detonation flame arrester can be selected. Type PROTEGO® DA-CG flame arresters are available for explosion groups IIA to IIB3 (NEC group D to C MESH ≥ 0.65 mm).

The standard design can be used up to an operating temperature of +60°C / 140°F and an absolute operating pressure acc. to table 3. Devices with special approvals can be obtained for higher pressures and higher temperatures upon request.

The flame arresters have been approved according to the American Standard 33 CFR part 154 and are accepted by the US Coast Guard.

Special Features and Advantages

- offers protection against deflagrations, stable and unstable detonations
- less number of FLAMEFILTER® discs from the use of the effective shock absorber
- modular flame arrester unit enables each individual FLAMEFILTER® discs to be replaced and cleaned
- different series allow increase of FLAMEFILTER® size for given flange connection resulting in lower pressure drop across the device
- service-friendly design
- also available for large nominal sizes
- expanded application range for higher operating temperatures and pressures
- bidirectional operation as well as any direction of flow and installation position
- Possible installation of temperature sensors
- minimum pressure loss and associated low operating and life-cycle cost
- cost efficient spare parts

Design Types and Specifications

There are three different designs available:

Basic in-line detonation flame arrester	DA-CG- <input type="checkbox"/>
In-line detonation flame arrester with integrated temperature sensor* as additional protection against short time burning from one side	DA-CG- <input type="checkbox"/> T
Detonation arrester with two integrated temperature sensors* as additional protection against short time burning from both sides	DA-CG- <input type="checkbox"/> TB

Additional special flame arresters upon request

*Resistance thermometer for device group II, category (1) 2 (GII cat. (1) 2)

Table 1: Dimensions												Dimensions in mm / inches	
To select nominal width/nominal size (NG/DN) - combination, please use the flow capacity charts on the following pages						Additional nominal width/nominal size (NG/DN) - combinations for improved flow capacity upon request							
standard													
NG	150 6"	150 6"	200 8"	300 12"	400 16"	500 20"	600 24"	700 28"	800 32"	1000 40"	1200 48"		
DN	≤ 50 2"	80 3"	≤ 100 4"	≤ 150 6"	≤ 200 8"	≤ 250 10"	≤ 300 12"	≤ 350 14"	≤ 400 16"	≤ 500 20"	≤ 600 24"		
a	285 / 11.22	285 / 11.22	340 / 13.39	460 / 11.18	580 / 22.83	715 / 28.15	840 / 33.07	1025 / 40.35	1025 / 40.35	1255 / 49.41	1485 / 58.46		
b	650 / 25.59	650 / 25.59	700 / 27.56	800 / 31.50	900 / 35.43	1100 / 43.31	1250 / 49.21	1500 / 59.06	1500 / 59.06	1700 / 66.93	2000 / 78.74		
c	300 / 11.81	300 / 11.81	330 / 12.99	380 / 14.96	490 / 19.29	540 / 21.26	590 / 23.23	690 / 27.17	690 / 27.17	790 / 31.10	880 / 34.65		

Table 2: Selection of the explosion group			
MESG	Expl. Gr. (IEC/CEN)	Gas Group (NEC)	
> 0,90 mm	IIA	D	Special approvals upon request
≥ 0,65 mm	IIB3	C	

Table 3: Selection of max. operating pressure												
Expl. Gr.	NG	150 6"	150 6"	200 8"	300 12"	400 16"	500 20"	600 24"	700 28"	800 32"	1000 40"	1200 48"
	DN	≤ 50 2"	80 3"	≤ 100 4"	≤ 150 6"	≤ 200 8"	≤ 250 10"	≤ 300 12"	≤ 350 14"	≤ 400 16"	≤ 500 20"	≤ 600 24"
	IIA	P _{max}	1.2 / 17.4	1.2 / 17.4	1.2 / 17.4	1.2 / 17.4	1.2 / 17.4	1.2 / 17.4	1.2 / 17.4	1.2 / 17.4	1.2 / 17.4	1.2 / 17.4
	IIB3	P _{max}	1.6 / 23.2	1.6 / 23.2	1.6 / 23.2	1.6 / 23.2	1.6 / 23.2	1.6 / 23.2	1.6 / 23.2	1.6 / 23.26	1.6 / 23.2	1.6 / 23.2

P_{max} = maximum allowable operating pressure in bar / psi (absolute), higher operating pressure upon request

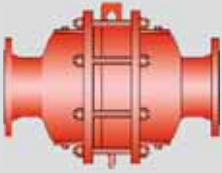

In-Line Detonation Flame Arrester

for unstable and stable detonations and deflagrations in a straight through design with shock absorber, bidirectional

PROTEGO® DA-CG

Table 4: Specification of max. operating temperature

≤ 60°C / 140°F	higher operating temperatures upon request
T60	T _{maximum allowable operating temperature in °C}

Table 5: Material selection for housing

Design	A	B	Special materials upon request
Housing	Steel	Stainless Steel	
Gasket	PTFE	PTFE	
Flame arrester unit	A	B	

Table 6: Material combinations of the flame arrester unit

Design	A	B	*the FLAMEFILTER® are also available in the materials Tantalum, Inconel, Copper, etc. when the listed housing and cage materials are used.
FLAMEFILTER® cage	Steel	Stainless Steel	
FLAMEFILTER® *	Stainless Steel	Stainless Steel	
Spacer	Stainless Steel	Stainless Steel	

Special materials upon request

Table 7: Flange connection type

EN 1092-1, Form B1 or DIN 2501, Form C, PN 16; from DN 200 PN 10	EN or DIN	other types upon request
ANSI 150 lbs RFSF	ANSI	

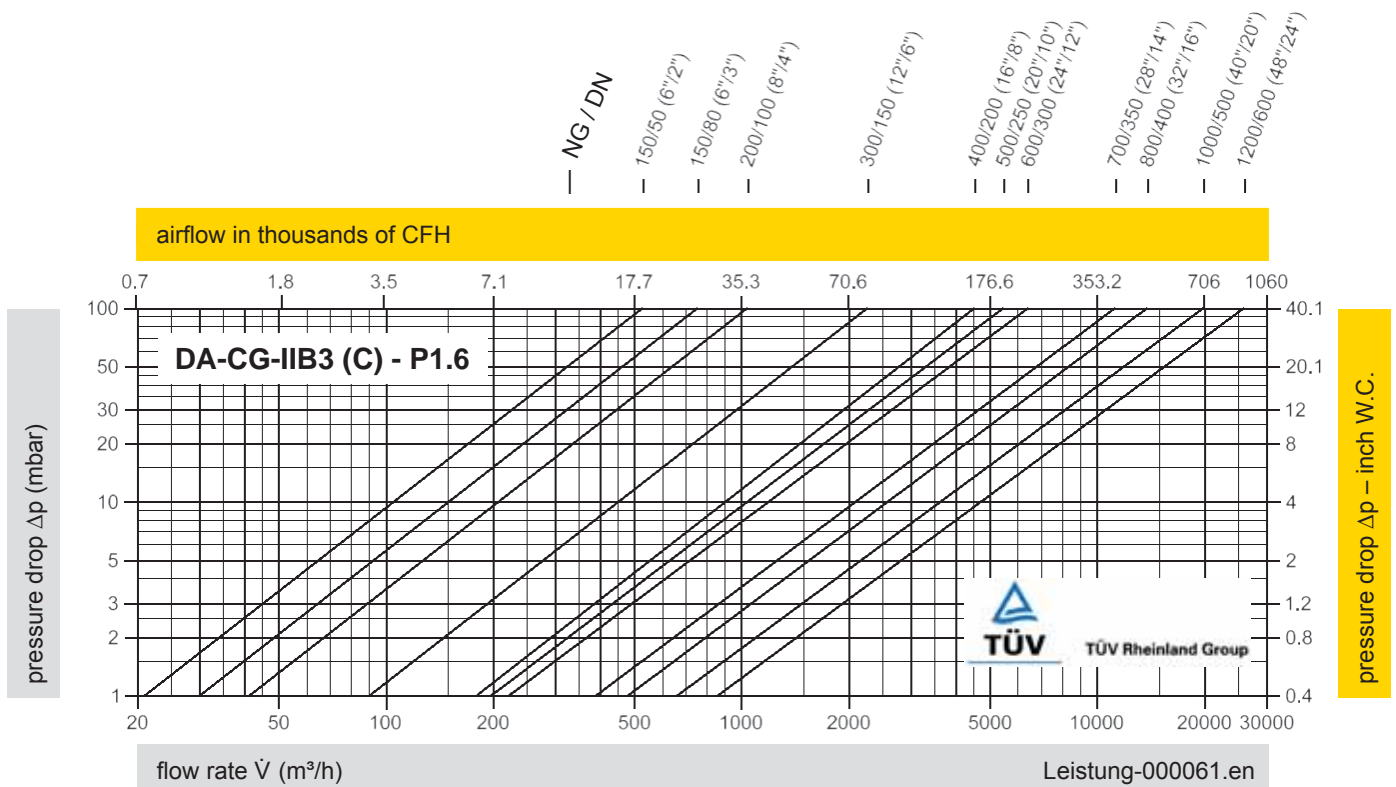
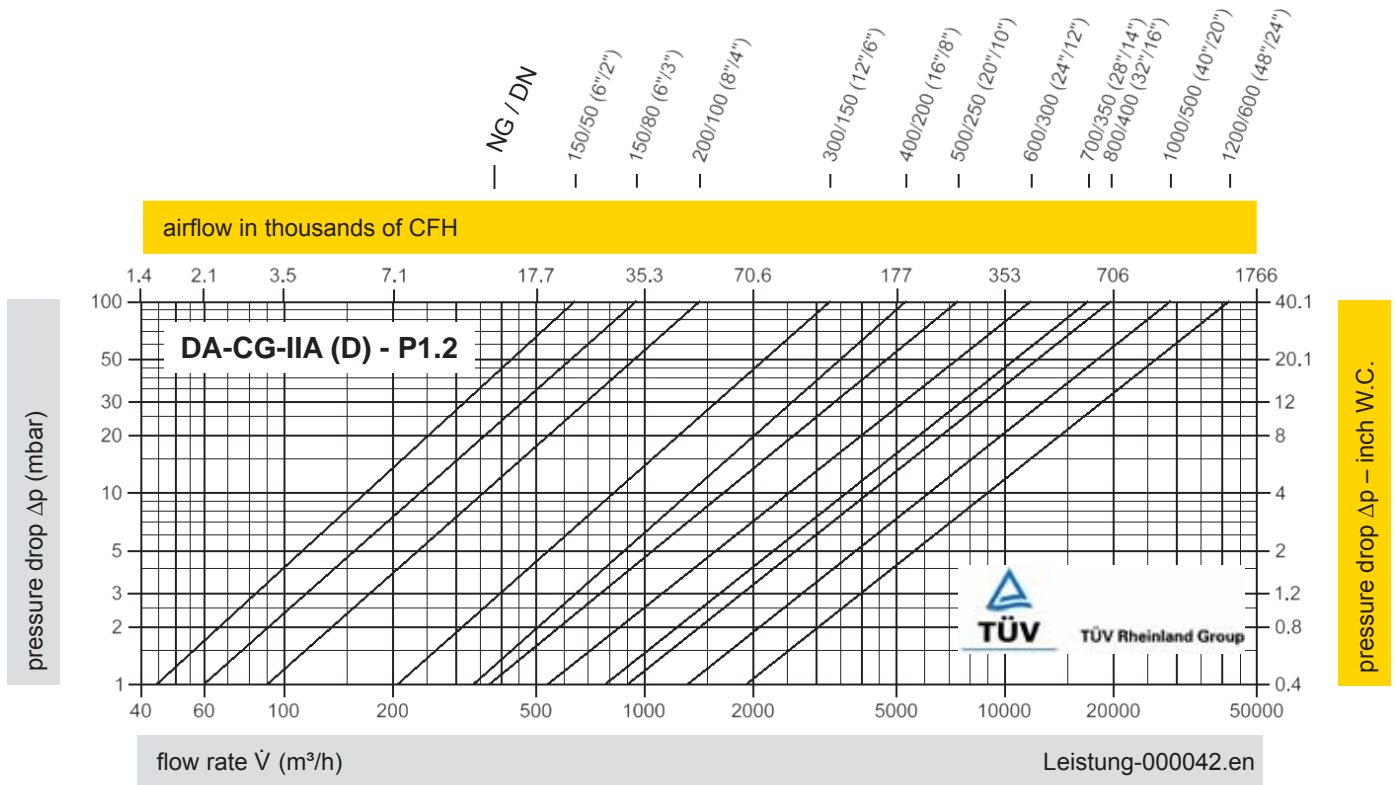

The flow capacity charts have been determined with a calibrated and TÜV certified flow capacity test rig. Volume flow \dot{V} in (m³/h) and CFH refer to the standard reference conditions of air ISO 6358 (20°C, 1bar). Conversion to other densities and temperatures refer to Vol. 1: "Technical Fundamentals".



for safety and environment



In-Line Detonation Flame Arrester

for unstable and stable detonations and deflagrations in right angle design with a shock absorber, unidirectional

PROTEGO® DR/EU

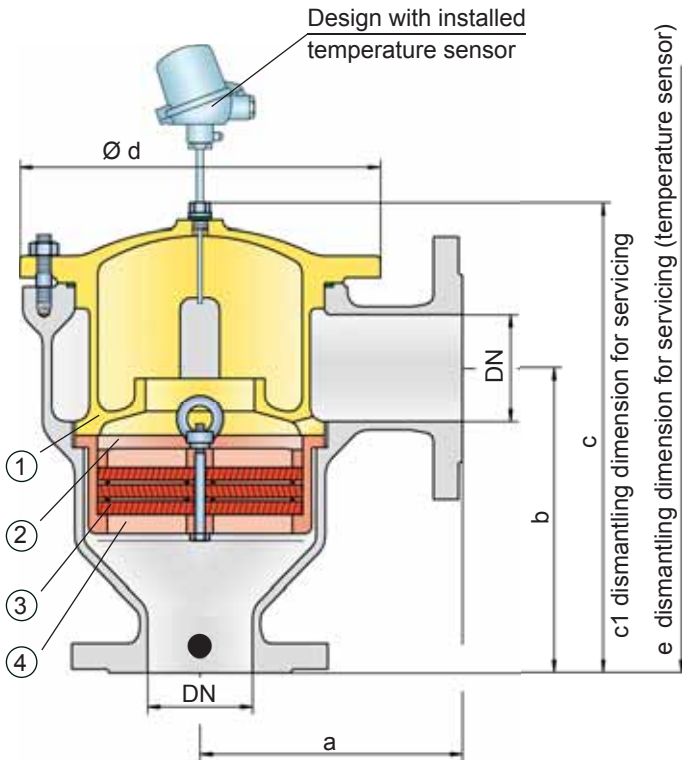

● Connection to the protected side

Function and Description

The PROTEGO® DR/EU series of in-line detonation flame arresters represents a further development of PROTEGO® flame arresters DR/ES used successfully for decades in industry. The device protects against deflagrations, stable and unstable detonations. The classic right angle design offers considerable cost and maintenance advantages in comparison to a straight through design.

Once a detonation enters the flame arrester, energy is absorbed from the detonation shock wave by the integrated shock absorber (1) before the flame is extinguished in the narrow gaps of the FLAMEFILTER® (3).

The PROTEGO® flame arrester unit (2) consists of several FLAMEFILTER® discs and spacers firmly held in the FLAMEFILTER® cage (4). The gap size and number of FLAMEFILTER® discs are determined by the operating data parameters of the mixture flowing in the line (explosion group, pressure, temperature). This device is available explosion groups from IIA to IIB3 (NEC group D to C MESH ≥ 0.65 mm).

The standard design can be used up to an operating temperature of +60°C / 140°F and an absolute operating pressure acc. to table 3. Numerous special approvals can be obtained for higher temperatures and pressures upon request.

Type-approved according to ATEX Directive 94/9/EC and EN ISO 16852 as well as other international standards.

Special Features and Advantages

- minimum number of FLAMEFILTER® discs due to the effective shock absorber
- quick removal and installation of the complete PROTEGO® flame arrester unit and of the FLAMEFILTER® discs in the cage
- modular flame arrester unit enables each individual FLAMEFILTER® discs to be replaced and cleaned
- provides protection from deflagration as well as from stable and unstable detonation
- the right angle design saves pipe elbows
- extended application range for higher operating temperatures and pressures
- minimum pressure loss and hence low operating and lifecycle costs
- cost efficient spare parts

Design Types and Specifications

There are four different designs available:

Basic in-line detonation flame arrester	DR/EU-	<input type="checkbox"/>	<input type="checkbox"/>
In-line detonation flame arrester with integrated temperature sensor* as additional protection against short time burning	DR/EU-	<input checked="" type="checkbox"/>	<input type="checkbox"/>
In-line detonation flame arrester with heating jacket	DR/EU-	<input checked="" type="checkbox"/>	<input type="checkbox"/>
in-line detonation flame arrester with integrated temperature sensor* and heating jacket	DR/EU-	<input checked="" type="checkbox"/>	<input checked="" type="checkbox"/>

*Resistance thermometer for device group II, category (1) 2 (GII cat. (1) 2)

Table 1: Dimensions

Dimensions in mm / inches

To select the nominal size (DN), please use the flow capacity charts on the following pages

DN	25 / 1"	32 / 1 ¼"	40 / 1 ½"	50 / 2"	65 / 2 ½"	80 / 3"	100 / 4"	125 / 5"	150 / 6"
a	125/4.92	125/4.92	153/6.02	155/6.10	198/7.80	200/7.87	250/9.84	332/13.07	335/13.19
b	140/5.51	140/5.51	183/7.20	185/7.28	223/8.78	225/8.86	290/11.42	357/14.06	360/14.17
c	210/8.27	210/8.27	290/11.42	290/11.42	365/14.37	365/14.37	440/17.32	535/21.06	535/21.06
c1	285/11.22	285/11.22	395/15.55	395/15.55	500/19.69	500/19.69	595/23.43	750/29.53	750/29.53
d	150/5.91	150/5.91	210/8.27	210/8.27	275/10.83	275/10.83	325/12.80	460/18.11	460/18.11
e	495/19.49	495/19.49	600/23.62	600/23.62	705/27.76	705/27.76	795/31.30	950/37.40	950/37.40

Table 2: Selection of the explosion group

MESG	Expl. Gr. (IEC/CEN)	Gas Group (NEC)	Special approvals upon request
> 0,90 mm	IIA	D	
≥ 0,75 mm	IIB2	C	
≥ 0,65 mm	IIB3	C	

Table 3: Selection of max. operating pressure

DN		25 / 1"	32 / 1 ¼"	40 / 1 ½"	50 / 2"	65 / 2 ½"	80 / 3"	100 / 4"	125 / 5"	150 / 6"
Expl. Gr.	IIA P _{max}	1.6 / 23.2	1.6 / 23.2	1.6 / 23.2	1.6 / 23.2	1.6 / 23.2	1.6 / 23.2	1.5 / 21.7	1.2 / 17.4	1.2 / 17.4
	IIB2 P _{max}								1.4 / 20.3	1.4 / 20.3
	IIB3 P _{max}	1.6 / 23.2	1.6 / 23.2	1.6 / 23.2	1.6 / 23.2	1.6 / 23.2	1.6 / 23.2	1.6 / 23.2	1.4 / 20.3	1.2 / 17.4*

P_{max} = maximum allowable operating pressure in bar / psi (absolute), higher operating pressure upon request

* special flame arrester unit

Table 4: Specification of max. operating temperature

≤ 60°C / 140°F	higher operating temperatures upon request
T60	T _{maximum allowable operating temperature in °C}

Table 5: Material selection for housing

Design	B	C	D	* for devices exposed to elevated temperatures above 150°C / 302°F (T150), gaskets made of PTFE. The housing and cover with the shock absorber can also be delivered in steel with an ECTFE coating.
Housing	Carbon Steel	Stainless Steel	Hastelloy	
Heating jacket (DR/EU-H-(T)-...)	Steel	Stainless Steel	Stainless Steel	
Cover with shock absorber	Steel	Stainless Steel	Hastelloy	
O-Ring	FPM *	PTFE	PTFE	
Flame arrester unit	A	C, D	E	

Special materials upon request

Table 6: Material combinations of the flame arrester unit

Design	A	C	D	E	* the FLAMEFILTER® are also available in the materials Tantalum, Inconel, Copper, etc. when the listed housing and cage materials are used.
FLAMEFILTER® cage	Steel	Stainless Steel	Stainless Steel	Hastelloy	
FLAMEFILTER® *	Stainless Steel	Stainless Steel	Hastelloy	Hastelloy	
Spacer	Stainless Steel	Stainless Steel	Hastelloy	Hastelloy	

Special materials upon request

Table 7: Flange connection type

EN 1092-1, Form B1 or DIN 2501, Form C, PN 16; from DN 200 PN 10	EN or DIN	other types upon request
ANSI 150 lbs RFSF	ANSI	



for safety and environment



In-Line Detonation Flame Arrester

Flow Capacity Charts

PROTEGO® DR/EU

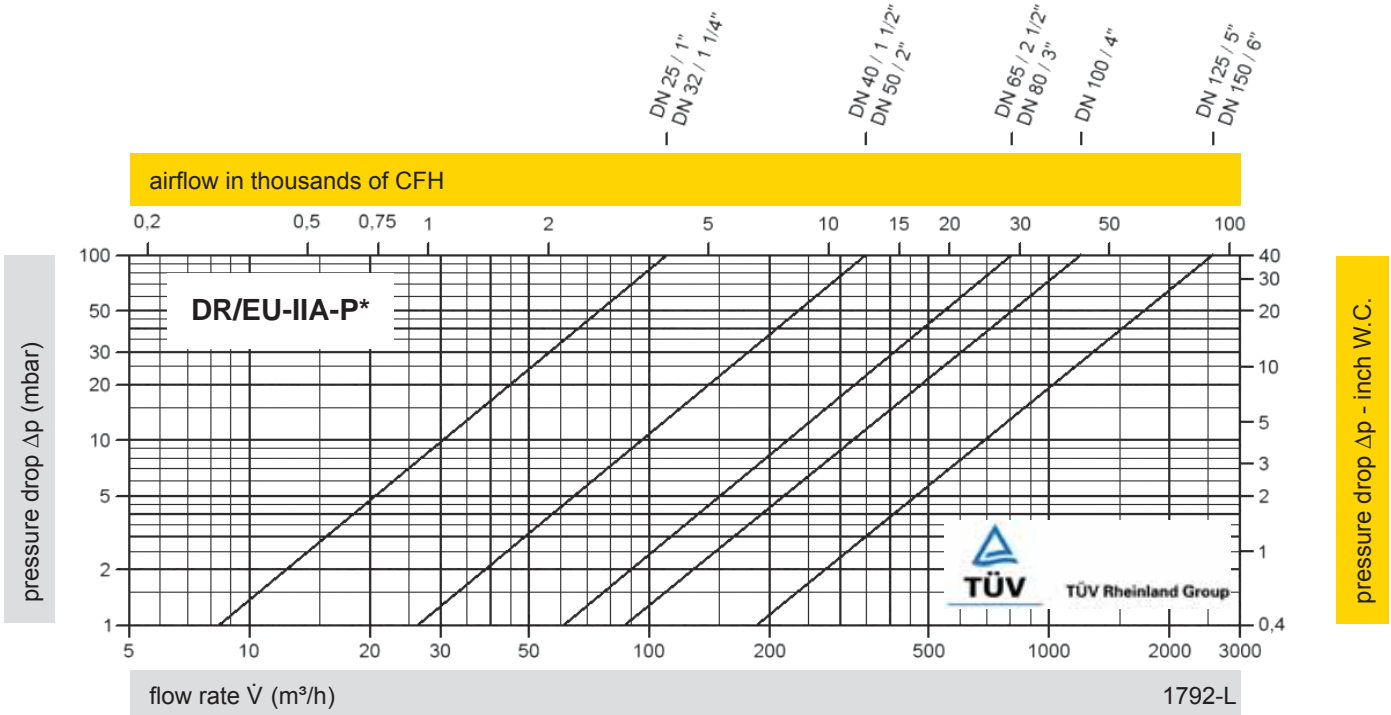

P* see table 3

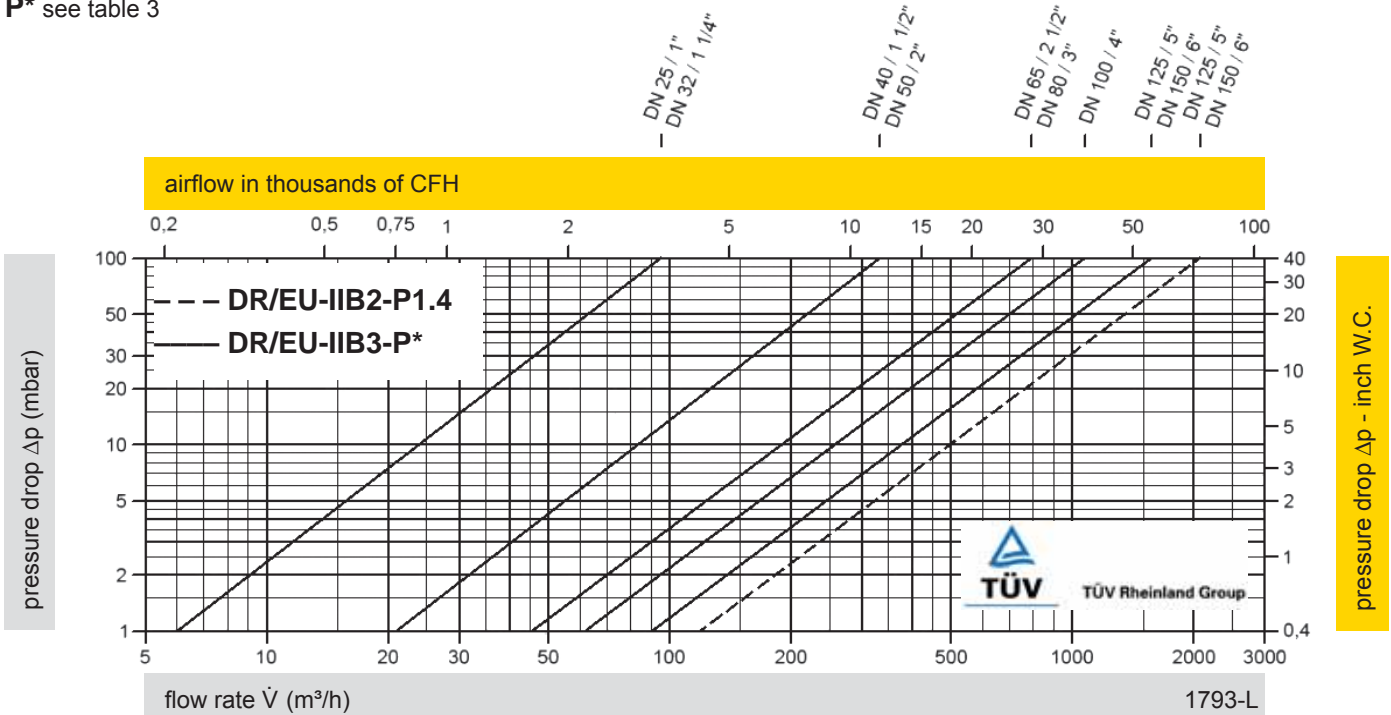

The flow capacity charts have been determined with a calibrated and TÜV certified flow capacity test rig. Volume flow \dot{V} in (m³/h) and CFH refer to the standard reference conditions of air ISO 6358 (20°C, 1bar). Conversion to other densities and temperatures refer to Vol. 1: "Technical Fundamentals".

www.protego.de



for safety and environment