



Installation & Operation Manual

Table Of Contents

CHAPTER 1 MBIII FUNCTIONAL DESCRIPTION	
1.1 MBIII Mounting	1-2
1.2 Control Solenoid	1-2
1.3 Meter Sensor	1-3
1.4 3-Way Diverter Valve	1-3
CHAPTER 2 MBIII WIRING	
2.1 Control Solenoid	2-1
2.2 Meter Sensor - General	2-1
2.3 Meter Sensor – Pulse Signal Output	2-1
2.4 Customer Equipment for Meter Sensor Input	2-2
CHAPTER 3 MBIII FLUID CONNECTIONS	
3.1 Fluid Inlet Piping	3-1
3.2 Fluid Outlet Piping	3-1
3.3 Thermal Expansion Relief	3-2
3.4 Equipment connections	3-2
CHAPTER 4 SPECIFICATIONS	
3.1 Control Solenoid	4-1
3.2 Meter & Sensor	4-1
CHAPTER 5 PARTS ASSEMBLY DRAWING	
5.1 Parts List (ATEX)	5-2
5.2 General Arrangement Drawing	5-3
CHAPTER 6 ELECTRICAL CONNECTION DRAWINGS	
6.1 MBIII Sensor Lead Identification	6-1
6.2 Sourced Inputs	6-2
6.3 Un-sourced Inputs	6-2
CHAPTER 7 MBIII STANDARD FEATURES	
7.1 Optional Features	7-1

CHAPTER 1 MONO-BLOCK™ III FUNCTIONAL DESCRIPTION

The Mono-Block™ III manifold is a low cost solution to chemical additive injection in the petroleum terminal environment. This manifold design meets the entire standard requirements for metering and control of a cyclical injection chemical stream. The Mono-Block™ III provides an electrically operated solenoid valve and a precision fluid meter in a common manifold. In addition, the manifold includes an inlet strainer, a calibration security diverter valve with integral flow control and an outlet check valve. Combining this functionality into a single manifold block reduces the size of the instrumentation. This is critical in the limited spaces available on truck loading racks today. Additionally, combining the solenoid, meter, and test port into a single manifold eliminates most potential leak points common to component built injectors assembled in the field.

This manifold block provides the physical instrument needed to allow a Terminal Automation System, Preset, or PLC System to directly control chemical additive injection. This manifold does not include the electronics control necessary to pace the chemical to a flowing fuel stream, nor does it contain the logic necessary to accumulate additive volume passing through it.

AC line voltage is typically used to energize the solenoid valve and allow flow. The controlling device (e.g. Mini-Pak Controller) then accumulates flow volume in the form of pulses transmitted from the meter sensor. When sufficient volume of additive chemical has moved through the manifold, the controlling device then turns off the solenoid valve in order to stop flow. It is the responsibility of the controlling device, Terminal Automation System, Preset, or PLC System, to perform the algorithms necessary to ratio the chemical properly into the fuel stream. Functionality for recipe, injection interval, tolerance, alarm annunciation, shutdown, etc. are all the responsibility of the controlling system. If the controlling system is not capable of this level of function, manifold blocks alone are not the solution. The user should consult our factory for information on complete injection panels that include microprocessor based controllers having the capability of complete injection control.

1.1 MONO-BLOCK™ III MOUNTING

The Mono-Block™ III manifold may be mounted in any orientation provided the gear axles remain horizontal. The inlet and outlet ports can be up, down, left, or right. The arrowed line in the sketch below depicts the horizontal axis of the gear axles in the block. When choosing a mounting position, make certain that the arrowed line remains orientated horizontally.

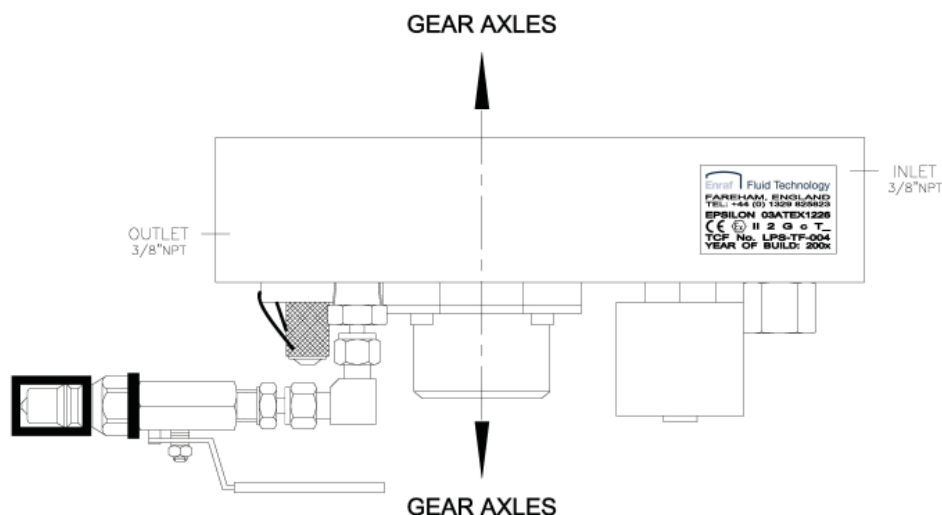

1.2 MONO-BLOCK™ III SOLENOID INPUT

The Mono-Block™ III manifold has a single control input. That input is the electrical connections to the actuator coil of the solenoid valve. The coil is typically operated from AC line voltage (110-240V) and frequency (50/60Hz) common to the area of the world into which the block is sold. Optionally, DC coils in 12 volt and 24 volt models are available. Coil voltage is model dependent and should be specified when placing the equipment order.

The solenoid valve is normally closed. This means that when the coil is de-energized (no voltage applied) the valve is closed. Applying the rated voltage to the coil opens the fluid flow path through the Mono-Block™ III.



1.3 MONO-BLOCK™ III SENSOR OUTPUT

The Mono-Block™ III meters the fluid flowing through it. Two high precision oval gears are mounted in a measuring chamber machined into the block. As fluid passes through the measuring chamber, the fluid force rotates the gears. Imbedded into the gears are four high field strength rare earth magnets. As the gears rotate, these magnets pass beneath a Hall-Effect pickup mounted in the sensor housing. The magnetic field from the gear magnets causes the Hall-Effect pickup to change state (off-on-off) as each magnet passes. Approximately 4,800 pulses are generated for each gallon of fluid passing through the meter (1270 pulses/litre). (Different nominal resolutions are available as options.)

The customer's equipment is responsible for providing a means of calibration of the meter. That is, a method of determining the exact number of pulses per gallon, liter, etc. of fluid. This calibration factor is normally referred to as the "K-Factor" for the meter. The k-factor is then used by the customer's equipment for conversion of pulses received to volume dispensed.

1.4 MONO-BLOCK™ III 3-WAY DIVERTER VALVE

Mounted on the discharge side of the MonoBlock III is the 3-Way Diverter Valve. The valve consists of a 'hand tight' knurled barrel, scored. With a position indication line. The valve can be positioned to 'injection' (INJ) or calibration (CAL) positions. 'Injection' directs flow to the discharge port of the MonoBlock and on to the point of injection, whilst positively isolating the calibration port. Conversely 'Calibration' directs flow to the calibration port whilst positively isolating the discharge port. His operation ensures that additive flow can only ever be in one direction.

Located under the Allan headed bolt, is a flat blade screwdriver adjustable, flow control adjuster. This allows for the variable control of flow-rate through the valve. The default position being fully open, the adjustment is most commonly made to reduce the flow-rate of the additive at very low injection rates, there-by elongating the injection period and enhancing flow control. The valve is also pre-drilled to allow for the fixing of tamper-proof security wiring.

Intentionally left blank.

CHAPTER 2 MONO-BLOCK™ III WIRING

2.1 Control Solenoid

The solenoid wiring should be a minimum of #16 AWG/1.5mm² and a maximum of #14 AWG/2.5mm², type THHN or THWN wire. Good practice dictates AC and DC wiring should be run in separate conduits or multi-core cables for extended distances. Follow local, state, and federal codes and practices applicable to your area.



WARNING! *The solenoid coil presents an inductive load to the switching device controlling it. High counter EMF voltages may be produced when removing the voltage source from such loads. Steps should be taken to ensure these high surge voltages are properly dissipated, or damage to the controlling device may occur. Consult with the manufacturer of the controlling equipment for guidance regarding the control of inductive loads. Triac switching is recommended.*



2.2 Meter Sensor (general)

The sensor wiring can be three conductor, #18-22 AWG/0.5-1mm² shielded instrument cable, with a foil or braided wire shield. Use Belden® number 9363 or similar. Drain or screen wires should be terminated on a DC COMMON or on a specifically assigned shield termination at the controller end only. Do not terminate shields to AC earth ground. Tape off and isolate the shield at the sensor end. Refer to wiring diagrams in this document for specific connection details.

2.3 Meter Sensor - Pulse Signal Output

The Mono-Block™ III meter sensor output is an un-sourced, open collector, NPN transistor output. The blue sensor wire is connected to the transistor collector. The emitter of the transistor is connected to the black

wire, or DC COMMON connection. The term “un-sourced” means that no voltage is applied to the output from within the sensor. It must be pulled to a ‘high’ or ‘on’ or ‘true’ state by voltage supplied from an external source. The sensor electronics then drives the collector ‘low’ or ‘off’ or ‘false’ with each pulse transmitted. The output is NOT driven high internally within the sensor. This industry common scheme allows the sensor to drive external equipment supplied by its own internal transmitter power. There must be a common connection between the DC negative of the sensor supply and the DC COMMON of the signal accumulating device. Refer to the wiring diagrams at the end of this manual for specific connection details.

2.4 Customer Equipment for Meter Sensor Input

The controlling equipment used for capturing pulses from the Mono-Block™ III may be of two general categories; Un-sourced Inputs, having no voltage present normally on the input connection; Sourced Inputs, having a DC pull-up voltage supplied to the input connection. Two different wiring methods are used for the two types of pulse inputs. Wiring diagrams are provided at the end of this document for each type of input. Refer to the documentation for the controlling equipment for a description of the inputs to determine the type. If the documentation still does not resolve the issue, the following test can be performed.

A digital volt-ohm meter is used to test the equipment input for the presence of voltage. Use the setup in the sketch below. Place the meter in the DC Voltage mode. Disconnect any wires on the DC Pulse Input. Power the controller. Measure the voltage from the DC COMMON terminal (black voltmeter lead) to the DC Pulse Input (red voltmeter lead). If the voltage reading is greater than +5.0 volts, the input is considered a sourced input. If the voltage reading is less than +5.0 volts, the input is considered an un-sourced input. Refer to the corresponding wiring diagram for connections.

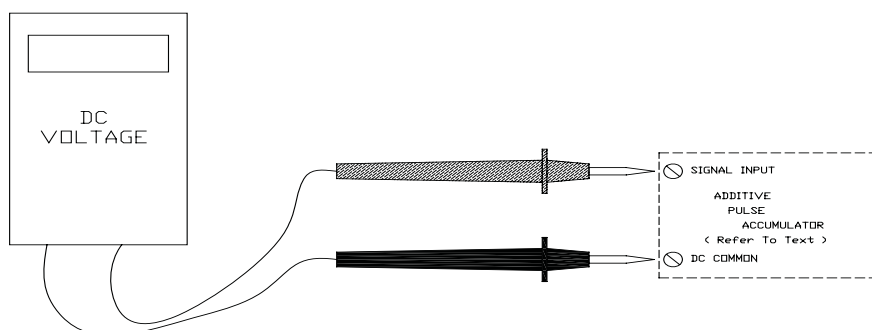

Test setup for determining customer equipment input type.
 > +5.0 Volts = Sourced Input
 < +5.0 Volts = Un-sourced Input

CHAPTER 3 MONO-BLOCK™ III FLUID CONNECTIONS

The fluid inlet and outlet of the Mono-Block™ III manifold is marked with engraved text on the block. The inlet pressure should always be higher than the outlet pressure to ensure proper operation.

3.1 Fluid Inlet Piping

Attention should be given to flow dynamics when sizing the tubing, isolation valve, and strainer components feeding the injector inlet. The minimum tubing size for flows approaching the 3 gall/min (12 litre/min) maximum flow rate through the Mono-Block™ III is ½". Significantly lower flow rates may allow smaller tubing dimensions. The isolation valve, feed pipe and strainer size must be increased to handle the flow required for the number of blocks being fed.

3.2 Fluid Outlet Piping

Stainless steel tubing is also used for piping the outlet of the Mono-Block™ III manifold to the point of injection.



WARNING! *A check valve and an isolation valve MUST be installed between the manifold and the point of injection! Failure to install an isolation valve will require complete fuel delivery system shutdown in the event of a need for service on the injector manifold. Failure to install a check valve in the line may result in fuel backing up into the additive chemical delivery system and may cause contamination or spill.*

Good design practice dictates that an isolation valve, usually a quarter turn ball valve, be installed at the point of chemical injection into the fuel piping. This valve should meet the needs of local policies and practices regarding piping system valves.

An injection point check valve is required. This check valve should be a positive shut-off, spring closed check such as a plug or ball type. A small opening or 'cracking' pressure is acceptable, generally limited to a maximum of 15 PSI/1Bar. Cracking pressures of 1 PSI to 10 PSI/0.06 to 0.6 Bar are common in the industry. Ensure the flow characteristic (Cv) of the check valve is adequate to handle the maximum flow rate expected through the injector manifold. Although the location is not critical, it is common practice to place the check valve near the isolation valve at the point of injection.

Remember, pressure differentials across the isolation valve, check valve, tubing, manifold, strainer, etc. all accumulate and ultimately dictate the required supply pump pressure. Minimizing the individual pressure drops allow the lowering of the supply pump pressure and effectively reduces the load and wear on the system.



WARNING! Care should be exercised when connecting multiple injector manifold blocks to one common point of injection. Each manifold line **MUST** have its own check valve to prevent cross contamination. The length of common piping should be minimized to ensure all additive chemical being injected reaches the fuel line. Not all chemicals are compatible. If multiple additives are used simultaneously, be certain to size common piping for the combined flow.

3.3 Thermal Expansion Relief

Thermal relief bypass kits may be required with the Mono-Block™ III manifold when installed with a point-of-injection actuated valve. This includes a solenoid valve or electric or pneumatic actuated ball valve.

The Mono-Block™ III manifold will stop flow in the reverse direction when the solenoid is de-energized. The check valve in the block prevents reverse flow. When the additive chemical injection system is idle, any fluid expansion that occurs between the block and the point of injection **MUST** be relieved, usually back to additive storage. When designing the pumping system, provision should be made to allow this thermal expansion volume to return to the additive chemical storage tank.

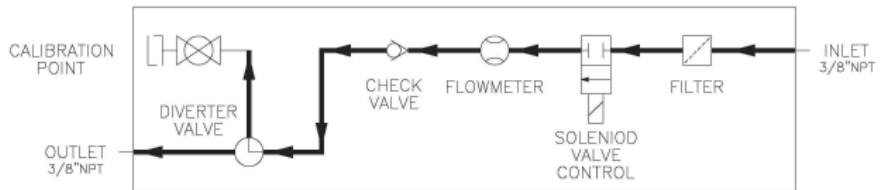

Mono-Block™ III Process and Instrumentation Diagram (P&ID)

3.4 EQUIPMENT CONNECTIONS

Solenoid:

Two Red Wires: Actuator Coil
 Green Wire w/ Yellow Stripe: Earth Ground

Meter Pickup Sensor:

(3-wire, Hall-Effect pickup)
 Red Wire: Sensor Power
 Black Wire: Power & Signal Common
 Blue Wire: Pulse Signal

Fluid:

Inlet: 3/8" Female NPT
 Outlet: 3/8" Female NPT
 Test Port: 3/8" Female NPT

CHAPTER 4 SPECIFICATIONS

4.1 CONTROL SOLENOID

General Data:

Fluid Port Sizes:	5/16" – 8mm
Material (Body):	304 Stainless Steel
Max Working Pressure:	235 PSI, 16Bar
Max Differential Pressure:	150 PSI, 10Bar
Certifications:	UL Listed 106A, CSA®, ATEX.

Coil Data:

Power Req.:	17.1 Watts @ 120 VAC, 8.6 Watts @ 240 VAC
Certifications:	NEMA Type 3, 35, 4, 4X, 6, 6P, 7, & 9 ATEX

4.2 METER & PICKUP SENSOR

Manifold Block Physical:

Fluid Port Sizes:	3/8" FNPT
Material (Body):	303 Stainless Steel
Material (Elastomers):	Teflon
Max Working Pressure:	400 PSI, 27Bar

Fluid Metering Gears:

Nominal Pulse Resolution:	2400 pulses/gallon (635 pulses/litre) in water (Full Height Gear)
Nominal Pulse Resolution:	4800 pulses/gallon (1270 pulses/litre) in water (Half Height Gear)
Material (Gears):	Ryton™ (Phillips Petroleum Co.)

Sensor Physical:

Sensor Thread:	1/2" x 13 S.A.E. threads, female
Material:	Aluminum

Sensor Electrical:

Type:	Solid-state, bi-polar magnetic gated, open collector output
Sensor Power:	5vdc to 25vdc, 20 mA maximum
Open Collector Output:	5vdc to 25dc, 100 mA maximum (un-sourced)
3-wire Connection -	
Red Wire Function:	Sensor power
Black Wire Function:	Sensor power common & emitter (signal common)
Blue Wire Function:	Sensor signal, open collector output (un-sourced)

Environmental:

Ambient Operating Range:	-40°F to 150°F, -40°C to 66°C
--------------------------	-------------------------------

Specifications

Intentionally left blank.

CHAPTER 5 MONO BLOCK III PARTS ASSEMBLY

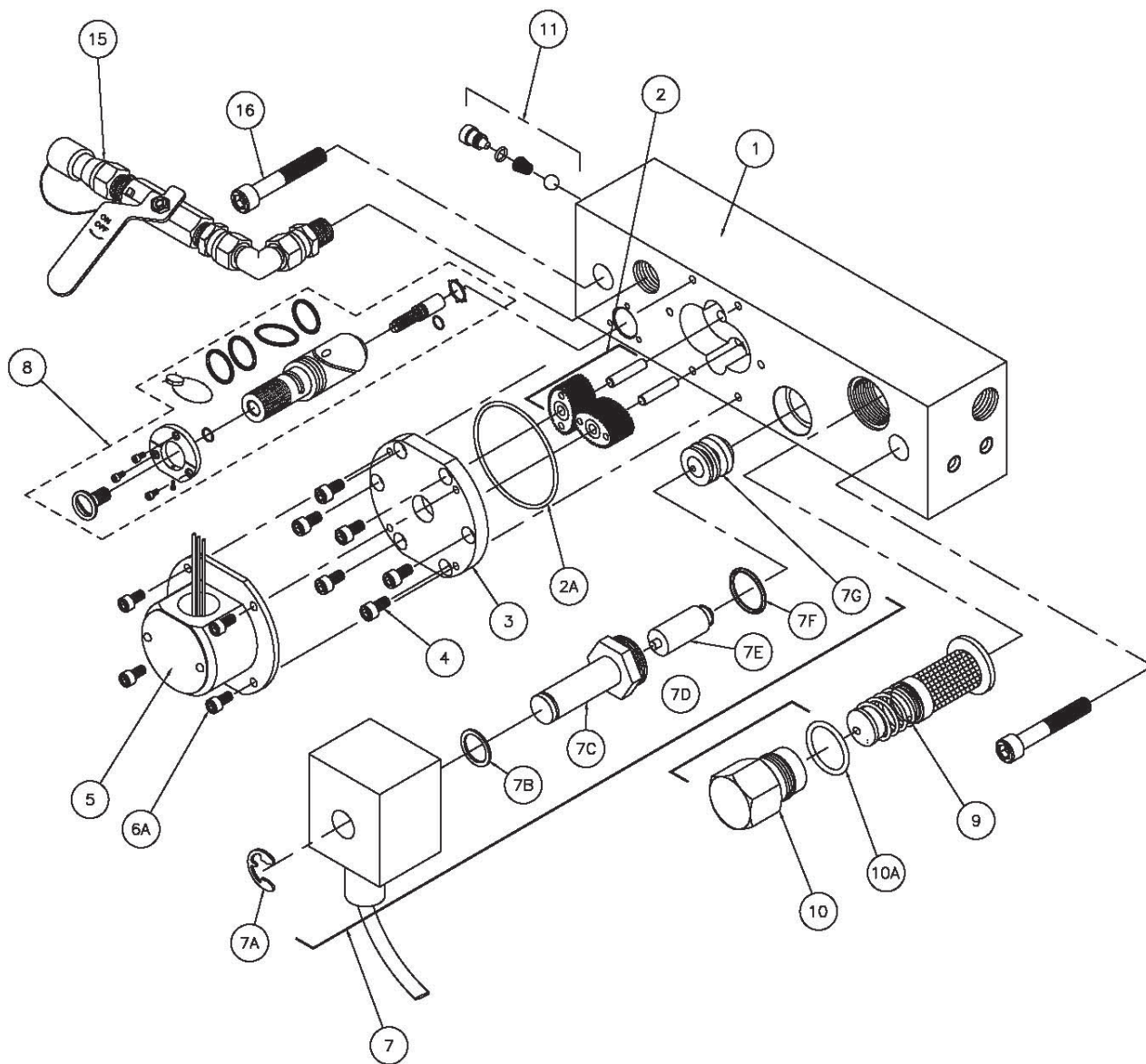

Refer to the next page for the parts identification table.

5.1 MONO-BLOCK III (ATEX VERSION)

NO.	QTY.	PART DESCRIPTION	PART NO.
1	1	MONOBLOCK III MANIFOLD S/STEEL.	30-10-020
	OPT1	MONOBLOCK III MANIFOLD S/STEEL(Low Flow)	30-10-020A
2	1	GEAR SET 'STD'HEIGHT+POST+'O'RING.	30-40-00
	OPT1	GEAR SET '1/2'HEIGHT+POST+'O'RING(Low Flow)	30-40-01
2A	1	FLOWMETER CAP 'O'RING	3-033
3	1	FLOWMETER CAP (MOMOBLOCK)	30-10-011
4	6	M5 SOCKET CAP SCREW	M5-12-01
5	1	SENSOR ASSEMBLY(MONO-BLOCK)	10-31558
6	4	M4 SPRING WASHER	30-80-09
6A	4	M4 SOCKET CAP SCREW	30-80-08
7	OPT1	ASCO SOLENOID 230V 50Hz T3 (STD)	30-00-65
	1	ALCON SOLENOID 230V 50Hz T5 (STD)	30-60-047
8	1	DIVERTER VALVE ASSEMBLY	30-10-021
9	1	FILTER ELEMENT	30-30-010
9A	1	FILTER ELEMENT	30-30-010B
10	1	FILTER CAP	30-30-008
10A	1	FILTER CAP SEAL	2-017
11	1	CHECK VALVE ASSEMBLY	30-00-010BA
15	1	CALIBRATION ASSEMBLY(QRC)	30-01-37-20
16	2	MOUNTING SCREWW M8 X 70mm(15mm)	M8-70-01
16A	2	MOUNTING SCREWW M8 X 80mm(30mm)	M8-80-01
16B	2	MOUNTING SCREWW M8 X 1200mm(60mm)	M8-120-01

ATEX VERSION ONLY - item numbers refer to the drawing on the previous page.

5.2 MONO-BLOCK™ III GENERAL ARRANGEMENT

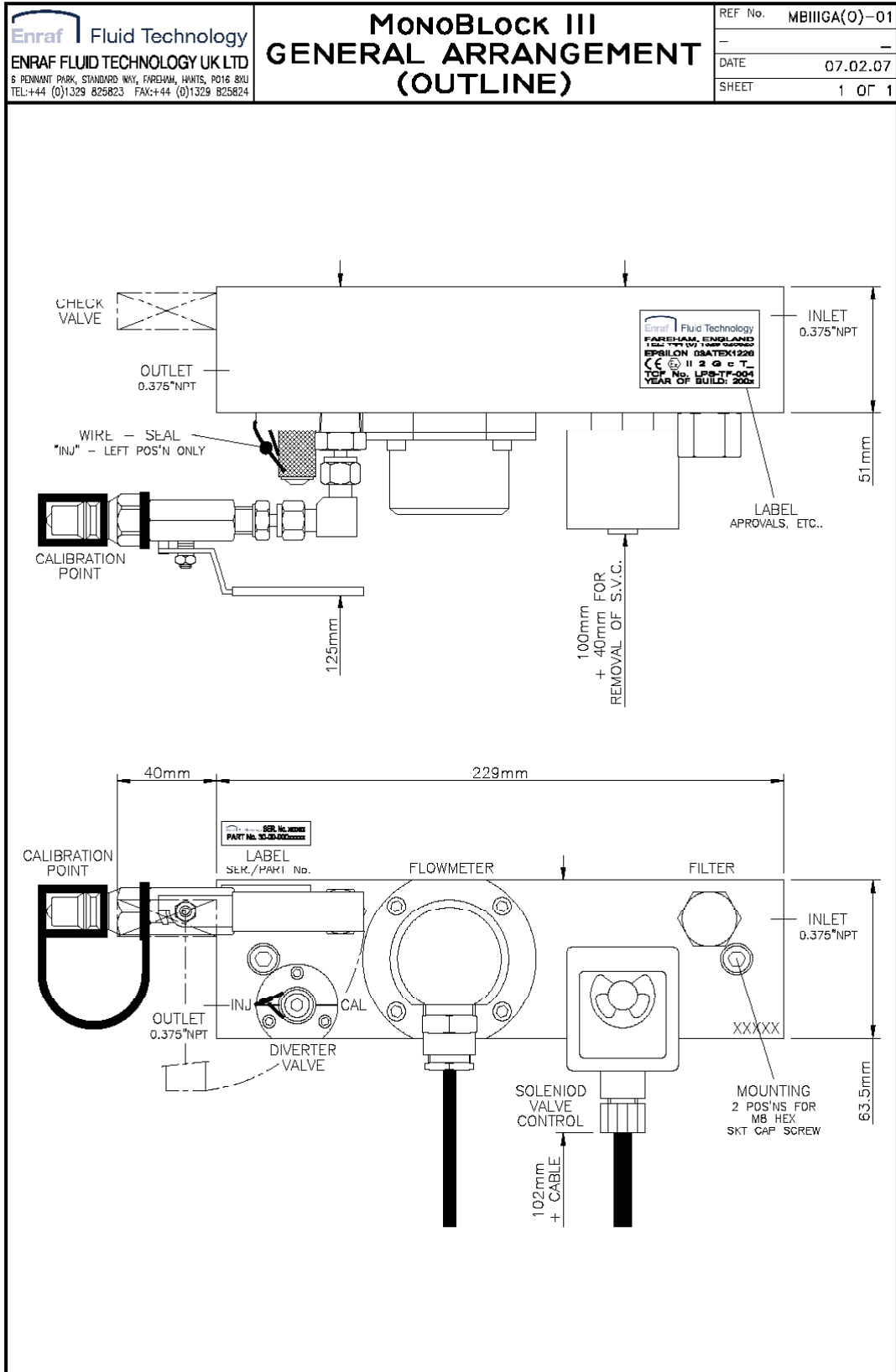

Intentionally left blank.

CHAPTER 6 ELECTRICAL CONNECTION DRAWINGS

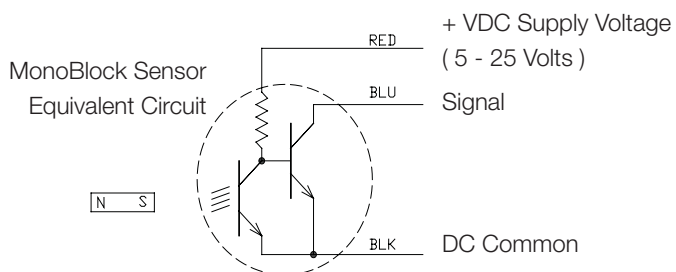

6.1 MONO-BLOCK™ III SENSOR LEAD IDENTIFICATION

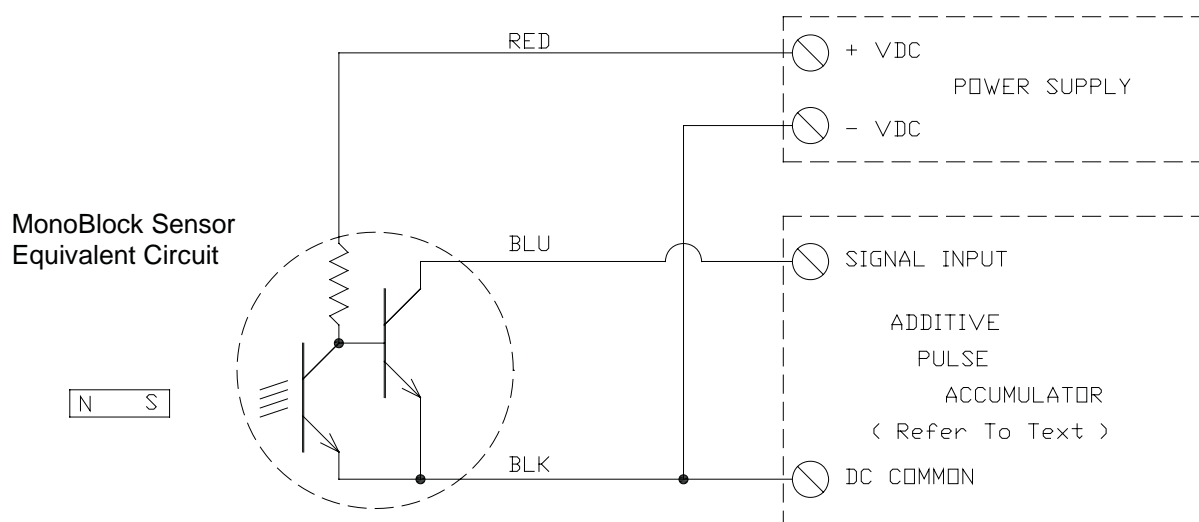

NOTES: The power supply pictured above may be a separate supply or part of the controller / additive pulse accumulator electronics.

6.2 WIRING DIAGRAM FOR SOURCED INPUTS

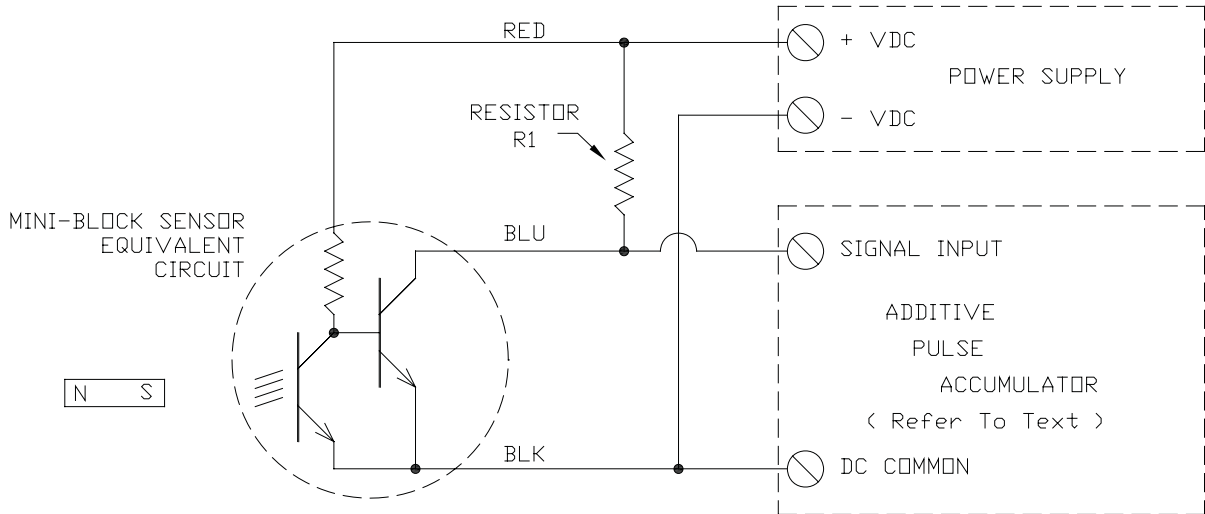

6.3 WIRING DIAGRAM FOR UN-SOURCED INPUTS

NOTES: The power supply pictured above may be a separate supply or part of the controller / additive pulse accumulator electronics.



Resistor R1 value varies with the Power Supply voltage.

For 5 - 12 volts use 1500 ohms.

For 12.1 - 18 volts use 2200 ohms.

For 18.1 - 25 volts use 2700 ohms.

For all voltages, ½ watt, 10% or better precision resistors are satisfactory.

CHAPTER 7 MONOBLOCK™ III STANDARD FEATURES

- 303 Stainless steel machined manifold block.
- 3/8" FNPT inlet and outlet connections machined into block.
- 3 GPM, 12Litres/min maximum flow rate through complete assembly.
- Oval gear meter machined into manifold block.
- High resolution gears 4800 pulses/gallon (1270 Pulses/Litre) output.
- Meter accuracy of 0.5%.
- Meter repeatability 0.25%.
- Oval Gear material Ryton.
- Gear pinion shafts of 18-8 Stainless Steel.
- Explosion proof hall-effect meter sensor.
- Sensor is 3-wire type with power (12VDC), common, and pulse signal connections.
- Sensor carries UL listing for Group I, Div I and ATEX approvals.
- UL or ATEX solenoid, machined into manifold block.
- Solenoid 120 VAC, 240 VAC, 24 VDC or 12 VDC powered.
- Built in calibration security diverter valve with integral flow control.
- Built-in strainer
- Built-in check valve
- 235 PSI, 16Bar max working pressure.
- 150 PSI, 10Bar max differential pressure.
- Solenoid is 303 SS construction.
- Solenoid 'Isolast' seat standard.
- Calibration port with standard quick disconnect coupler.

7.1 Optional Accessories

- Calibration kit, including quick-coupler (female), cylinder, back pressure check valve, and spout.
- Inlet and outlet isolation/flow control locking ball valves.
- Inlet and outlet QRC flushing connections.

Honeywell Enraf

6 Pennant Park
Standard Way
Fareham, UK PO16 8XU
United Kingdom
Tel: +44 1329 825 823
www.honeywell.com/ps

Honeywell Enraf