

PROTEGO® Pressure/Vacuum Relief Valves

end-of-line



Volume 5

Volume 5



for safety and environment

Function and Description

The function of pressure/vacuum valves for relief and conservation and the corresponding applications is discussed in „Technical Fundamentals“ (→ Vol. 1). In this chapter PROTEGO®'s product line of pressure/vacuum relief valves in end-of-line application is presented.

These are special devices that function as an **end-of-line valve** to protect against pressure and vacuum. The valves may be designed as pipe away version which can be connected to a vent header to process vapors.

Pressure relief valves prevent vapor loss up to the adjusted set pressure and offer reliable protection against excess pressure.

Vacuum relief valves prevent the unallowable entrance of air up to the adjusted set pressure and offer reliable protection against vacuum.

Pressure/vacuum relief valves perform all of the above tasks.

PROTEGO® pressure/vacuum disc relief valves have weight-loaded or spring-loaded valve pallets.

PROTEGO® pressure/vacuum relief valves with a full-lift disc discharge the volumetric flow within 10% overpressure from the set pressure up to full lift. After the response, the valve pallet immediately transitions to a full lift (Figs. 1 and 2).

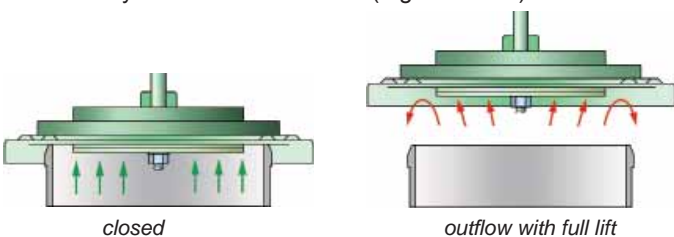

Fig. 1: Outflow with a full-lift disc and air cushion seal

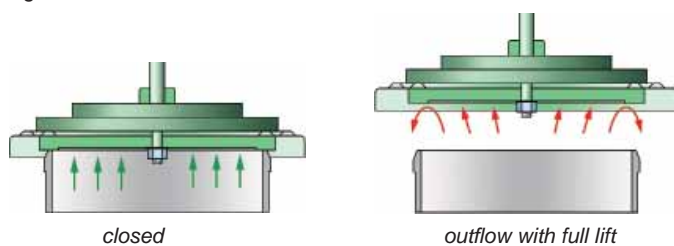

Fig. 2: Outflow with a full-lift disc and metal seal

This is attained by precisely harmonizing the diameter and height of the valve pallet rim with the adapted, lapped valve seat. In addition, a flow-enhancing design reinforces the overall effect on the outflow side. These valve pallets are used in end-of-line valves and in-line valves. The arrangement of valve pallet guidance and seal is combined in the term valve pallet.

Given the right size, the unique **10% technology** of the valves enables a set pressure that is just 10% below the maximum allowable tank pressure. For tanks with emergency relief vents the opening pressure of the relief valve needs to be below the set pressure of the emergency relief vent. The valve immediately opens to a full lift under a full load like a classic safety valve but in response to minimum changes in pressure. The full-lift discs are the result

of years of development. The ingenious engineering enables reliable valve pallet operation at a full load. The highly developed PROTEGO® manufacturing technology has produced a seal that is far superior to the conventional standard. This feature is supported by valve seats made of high-quality stainless steel and individually lapped valve pallets or valve seats with an air cushion seal, among other things.

Diaphragm valves are pressure/vacuum relief valves with a flexible diaphragm. Their special design is to satisfactorily handle problem products, even at extremely low temperatures below freezing, a thousand times over.

Special features and advantages

- Large flows with only a slight pressure drop
- Pressure setting close to the opening pressure (PROTEGO® 10% technology) for optimum retention of pressure in the system
- Seal superior to the normal standard values, which minimizes product loss
- The valve pallet is guided within the housing to protect against the weather

Preferred Applications

PROTEGO® pressure/vacuum relief valves are used as inbreathing and outbreathing valves, pressure relief valves, conservation valves, for simple control, and for venting tanks and equipment when an unallowable vacuum or pressure is exceeded. They are used for low pressures, e.g. in pressure ranges in which classic safety valves cannot be used due to their limited performance characteristics. PROTEGO® valves are available as pressure relief valves, vacuum relief valves, or as combined pressure/vacuum relief valves.

PROTEGO® **diaphragm valves** are used for problem products and low temperatures.

Pilot valves are advantageous for special control responses or when a tight seal is required up to the point at which the valve starts to open.

High-velocity-vent valves are used on tanker ships and for special land uses.

Installation and servicing

The valves come with detailed installation and servicing instructions.

Shipping braces are installed for safe transportation. Make sure that the transportation locks are removed before installing the valves. Startup checklists help to properly set up the valves for use.

Selection and sizing

To operate the system properly, the right valve is to be selected.

The criteria for selecting the right device are:

Function – a pressure relief valve, a vacuum relief valve, or a combined pressure/vacuum relief valve, with a pipe-away connection if needed.

Design – a combined end-of-line valve or separate pressure relief and vacuum relief valves with a perpendicular connection or horizontal connection. The devices are weight-loaded; therefore the valves are to be installed vertically.

The adjusted set pressure – the standard maximum allowable (tank) pressure minus 10% overpressure; it determines the combination of materials for the disc.

Type of seal – for disc valves according to the pressure level, either with an air cushion seal, or with a metal seal to provide an extremely tight seal.

Special operating conditions – for viscous and adhesive media, for frost-protected operation, or for use with polymerizing products.

The **nominal diameter** of the valve is generally determined by the connecting flange of the pipe, tank, or system part, or by the design specified in the performance diagram. To size a valve, the flow must be known for the overpressure output (outbreathing) and vacuum output (inbreathing). The nominal diameter or number of valves may have to be adjusted. Take into account potential system counterpressure when connecting a pipe.

Sizing

The **valve size** results from the volume flow which has to be vented to avoid an increase above the maximum allowable pressure or vacuum. Certified volume flow diagrams are used for sizing. For correct sizing the operating conditions and the pressure drops of the piping system (including other installed devices) and superimposed backpressures have to be taken into account.

Detailed procedures and examples for sizing are described in “Technical Fundamentals” (see Volume 1).

Example 1

Given: Volume flow \dot{V}_{\max} in m³/h / CFH (e.g. for in- or outbreathing of a storage tank this is the sum of the pump capacity and the thermal breathing requirement) and maximum allowable opening pressure (e.g. tank pressure) p_T in mbar / inch W.C.

Requested: Valve size DN

Procedure: The intersection point of \dot{V}_{\max} and p_T determines the required valve size. Opening pressure = the maximum allowable tank pressure. The volume flow diagrams show the volume flow as function of the opening pressure for a fully open valve.

The set pressure of the valve has to be determined so that the calculated volume flow can safely be discharged. For a valve

which needs 10% overpressure to reach full lift the set pressure may be chosen 10% below the fully open pressure (e.g. maximum allowable tank pressure). Attention: pressure drop of piping systems and other installed devices have to be considered!

Many conventional valves need 100% overpressure to reach full lift. In these cases the set pressure may be just half of the maximum allowable tank pressure. Consequently these valves open earlier and avoidable product losses occur.

Example 2

Alternatively the valve performance has to be checked if the size and maximum allowable pressure are provided.

Given: Connection nozzle size and maximum allowable opening pressure (e.g. tank pressure) p in mbar / inch W.C.

Required: Volume flow in m³/h / CFH, set pressure p_A in mbar / inch W.C.

Procedure: From the intersection point of the straight line of p and the valve performance curve of the specific valve size the volume flow \dot{V}_{\max} is determined. The volume flow of the set pressure p_A may be 10%, (PROTEGO® technology) or 40% or 100% below the opening pressure p_T . Attention: pressure drop of piping systems and other installed devices have to be considered!

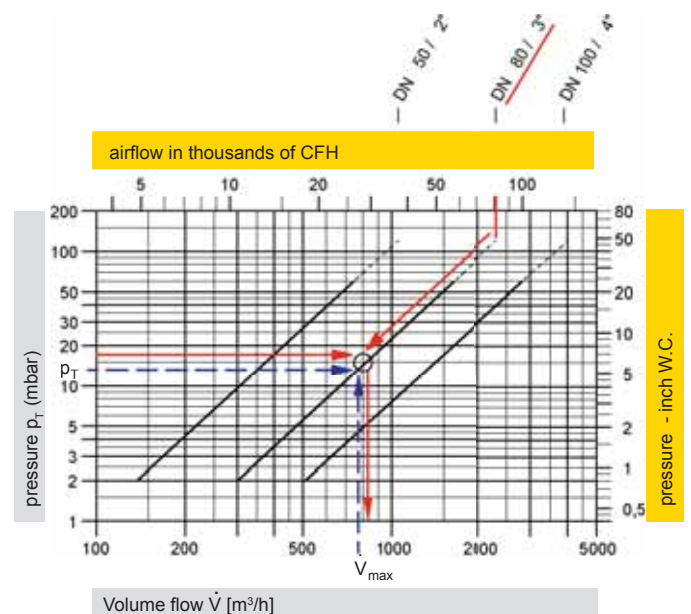

The required set pressure (= start of opening) will be the opening pressure (valve fully open) minus the characteristic overpressure.











For PROTEGO® valves and end of line devices the overpressure characteristic is 10% unless otherwise stated. Within 10% overpressure the valve pallet will reach full lift. A further increase in flow performance will follow the pressure volume flow diagram.



Material selection is based on plant and engineering specifications.



Selection Guide

PROTEGO® Pressure/Vacuum-Relief-Valves - end-of-line

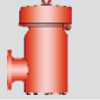
Image	Type	Size	pressure setting		Design O = horizontal connection X = vertical connection	O = soft sealing X = metallic sealing	O = for non-standard operating parameters	O = for critical Medium (Polymerisation, Corrosion, Crystallisation)	O = Heating jacket, Heating coil	Page
			positive setting range mbar / inch W.C.	negative setting range mbar / inch W.C.						
Pressure Relief Valves, weight pallet type										
	P/EL	50 - 80 2" - 3"	+3.5 up to +210/ +1.4 up to +84		X	O / X			O	176 - 177
	P/ELR	80 - 100 3" - 4"	+3.5 up to +210/ +1.4 up to +84		X	O / X			O	178 - 179
	SD/BS-H	80-200 3" - 8"	+5 up to +210/ +2 up to +84		X	X	O		O	180 - 181
	D/SVL	50-300 2" - 12"	+2.0 up to +60/ +0.8 up to +24		X	O / X				182 - 183
	ER-V-LP	200-700 8" - 28"	+3.4 up to +15/ +1.36 up to +6		X	O			O	184 - 185
	ER/VH	200-700 8" - 28"	DN 200-350: >+40 up to +60/ >+16 up to +24 DN 400-700: >+25 up to +60/ >+10 up to +24		X	O				186 - 187
	ER/V-F	200-700 8" - 28"	>+60 up to +500/ >+24 up to +200		X	O				188 - 189
	D/KSM	50-200 2" - 8"	+5.0 up to +100/ +2.0 up to +40		X	O	O	O		190 - 191
Vacuum Relief Valves, weight pallet type										
	SV/E-1-0	50 - 300 2" - 12"		-2.0 up to -60 / -0.8 up to -24	O	O / X			O	192 - 193
	SV/T-0-H	80 - 250 3" - 10"		-7.0 up to -50 / -2.8 up to -20	X	X	O		O	194 - 196
	V/KSM	50-200 2" - 8"		-5.0 up to -100 / -2.0 up to -40	O	O	O	O		198 - 199

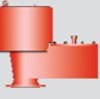
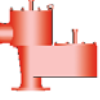
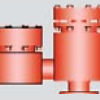
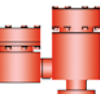
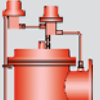
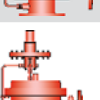
	Type	Size	pressure setting		Design O = horizontal connection X = vertical connection	O = soft sealing X = metallic sealing	O = for non-standard operating parameters	O = for critical Medium (Polymerisation, Corrosion, Crystallisation)	O = Heating jacket, Heating coil	Page
			positive setting range mbar / inch W.C.	negative setting range mbar / inch W.C.						
Pressure and Vacuum Relief Valves, weight pallet type										
	PV/EL	50 - 80 2" - 3"	+2.0 up to +210/ +0.8 up to +84	-3.5 up to -35 / -1.4 up to -14	O	O / X			O	200 - 202
	PV/ELR	80 - 100 3" - 4"	+2.0 up to +210/ +0.8 up to +84	-3.5 up to -50 / -1.4 up to -20	O	O / X			O	204 - 206
	VD/SV	40 - 300 1½" - 12"	+2.0 up to +60 / +0.8 up to +24	-2.0 up to -60 / -0.8 up to -24	X	O / X			O	208 - 210
	VD/SV-PA(L)	50 - 300 2" - 12"	+2.0 up to +60 / +0.8 up to +24	-2.0 up to -60 / -0.8 up to -24	X	O / X			O	212 - 215
	VD/KSM	50 - 200 2" - 8"	+5.0 up to +100 / +2.0 up to +40	-5.0 up to -100 / -2.0 up to -40	X	O	O	O		216 - 218
	VD/KSM-PA	50 - 200 2" - 8"	+5.0 up to +100 / +2.0 up to +40	-5.0 up to -100 / -2.0 up to -40	X	O	O	O		220 - 222
Pressure and Vacuum Relief Valves, pilot-operated										
	PM(D)S	80 - 300 3" - 12"	+10 up to +300 / +4.0 up to +120	-3.0 up to -7 / -1.2 up to -2.8	X	X	O			224 - 226
	PM-HF	80 - 300 3" - 12"	+10 up to +1034 / +4.0 up to +413.6	-2.2 up to -7 / -0.88 up to -2.8	X	X	O			228 - 230



Pressure Relief Valve

PROTEGO® P/EL

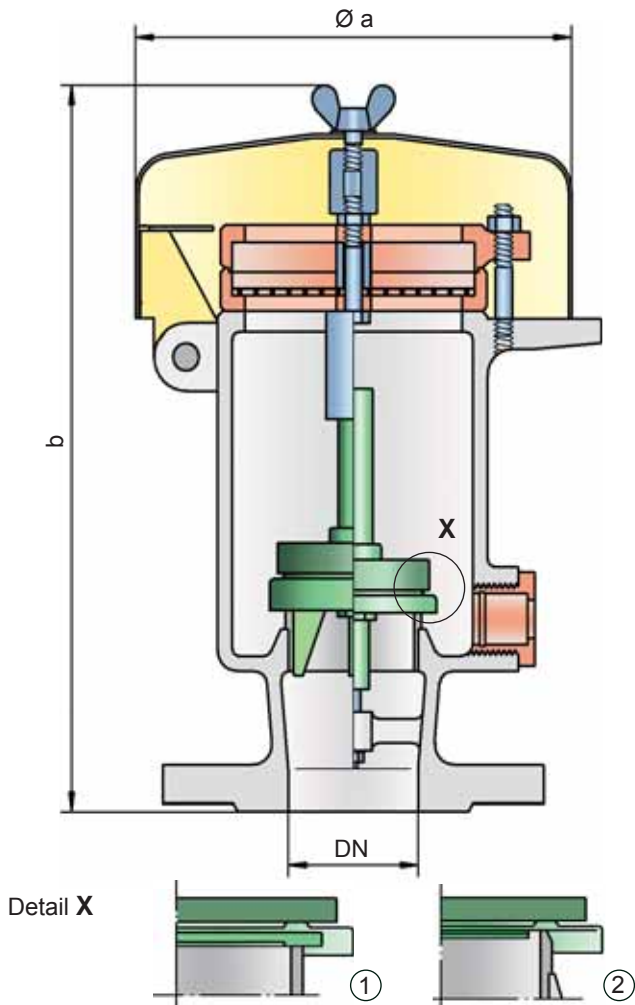

Pressure settings:

+3.5 mbar up to +210 mbar
 +1.4 inch W.C. up to +84 inch W.C.
 Higher pressure settings upon request.

Function and Description

The P/EL type PROTEGO® valve is a highly developed pressure relief valve. It is primarily used as a safety device for relieving pressure in tanks, containers and process engineering equipment. The valve protect against unallowable overpressure and prevents the unacceptable loss of product vapors close to the set pressure.

The device will start to open as soon as the set pressure is reached and only requires 10% overpressure to full lift. Continuous investments into research and development have al-

lowed PROTEGO® to develop a low pressure valve which has the same opening characteristic as a high pressure safety relief valve. This "full lift type" technology allows the valve to be set just 10% below the maximum allowable working pressure of the tank and still safely vent the required mass flow.

Due to our highly developed manufacturing technology the tank pressure is maintained up to set pressure, with a tightness that is far superior to the conventional standard. This feature is achieved by valve seats made of high quality stainless steel and with precisely lapped valve pallets (1) or with an air cushion seal (2) in conjunction with high quality FEP diaphragm. The valve pallets are also available with a PTFE seal to prevent the valve pallets from sticking when sticky products are used, and they enable the use of corrosive media. After the excess pressure is discharged, the valve reseats and provides a tight seal.

The optimized fluid dynamic design of the valve body and valve pallet is a result of many years of research work, which allow a stable operation of the valve pallet and optimized performance resulting in reduction of product losses.

Special Features and Advantages

- "full lift type" technology valve utilizes only 10% overpressure to reach full lift
- extreme tightness and hence least possible product losses and reduced environmental pollution
- the set pressure is close to the opening pressure which results in best possible pressure management of the system
- high flow capacity
- the valve pallet is guided within the housing to protect against harsh weather conditions
- can be used in areas subject to an explosion hazard
- self-actuated condensate drain

Design Types and Specifications

The valve pallet is weight-loaded. At set pressures greater than 80 mbar (32.1 inch W.C.), an elongated construction is used.

There are two different designs:

Pressure valve in basic design

P/EL -

Pressure valve with heating jacket

P/EL -

Additional special devices available upon request

Table 1: Dimensions

Dimensions in mm / inches

To select the nominal size (DN), use the flow capacity chart on the following page

DN	50 / 2"	50 / 2"	80 / 3"	80 / 3"
Set pressure	≤ +80 mbar ≤ +32.1 inch W.C.	> +80 mbar > +32.1 inch W.C.	≤ +80 mbar ≤ +32.1 inch W.C.	> +80 mbar > +32.1 inch W.C.
a	218 / 8.58	218 / 8.58	218 / 8.58	218 / 8.58
b	287 / 11.30	452 / 17.80	289 / 11.38	454 / 17.87

Dimensions for pressure valves with heating jacket upon request

Table 2: Material selection for housing

Design	B	C	Special materials upon request
Housing	Steel	Stainless Steel	
Heating jacket (P/EL-H-...)	Steel	Stainless Steel	
Valve seat	Stainless Steel	Stainless Steel	
Weather hood	Steel	Stainless Steel	
Protective mesh screen	Stainless Steel	Stainless Steel	

Table 3: Material selection for pressure valve pallet

Design	A	B	C	D	Special materials (Aluminum-coated, Titanium, Hastelloy) and higher pressure settings upon request
Pressure range (mbar) (inch W.C.)	+3.5 up to +5.0 +1.4 up to +2.0	>+5.0 up to +14 >+1.4 up to +5.6	>+14 up to +210 >+5.6 up to +84	>+14 up to +210 >+5.6 up to +84	
Valve pallet	Aluminium	Stainless Steel	Stainless Steel	Stainless Steel	
Sealing	FEP	FEP	Metal to Metal	PTFE	

Table 4: Flange connection type

EN 1092-1, Form B1 or DIN 2501, Form C, PN 16	EN or DIN	other types upon request
ANSI 150 lbs RFSF	ANSI	

Flow Capacity Chart

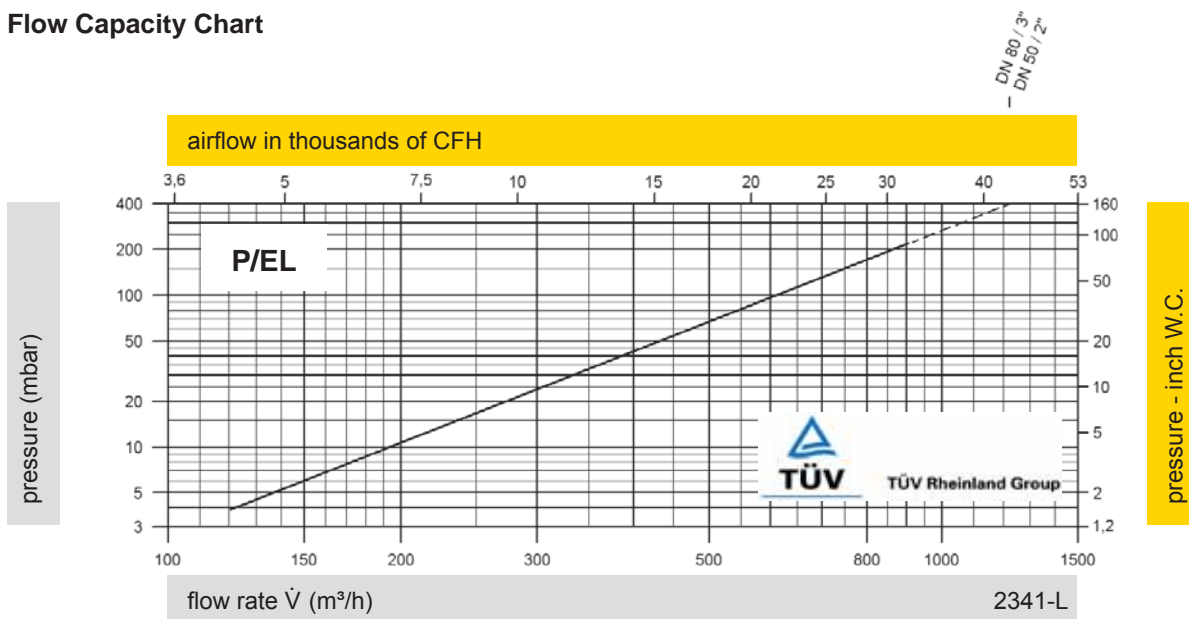

The flow capacity curve has been determined with a calibrated and TÜV certified flow capacity test rig. Volume flow \dot{V} in (m³/h) and CFH refer to the standard reference conditions of air ISO 6358 (20°C, 1bar). Conversion to other densities and temperatures refer to Vol. 1: "Technical Fundamentals".



for safety and environment



Pressure Relief Valve

PROTEGO® P/ELR

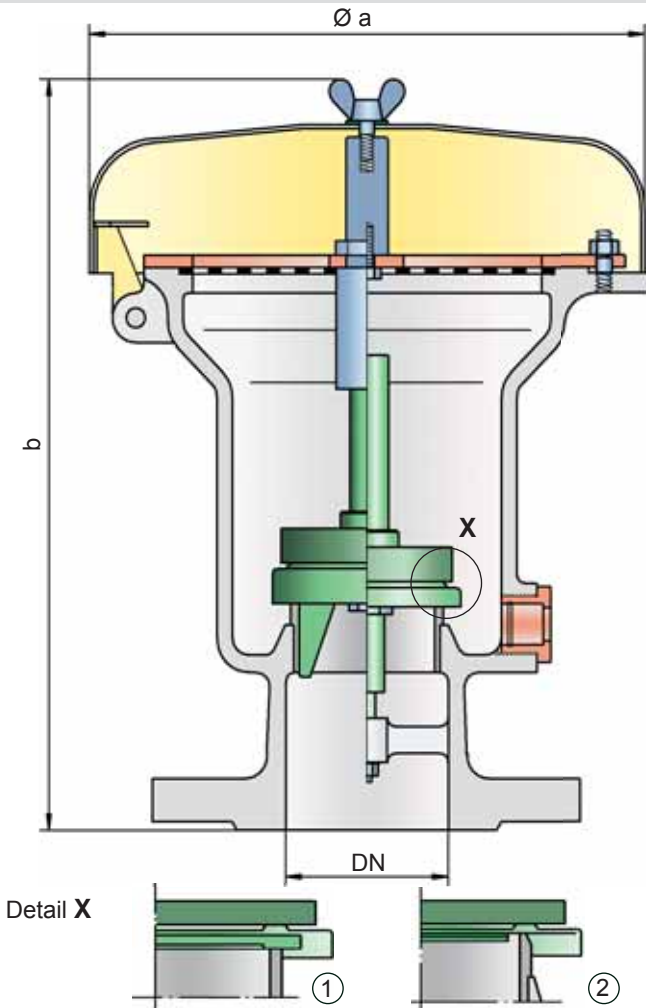

Pressure settings:

+3.5 mbar up to +210 mbar
 +1.4 inch W.C. up to +84 inch W.C.
 Higher pressure settings upon request.

Function and Description

The P/ELR type PROTEGO® valve is a highly developed pressure relief valve with excellent flow performance. It is primarily used as a safety device for relieving pressure in tanks, containers, and process engineering equipment. The valve offers reliable protection against overpressure and prevents the unacceptable loss of product vapors close to the set pressure.

The device will start to open as soon as the set pressure is reached and only requires 10% overpressure to full lift. Continuous investments into research and development have al-

lowed PROTEGO® to develop a low pressure valve which has the same opening characteristic as a high pressure safety relief valve. This "full lift type" technology allows the valve to be set just 10% below the maximum allowable working pressure of the tank and still safely vent the required mass flow.

Due to our highly developed manufacturing technology the tank pressure is maintained up to set pressure with a tightness that is far superior to the conventional standard. This feature is achieved by valve seats made of high quality stainless steel and with precisely lapped valve pallets (1) or with an air cushion seal (2) in conjunction with high quality FEP diaphragm. The valve pallets are also available with a PTFE seal to prevent the valve pallets from sticking when sticky products are used and to enable the use of corrosive fluids. After the excess pressure is discharged, the valve reseats and provides a tight seal.

The optimized fluid dynamic design of the valve body and valve pallet is a result of many years of research work, which allow a stable operation of the valve pallet and optimized performance resulting in reduction of product losses.

Special Features and Advantages

- "full lift type" technology valve utilizes only 10% overpressure to reach full lift
- extreme tightness and hence least possible product losses and reduced environmental pollution
- the set pressure is close to the opening pressure which results in best possible pressure management of the system
- high flow capacity
- the valve pallet is guided within the housing to protect against harsh weather conditions
- Can be used in areas subject to an explosion hazard
- self-actuated condensate drain

Design Types and Specifications

The valve pallet is weight-loaded. At set pressures greater than 80 mbar (32.1 inch W.C.), an elongated construction is used.

There are two different designs:

Pressure valve in basic design

P/ELR -

Pressure valve with heating jacket

P/ELR - H

Additional special devices available upon request

Table 1: Dimensions

Dimensions in mm / inches

To select the nominal size (DN), use the flow capacity chart on the following page

DN	80 / 3"	80 / 3"	100 / 4"	100 / 4"
Set pressure	≤ +80 mbar ≤ +32.1 inch W.C.	> +80 mbar > +32.1 inch W.C.	≤ +80 mbar ≤ +32.1 inch W.C.	> +80 mbar > +32.1 inch W.C.
a	353 / 13.90	353 / 13.90	353 / 13.90	353 / 13.90
b	345 / 13.58	505 / 19.88	345 / 13.58	505 / 19.88

Dimensions for pressure valves with heating jacket upon request

Table 2: Material selection for housing

Design	B	C	Special materials upon request
Housing	Steel	Stainless Steel	
Heating jacket (P/ELR-H-...)	Steel	Stainless Steel	
Valve seat	Stainless Steel	Stainless Steel	
Weather hood	Steel	Stainless Steel	
Protective mesh screen	Stainless Steel	Stainless Steel	

Table 3: Material selection for pressure valve pallet

Design	A	B	C	D	Special materials (Aluminum-coated, Titanium, Hastelloy) and higher pressure settings upon request
Pressure range (mbar) (inch W.C.)	+3.5 up to +5.0 +1.4 up to +2.0	>+5.0 up to +14 >+1.4 up to +5.6	>+14 up to +210 >+5.6 up to +84	>+14 up to +210 >+5.6 up to +84	
Valve pallet	Aluminium	Stainless steel	Stainless steel	Stainless steel	
Sealing	FEP	FEP	Metal to Metal	PTFE	

Table 4: Flange connection type

EN 1092-1, Form B1 or DIN 2501, Form C, PN 16	EN or DIN	other types upon request
ANSI 150 lbs RFSF	ANSI	

Flow Capacity Chart

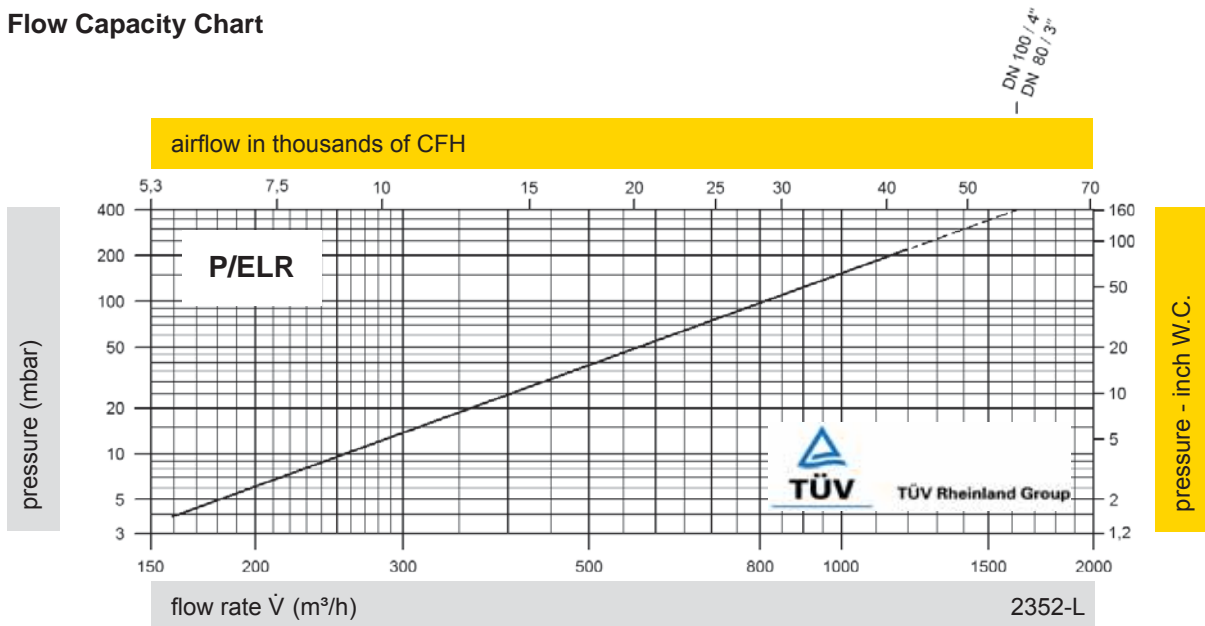

The flow capacity chart has been determined with a calibrated and TÜV certified flow capacity test rig. Volume flow \dot{V} in (m³/h) and CFH refer to the standard reference conditions of air ISO 6358 (20°C, 1bar). Conversion to other densities and temperatures refer to Vol. 1: "Technical Fundamentals".





Pressure Relief Valve in heat jacketed design

PROTEGO® SD/BS-H

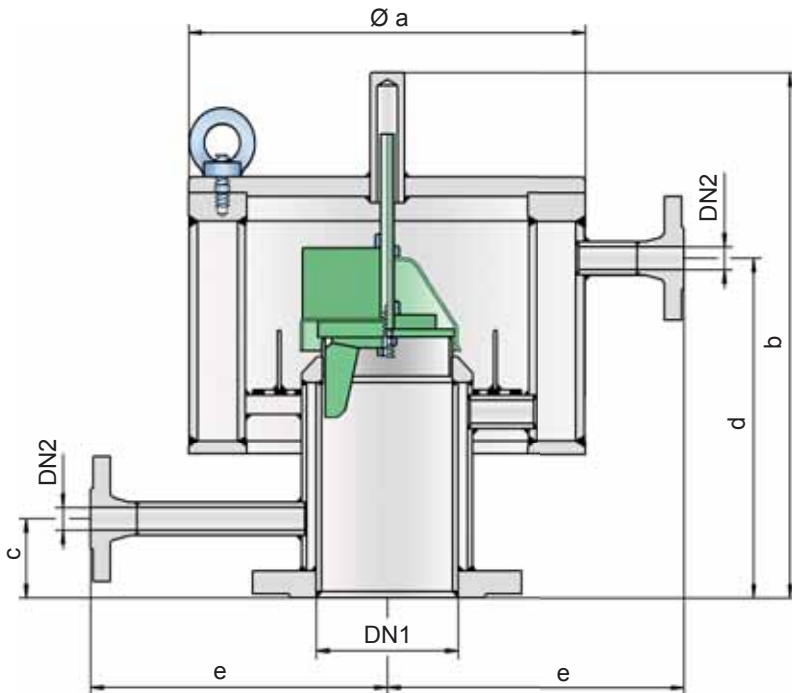

Due to our highly developed manufacturing technology the tank pressure is maintained up to set pressure, with a tightness that is far superior to the conventional standard. This feature is achieved by valve seats made of high-grade stainless steel with precisely lapped valve pallets and a reinforced housing design. After the excess pressure is discharged, the valve reseats and provides a tight seal again.

Special Features and Advantages

- “full lift type” technology valve utilizes only 10% overpressure to reach full lift
- extreme tightness and hence least possible product losses and reduced environmental pollution
- set pressure is close to the opening pressure which results in best possible pressure management of the system
- high flow capacity
- the valve pallet is guided within the housing to protect against harsh weather conditions
- can be used in areas subject to an explosion hazard
- heating jacketed design down to the flange to avoid cold bridges
- maximum permissible heating medium temperature of 320°C / 608°F (at 6 bar / 87 psi)
- a special design with a heatable valve cover is available
- at low pressure settings, an optimized valve pallet cover prevents the set pressure from being distorted by dust or condensate
- reinforced housing design
- a special design with a mechanical vent pallet lift device is available

Pressure Settings:

+5.0 mbar up to +210 mbar
+2.0 inch W.C. up to +84 inch W.C.
Higher pressure settings upon request.

Function and Description

The SD/BS-H type PROTEGO® valve is a highly developed pressure relief valve with a heating jacket down to the flange. It is primarily used as pressure relief device for vessels and process engineering equipment under difficult operating conditions. This includes extreme weather conditions or products that tend to form polymers at certain temperatures, adhere, or form deposits that negatively influence function (such as bitumen, tar, dust). The valve offers reliable protection against overpressure and prevents the unacceptable loss of product vapors close to the set pressure.

The device will start to open as soon as the set pressure is reached and only requires 10% overpressure to full lift. Continuous investments into research and development have allowed PROTEGO® to develop a low pressure valve which has the same opening characteristic as a high pressure safety relief valve. This “full lift type” technology allows the valve to be set just 10% below the maximum allowable working pressure of the tank and still safely vent the required mass flow.

Design Types and Specifications

The valve pallet is weight-loaded. Starting at a set pressure of 30 mbar, a vane guide is also used.

Pressure valve in basic design with heating jacket **SD/BS - H**

Additional special devices available upon request

Table 1: Dimensions

Dimensions in mm / inches

To select the nominal size (DN), use the flow capacity chart on the following page

DN1	DN2	a	b		c	d		e
			≤ 30 mbar ≤12 inch W.C.	> 30 mbar >12 inch W.C.		≤ 30 mbar ≤12 inch W.C.	> 30 mbar >12 inch W.C.	
80 / 3" *	15 / ½"	325 / 12.80	400 / 15.75	515 / 20.28	70 / 2.76	250 / 9.84	390 / 15.35	250 / 9.84
100 / 4"	15 / ½"	325 / 12.80	400 / 15.75	505 / 19.88	60 / 2.36	250 / 9.84	380 / 14.96	250 / 9.84
150 / 6"	15 / ½"	405 / 15.94	460 / 18.11	595 / 23.43	60 / 2.36	315 / 12.40	470 / 18.50	290 / 11.42
200 / 8"	15 / ½"	510 / 20.08	470 / 18.50	575 / 22.64	65 / 2.56	305 / 12.01	445 / 17.52	340 / 13.39

* also available with special flange DN 50 / 2"

Table 2: Material selection for housing

Design	A	B	
Housing	Steel	Stainless Steel	Special materials upon request
Heating Jacket	Steel	Stainless Steel	
Valve Seat	Stainless Steel	Stainless Steel	

Table 3: Material selection for pressure valve pallet

Design	A	B	C	
Pressure range (mbar) (inch W.C.)	+5 up to +25 +2 up to +10	>+10 up to +30 >+4 up to +12	>+30 up to +210 >+12 up to +84	Special materials and higher pressure settings upon request
Valve pallet	Aluminium	Stainless Steel	Stainless Steel	
Valve pallet hood	Stainless Steel	Stainless Steel	-	
Sealing	Metal to Metal	Metal to Metal	Metal to Metal	

Table 4: Flange connection type

EN 1092-1, Form B1 or DIN 2501, Form C, PN 16; from DN 200 PN 10	EN or DIN	other types upon request
ANSI 150 lbs RFSF	ANSI	

Flow Capacity Chart

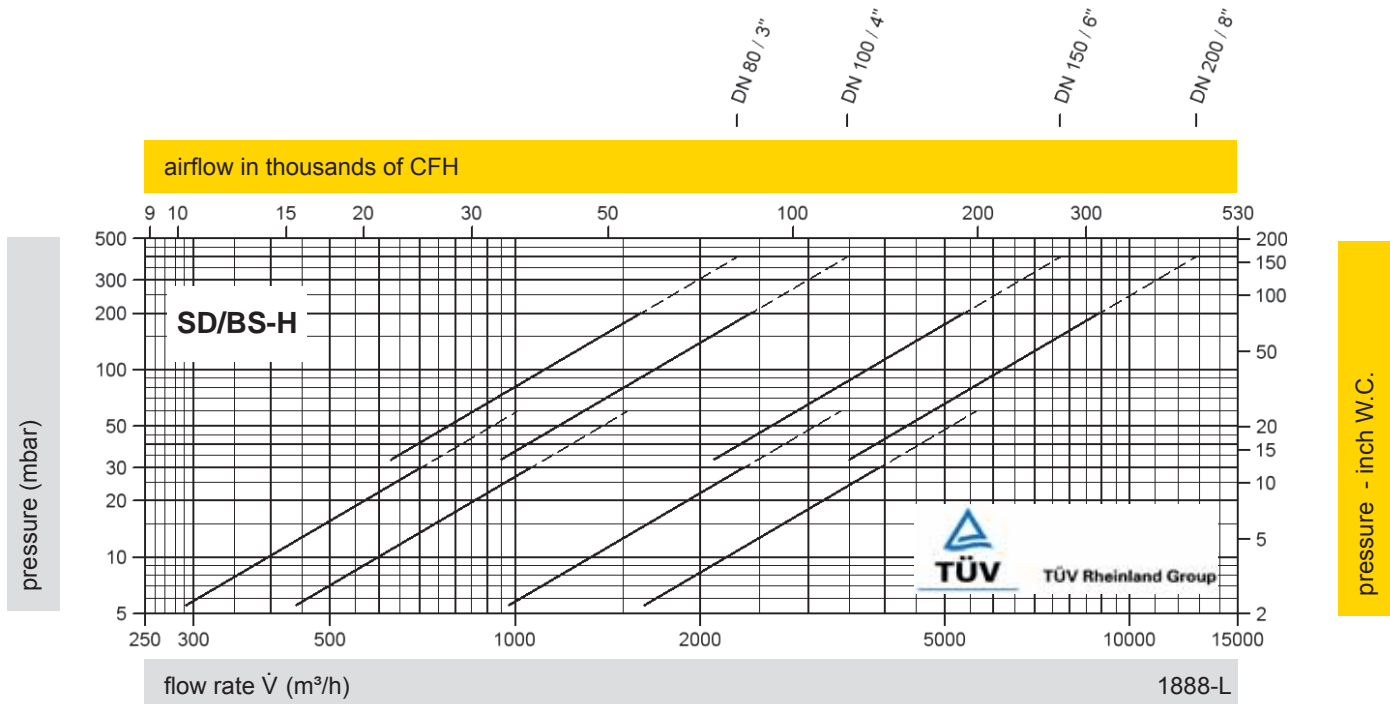

The flow capacity chart has been determined with a calibrated and TÜV certified flow capacity test rig. Volume flow \dot{V} in (m³/h) and CFH refer to the standard reference conditions of air ISO 6358 (20°C, 1bar). Conversion to other densities and temperatures refer to Vol. 1: "Technical Fundamentals".



for safety and environment



Pressure Relief Valve

PROTEGO® D/SVL

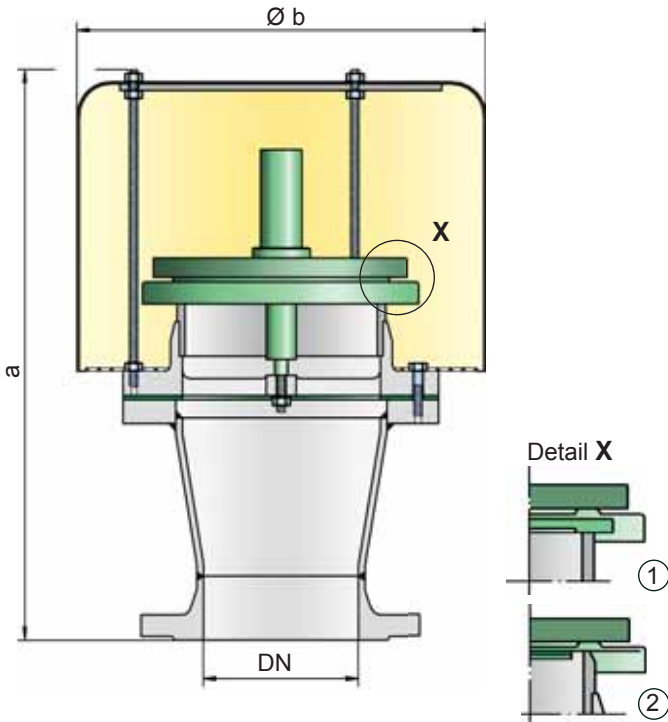

Pressure settings:

+2.0 mbar up to +60 mbar
 +0.8 inch W.C. up to +24 inch W.C.
 Higher pressure settings upon request.

Function and Description

The D/SVL type PROTEGO® valve is a high performance pressure relief valve. It is primarily used as a safety device for relieving pressure in tanks, containers, and process engineering equipment. The valve offers reliable protection against overpressure and prevents the unacceptable loss of product vapors close to the set pressure.

The device will start to open as soon as the set pressure is reached and only requires 10% overpressure to full lift. Continuous investments into research and development have allowed PROTEGO® to develop a low pressure valve which has

the same opening characteristic as a high pressure safety relief valve. This “full lift type” technology allows the valve to be set just 10% below the maximum allowable working pressure of the tank and still safely vent the required mass flow.

Due to the highly developed manufacturing technology, the tank pressure is maintained up to the set pressure, with a tightness that is far superior to the conventional standard. This feature is achieved by valve seats made of high quality stainless steel and with precisely lapped valve pallets (1) or with an air cushion seal (2) in conjunction with high quality FEP diaphragm. The valve pallets are also available with a PTFE seal to prevent the valve pallet from sticking when sticky products are used, and they enable the use of corrosive media. After the excess pressure is discharged, the valve reseats and provides a tight seal again.

The optimized fluid dynamic design of the valve body and valve pallet is a result of many years of research work, which allow a stable operation of the valve pallet and optimized performance resulting in reduction of product losses.

Special Features and Advantages

- “full lift type” valve utilizes only 10% overpressure to reach full lift
- extreme tightness and hence least possible product losses and reduced environmental pollution
- the set pressure is close to the opening pressure which results in best possible pressure management of the system
- extremely high flow capacity
- the valve pallet is guided within the housing to protect against harsh weather conditions
- can be used in areas subject to an explosion hazard

Design Types and Specifications

The valve pallet is weight-loaded. Higher pressures can be achieved upon request with a special spring-loaded design.

Pressure valve in basic design

D/SVL -

Additional special devices available upon request

Table 1: Dimensions

Dimensions in mm / inches

To select the nominal size (DN), use the flow capacity chart on the following page

DN	50 / 2"	80 / 3"	100 / 4"	150 / 6"	200 / 8"	250 / 10"	300 / 12"
a	336 / 13.23	412 / 16.22	444 / 17.48	564 / 22.20	664 / 26.20	687 / 27.05	687 / 27.05
b	200 / 7.87	295 / 11.61	295 / 11.61	465 / 18.31	550 / 21.65	650 / 25.59	650 / 25.59

Table 2: Material selection for housing

Design	A	B
Housing	Steel	Stainless Steel
Valve seat	Stainless Steel	Stainless Steel
Sealing	PTFE	PTFE
Weather hood	Stainless Steel	Stainless Steel

Special Materials upon request

Table 3: Material selection for pressure valve pallet

Design	A	B	C	D	E	F
Pressure (mbar)	+2.0 up to +3.5	>+3.5 up to +14	>+14 up to +35	>+35 up to +60	>+14 up to +35	>+35 up to +60
range (inch W.C.)	+0.8 up to +1.4	>+1.4 up to +5.6	>+5.6 up to +14	>+14 up to +24	>+5.6 up to +14	>+14 up to +24
Valve	Aluminium	Stainless steel	Stainless steel	Stainless steel	Stainless steel	Stainless steel
Sealing	FEP	FEP	Metal to Metal	Metal to Metal	PTFE	PTFE

Special Materials and higher pressure settings upon request

Table 4: Flange connection type

EN 1092-1, Form B1 or DIN 2501, Form C, PN 16; from DN 200 PN 10	EN or DIN
ANSI 150 lbs RFSF	ANSI

other types upon request

Flow Capacity Chart

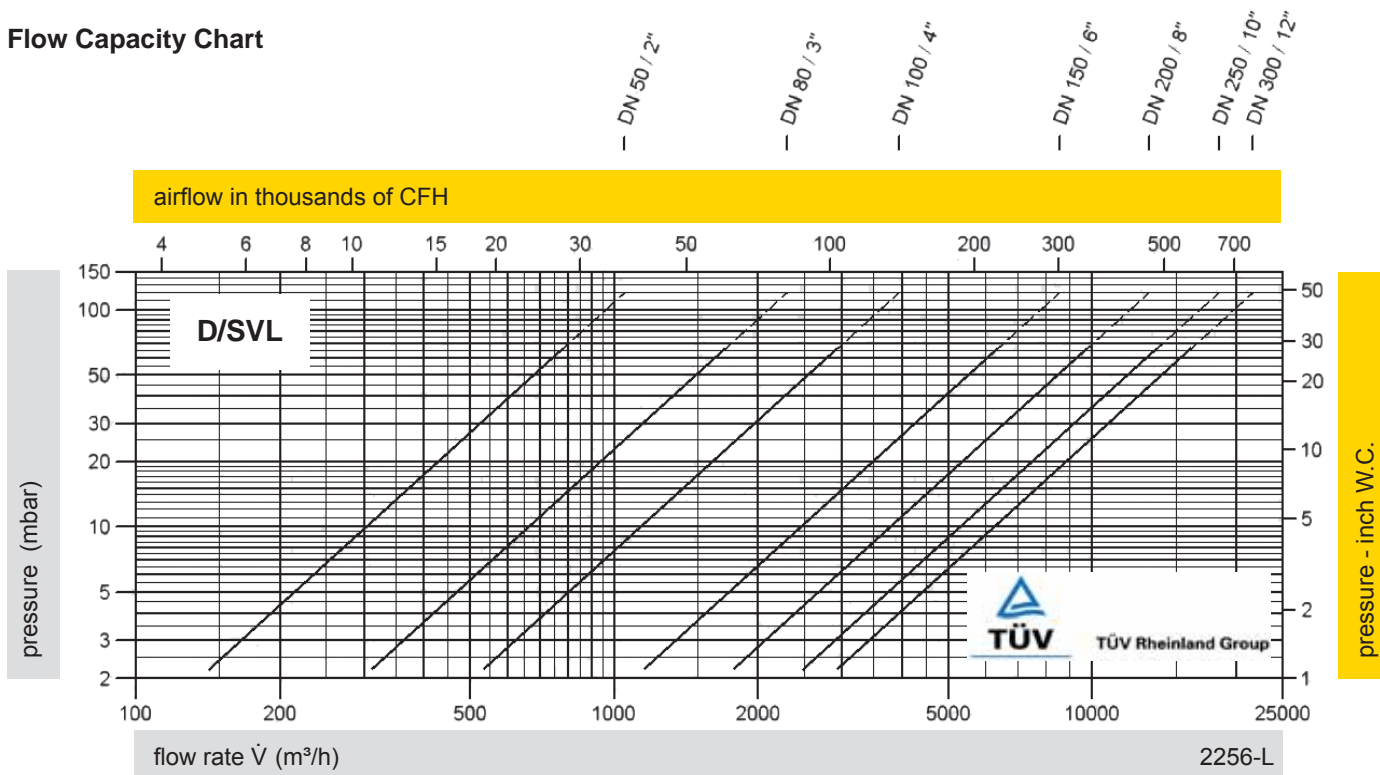

The flow capacity chart has been determined with a calibrated and TÜV certified flow capacity test rig. Volume flow \dot{V} in (m³/h) and CFH refer to the standard reference conditions of air ISO 6358 (20°C, 1bar). Conversion to other densities and temperatures refer to Vol. 1: "Technical Fundamentals".



for safety and environment



Emergency pressure relief valve

PROTEGO® ER-V-LP

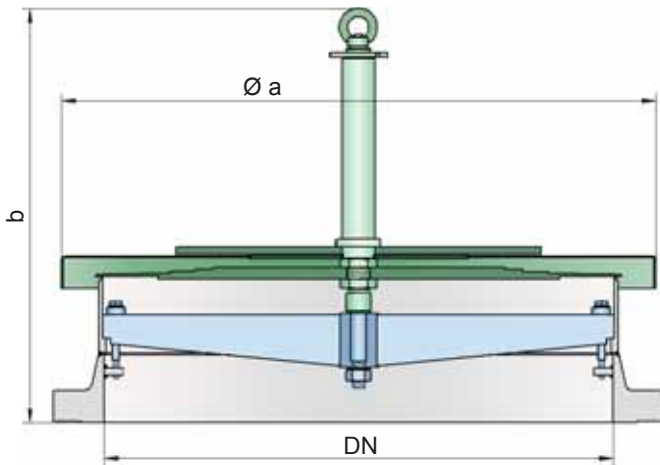

Pressure Settings:

+3.4 mbar up to +15 mbar
 +1.4 inch W.C. up to +6 inch W.C.

For higher pressure settings, see types ER/V, ER/VH and ER/V-F.

Function and Description

The PROTEGO® Type ER-V-LP valve is a sophisticated pressure relief valve for applications in which a high flow efficiency is of the essence. It is primarily used as an emergency pressure relief valve on storage tanks, vessels, silos, and process engineering equipment; it offers reliable protection against excessive overpressure and prevents excessive product loss at pressures as high as close to the set-to-operate pressure. It is designed to relieve particularly large quantities to prevent the vessel rupturing in an emergency case.

The valve will start to open as soon as the set-to-operate pressure is reached and only requires a 10% pressure increase or opening pressure differential until full lift. Dedicated R & D investments have enabled PROTEGO® to develop a new *valve pallet technology* for which a patent has been granted. This patented *valve pallet technology* allows the area characteristic typical of safety valves to be also applied to lower-pressure applications, while ensuring that minimum leakage-rate requirements are met.

Adopting this new patented *valve pallet technology* permits the valve to be set to just 10% below the maximum allowable working pressure of the tank and still vent the required mass flow.

Due to the sophisticated manufacturing technology, the tank pressure is maintained up to the set-to-operate pressure, with seal-tight requirements far above common standards being met. Once the excess pressure is relieved, the valve reseats and seals tight again.

Special Features and Advantages

- patented *valve pallet technology* guarantees that minimum leakage-rate requirements can be met and, hence, least possible product losses and reduced impact on the environment are ensured
- 10% Technology for minimum pressure increase until full lift
- set-to-operate pressure close to the opening pressure; hence, best possible pressure management of the system
- high flow efficiency
- valve pallet is guided within a closed system and, thus, protected from atmospheric influence
- suited for use in hazardous areas
- rugged body design
- movable components are secured
- best technology for API tanks

Design Types and Specifications

The valve pallet is weight-loaded. Higher set-to-operate pressures are achieved with Types ER/V and ER/VH (lever-operated) valves or Type ER/V-F (spring-loaded) valves.

Pressure valve in basic design

ER-V-LP

Additional special devices available upon request

Table 1: Dimensions

Dimensions in mm / inches

To select the nominal size (DN), use the flow capacity chart on the following page

DN	200 / 8"	250 / 10"	300 / 12"	350 / 14"	400 / 16"	450 / 18"	500 / 20"	600 / 24"	700 / 28"
a	343 / 13.50	406 / 15.98	483 / 19.02	533 / 20.98	597 / 23.50	635 / 25.00	699 / 27.52	813 / 32.01	837 / 32.95
b	378 / 14.88	399 / 15.71	409 / 16.10	440 / 17.32	455 / 17.91	464 / 18.27	481 / 18.94	556 / 21.89	571 / 22.48

Table 2: Material selection

Design	A	B	Special Materials upon request
Housing	Steel	Stainless Steel	
Valve seat	Stainless Steel	Stainless Steel	
Valve pallet	Stainless Steel	Stainless Steel	
Sealing	Stainless Steel	Stainless Steel	

Table 3: Flange connection type

EN 1092-1, Form B1 or DIN 2501, Form C, PN 10	EN or DIN	other types upon request
ANSI 150 lbs RFSF	ANSI	

Flow Capacity Chart

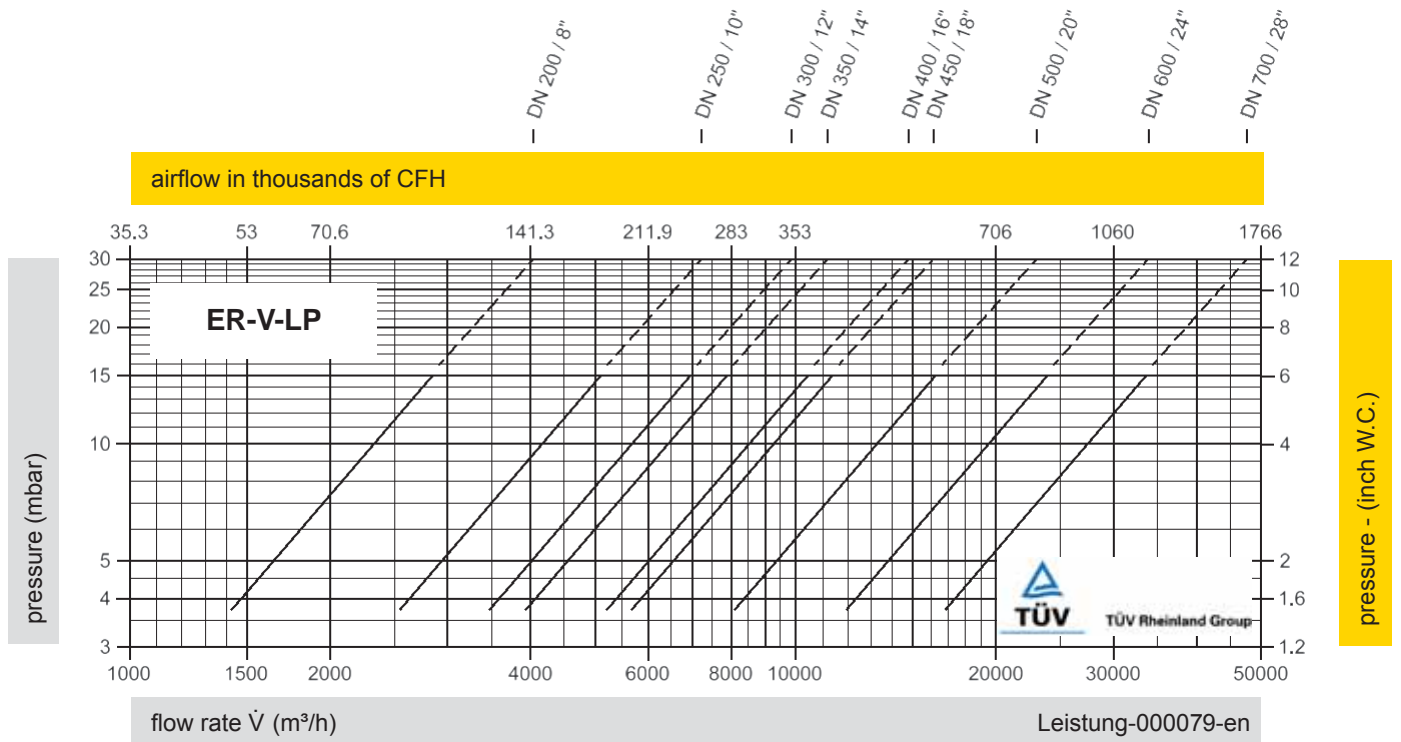

The flow capacity chart has been determined with a calibrated and TÜV certified flow capacity test rig. Volume flow \dot{V} in (m³/h) and CFH refer to the standard reference conditions of air ISO 6358 (20°C, 1bar). Conversion to other densities and temperatures refer to Vol. 1: "Technical Fundamentals".



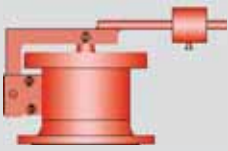

Pressure Relief Valve

PROTEGO® ER/VH

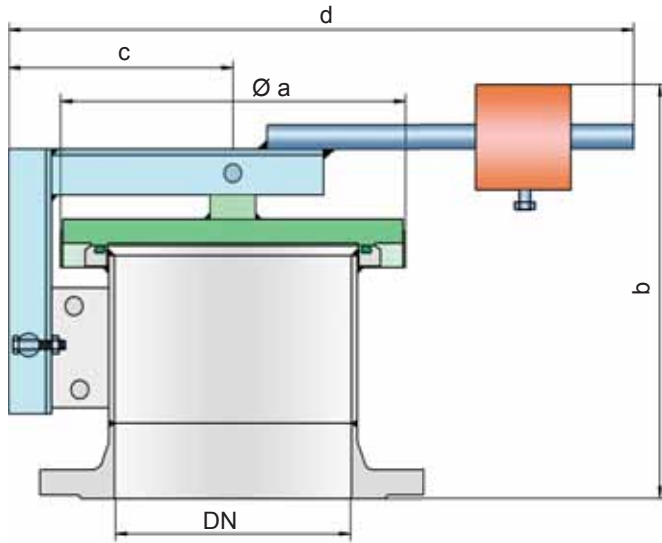

Pressure settings:

DN 200 to DN 350:	>+40 mbar	up to +60 mbar
	>+16 inch W.C.	up to +24 inch W.C.
DN 400 to DN 700:	>+25 mbar	up to +60 mbar
	>+10 inch W.C.	up to +24 inch W.C.

Higher and lower pressure settings, upon request.

Function and Description

The ER/VH type PROTEGO® valve is a highly developed emergency pressure relief valve with high flow capacity. It is primarily used as a safety device for emergency pressure relief for storage tanks, containers, silos, and process engineering equipment; it offers reliable protection against overpressure and prevents impermissible product vapor loss close to the set pressure. It is designed to discharge particularly large amounts to prevent the vessel from rupturing in an emergency case. Higher set pressures are achieved by a lever with lockable weight loading. The position of the weight is factory-marked. Starting at DN 500, the devices can also be used as manhole covers.

When the set pressure is reached, the valve starts to open and is fully open within 10% overpressure. This unique 10% "full lift type technology" enables a pressure setting that is only 10% below the maximum allowable working pressure or design pres-

sure of the tank. Even in the low pressure range the vent has the opening characteristic comparable to a typical high pressure safety relief valve. The full lift type pallets are a result of many years of development. The valve pallet is mounted on one side.

Due to the highly developed manufacturing technology, the tank pressure is maintained up to the set pressure, with a tightness that is far superior to the conventional standard. This feature is achieved by valve seats made of stainless steel with an inserted O-ring seal, a precisely lapped valve pallet, as well as a reinforced housing design. After the excess pressure is discharged, the valve reseats and provides a tight seal again.

Special Features and Advantages

- "full lift type" technology valve utilizes only 10% overpressure to reach full lift
- excellent tightness and hence least possible product losses and reduced environmental pollution
- the set pressure is close to the opening pressure which results in best possible pressure management of the system
- high flow capacity
- can be used in areas subject to explosion hazards
- reinforced housing design
- safely secured housing cover
- best technology for API-tanks

Design Types and Specifications

The valve pallet is weight-loaded. Lower pressures are generally achieved without a lever design (see ER-V-LP, ER/V), and higher pressures are realized with spring-loading (see ER/V-F).

Pressure valve in basic design

ER/VH

Additional special devices available upon request

Table 1: Dimensions

Dimensions in mm / inches

To select the nominal size (DN), use the flow capacity chart on the following page

DN	200 / 8"	250 / 10"	300 / 12"	350 / 14"	400 / 16"	450 / 18"	500 / 20"	600 / 24"	700 / 28"
a	305 / 12.01	375 / 14.76	425 / 16.73	445 / 17.52	495 / 19.49	545 / 21.46	615 / 24.21	715 / 28.15	795 / 31.30
b	350 / 13.78	365 / 14.37	385 / 15.16	390 / 15.35	390 / 15.35	415 / 16.34	420 / 16.53	450 / 17.72	465 / 18.31
c	200 / 7.87	240 / 9.45	265 / 10.43	285 / 11.22	310 / 12.20	330 / 12.99	360 / 14.17	410 / 16.14	450 / 17.72
d	590 / 23.23	735 / 28.94	780 / 30.71	845 / 33.27	890 / 35.04	1070 / 42.13	1090 / 42.91	1140 / 44.88	1380 / 54.33

Table 2: Material selection

Design	A	B
Housing	Steel	Stainless Steel
Valve seat	Stainless Steel	Stainless Steel
Valve pallet	Stainless Steel or Steel-Stainless Steel	Stainless Steel
Sealing	FPM	FPM
Weight	Steel	Stainless Steel

Special materials upon request

Table 3: Flange connection type

EN 1092-1, Form B1 or DIN 2501, Form C, PN 10	EN or DIN
ANSI 150 lbs RFSF	ANSI

other types upon request

Flow Capacity Chart

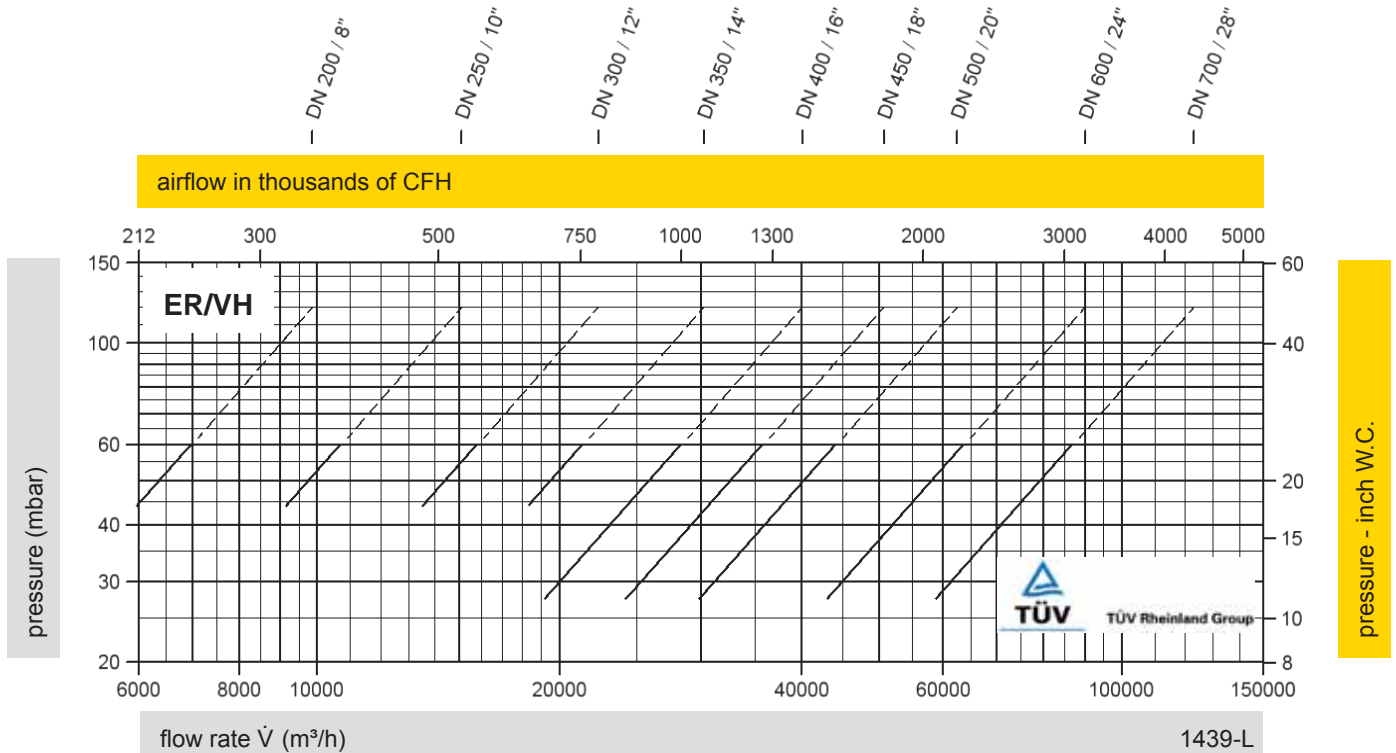

The flow capacity chart has been determined with a calibrated and TÜV certified flow capacity test rig. Volume flow \dot{V} in (m³/h) and CFH refer to the standard reference conditions of air ISO 6358 (20°C, 1bar). Conversion to other densities and temperatures refer to Vol. 1: "Technical Fundamentals".



for safety and environment



Pressure Relief Valve

PROTEGO® ER/V-F

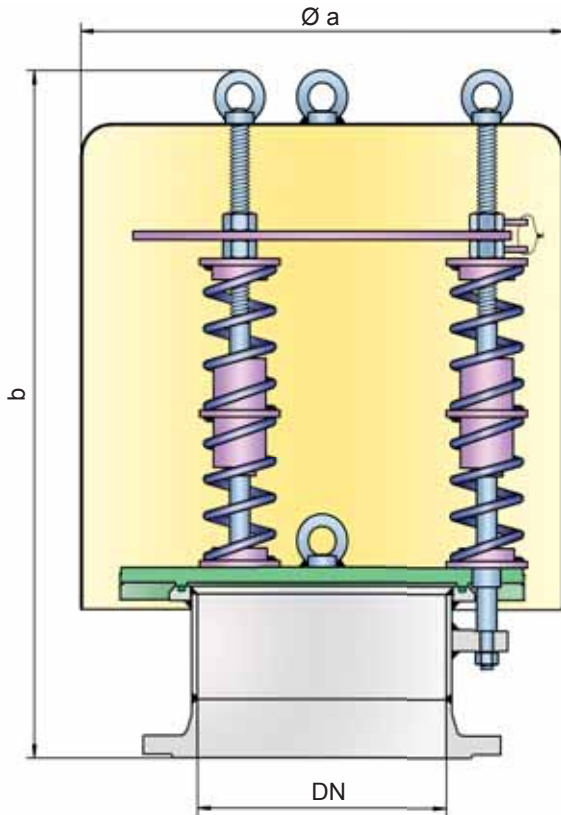

Pressure settings:

>+60 mbar up to +500 mbar

>+24 inch W.C. up to +200 inch W.C.

Higher pressure settings, upon request.

Lower pressure settings, see types ER-V-LP, ER/V and ER/VH.

Function and Description

The ER/V-F type PROTEGO® valve is a highly developed emergency pressure relief valve with high flow capacity. It is primarily used as a safety device for emergency pressure relief for storage tanks, containers, silos, and process engineering equipment; it offers reliable protection against overpressure and prevents impermissible product vapor loss close to the set pressure. It is designed to discharge particularly large amounts to prevent the vessel from rupturing in an emergency case. The spring-loading allows for higher set pressures than those with the ER-V-LP, ER/V or ER/VH.

The device will start to open as soon as the set pressure is reached and only requires 10% overpressure to full lift. Continuous investments into research and development have allowed PROTEGO® to develop a low pressure valve which has the same opening characteristic as a high pressure safety relief valve. This “full lift type” technology allows the valve to be set just 10% below the maximum allowable working pressure of the tank and still safely vent the required mass flow.

Due to the highly developed manufacturing technology, the tank pressure is maintained up to the set pressure, with a tightness that is far superior to the conventional standard. This feature is achieved by valve seats made of high-grade steel with an inserted O-ring seal, a precisely lapped valve pallet, as well as a reinforced housing design. After the excess pressure is relieved, the valve reseats and provides a tight seal again.

Special Features and Advantages

- “full lift type” technology valve utilizes only 10% overpressure to reach full lift
- excellent tightness and hence least possible product losses and reduced environmental pollution
- the set pressure is close to the opening pressure which results in best possible pressure management of the system
- high flow capacity
- the valve pallet is guided within the housing to protect against harsh weather conditions
- can be used in areas subject to explosion hazards
- reinforced housing design
- spring-loading for high set pressures
- best technology for API-tanks

Design Types and Specifications

The valve pallet is spring-loaded. Lower pressures are achieved with the ER-V-LP, ER/V and ER/VH designs.

Pressure valve in basic design

ER/V-F

Additional special devices available upon request

Table 1: Dimensions

Dimensions in mm / inches

To select the nominal size (DN), use the flow capacity chart on the following page

DN	200 / 8"	250 / 10"	300 / 12"	350 / 14"	400 / 16"	450 / 18"	500 / 20"	600 / 24"	700 / 28"
a	465 / 18.31	550 / 21.65	650 / 25.59	650 / 25.59	800 / 31.50	800 / 31.50	1000 / 39.37	1000 / 39.37	1200 / 47.24
b	860 / 33.86 (≤370 mbar ≤148 inchW.C.)	860 / 33.86 (≤240 mbar ≤96 inchW.C.)	1170 / 46.06 (≤240 mbar ≤96 inchW.C.)	1170 / 46.06 (≤270 mbar ≤108 inchW.C.)	1150 / 45.28 (≤220 mbar ≤88 inchW.C.)	1175 / 46.26 (≤170 mbar ≤68 inchW.C.)	1430 / 56.30 (≤130 mbar ≤52 inchW.C.)	1425 / 56.10 (≤140 mbar ≤56 inchW.C.)	1690 / 66.54 (≤140 mbar ≤56 inchW.C.)
b	980 / 38.58 (>370 mbar >148 inchW.C.)	980 / 38.58 (>240 mbar >96 inchW.C.)	1490 / 58.66 (>240 mbar >96 inchW.C.)	1490 / 58.66 (>270 mbar >108 inchW.C.)	1490 / 58.66 (>220 mbar ≤88 inchW.C.)	1515 / 59.65 (>170 mbar >68 inchW.C.)	1660 / 65.35 (>130 mbar >52 inchW.C.)	1655 / 65.16 (>140 mbar >56 inchW.C.)	1910 / 75.20 (>140 mbar >56 inchW.C.)

Table 2: Material selection

Design	A	B
Housing	Steel	Stainless Steel
Valve seat	Stainless Steel	Stainless Steel
Valve pallet	Stainless Steel or Steel-Stainless Steel	Stainless Steel
Sealing	FPM	FPM
Pressure spring	Stainless Steel	Stainless Steel
Weather hood	Steel	Stainless Steel

Special materials upon request

Table 3: Flange connection type

EN 1092-1, Form B1 or DIN 2501, Form C, PN 10	EN or DIN
ANSI 150 lbs RFSF	ANSI
other types upon request	

Flow Capacity Chart

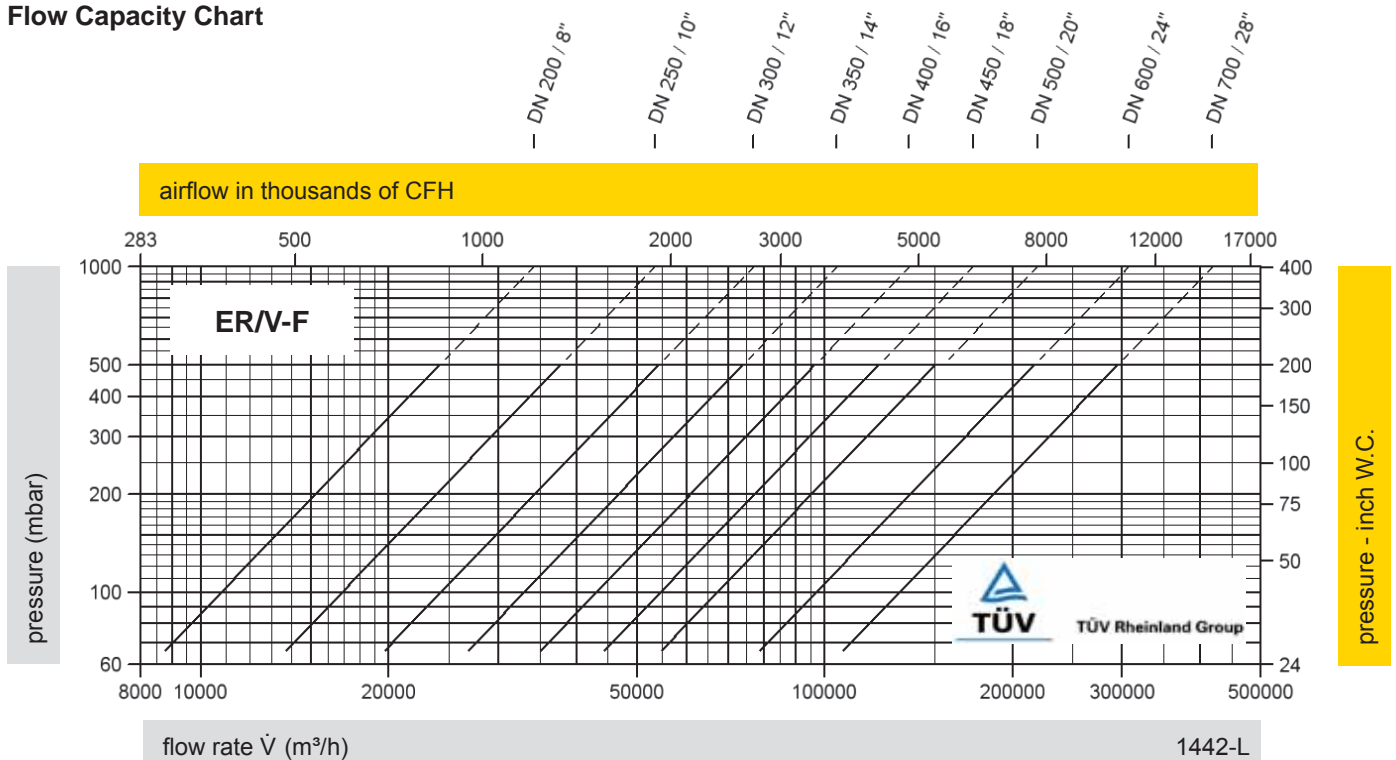

The flow capacity chart has been determined with a calibrated and TÜV certified flow capacity test rig. Volume flow \dot{V} in (m³/h) and CFH refer to the standard reference conditions of air ISO 6358 (20°C, 1bar). Conversion to other densities and temperatures refer to Vol. 1: "Technical Fundamentals".





Pressure Relief Valve made of plastic

PROTEGO® D/KSM

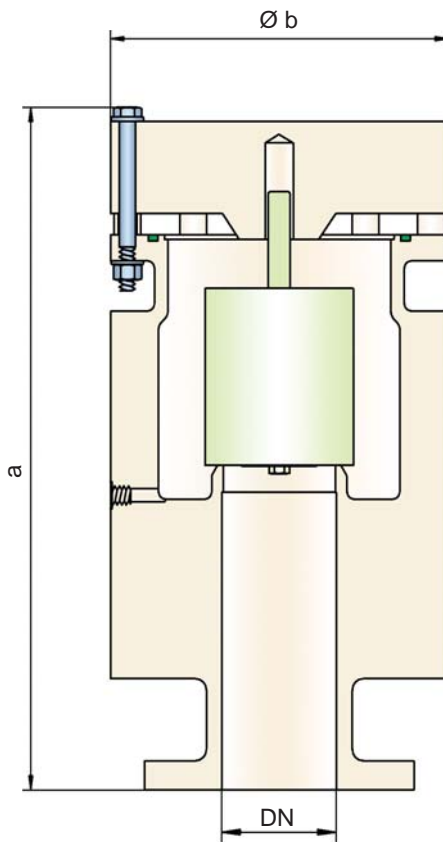

Pressure settings:

+6.0 mbar	up to +100 mbar (DN 50/2")
+2.4 inch W.C.	up to +40 inch W.C.
+4.0 mbar	up to +100 mbar (DN 80/3")
+1.6 inch W.C.	up to +40 inch W.C.
+4.5 mbar	up to +100 mbar (DN 100/4" - DN 200/8")
+1.8 inch W.C.	up to +40 inch W.C.

Higher pressure settings upon request.

Function and Description

The PROTEGO® valve D/KSM is a state-of-the-art pressure relief valve with excellent flow performance made out of high grade synthetic material. It is primarily used as a safety fitting for relieving pressure in tanks, containers, and process engineering equipment. The valve prevents emission losses almost up to the set pressure. The valve is a perfect solution for corrosive, polymerizing or sticky media.

The device will start to open as soon as the set pressure is reached and only requires 10% overpressure to full lift. Con-

tinuous investments into research and development have allowed PROTEGO® to develop a low pressure valve which has the same opening characteristic as a high pressure safety relief valve. This "full lift type" technology allows the valve to be set just 10% below the maximum allowable working pressure (MAWP) of the tank and still safely vent the required mass flow.

Due to our highly developed manufacturing technology, the tank pressure is maintained up to the set pressure, with a tightness that is far superior to the conventional standard. This feature is facilitated by special valve seats made of high quality synthetic material or PTFE. After the excess pressure is discharged, the valve reseats and provides a tight seal.

The optimized fluid dynamic design of the valve body and valve pallet is a result of many years of research work, which allow a stable operation of the valve pallet and optimized performance resulting in reduction of product losses.

Special Features and Advantages

- "full lift type" technology valve utilizes only 10% overpressure to reach full lift
- extreme tightness and hence least possible product losses and reduced environmental pollution
- the set pressure is close to the opening pressure which results in best possible pressure management of the system
- the valve pallet is guided within the housing to protect against harsh weather conditions
- corrosion resistant valve
- perfect solution for corrosive, polymerizing and sticky media
- weight reduction in comparison to steel/stainless steel
- smooth surface
- condensate drain
- different plastics can be combined
- maintenance friendly design

Design Types and Specifications

The valve pallet is weight-loaded, and the highest pressure levels are only attained with metal disks.

Pressure valve in basic design

D/KSM-

Additional special devices available upon request

Table 1: Dimensions

Dimensions in mm / inches

To select the nominal size (DN) use the flow capacity charts on the following pages

DN	50 / 2"	80 / 3"	100 / 4"	150 / 6"	200 / 8"
a	376 / 14.80	521 / 20.51	563 / 22.17 (543 / 21.38)*	687 / 27.05 (681 / 26.81)*	952 / 37.48
b	180 / 7.09	250 / 9.84	300 / 11.81	350 / 13.78 (405 / 15.94)*	560 / 22.05 (500 / 19.68)*

* Dimensions in brackets only for PVDF

Tabelle 2: Material selection for housing

Design	A	B	C
Housing	PE	PP	PVDF
Valve seats	PE	PP	PVDF
Sealing	FPM	FPM	FPM
Valve pallet	A, C, D	B, C, D	C, D

Special materials upon request

Table 3: Material selection for pressure valve pallet

Design	A	B	C	D
Pressure range (mbar) (inch W.C.)	+6.0 up to +16 +2.4 up to +6.4	+5.5 up to +16 +2.2 up to +6.4	+9.5 up to +30 +3.8 up to +12	+30 up to +100 +12 up to +40
Valve pallet	PE	PP	PVDF	Hastelloy
Sealing	PTFE	PTFE	PTFE	PTFE
Spindle guide	PE	PP	PVDF	Hastelloy
Weights	PE	PP	PVDF	Hastelloy

Special materials and other pressure settings are available upon request

Table 4: Flange connection type

EN 1092-1, Form A or DIN 2501, Form B, PN 16; from DN 200 PN 10	EN or DIN
ANSI 150 lbs FFSF	ANSI

other types upon request

Flow Capacity Chart

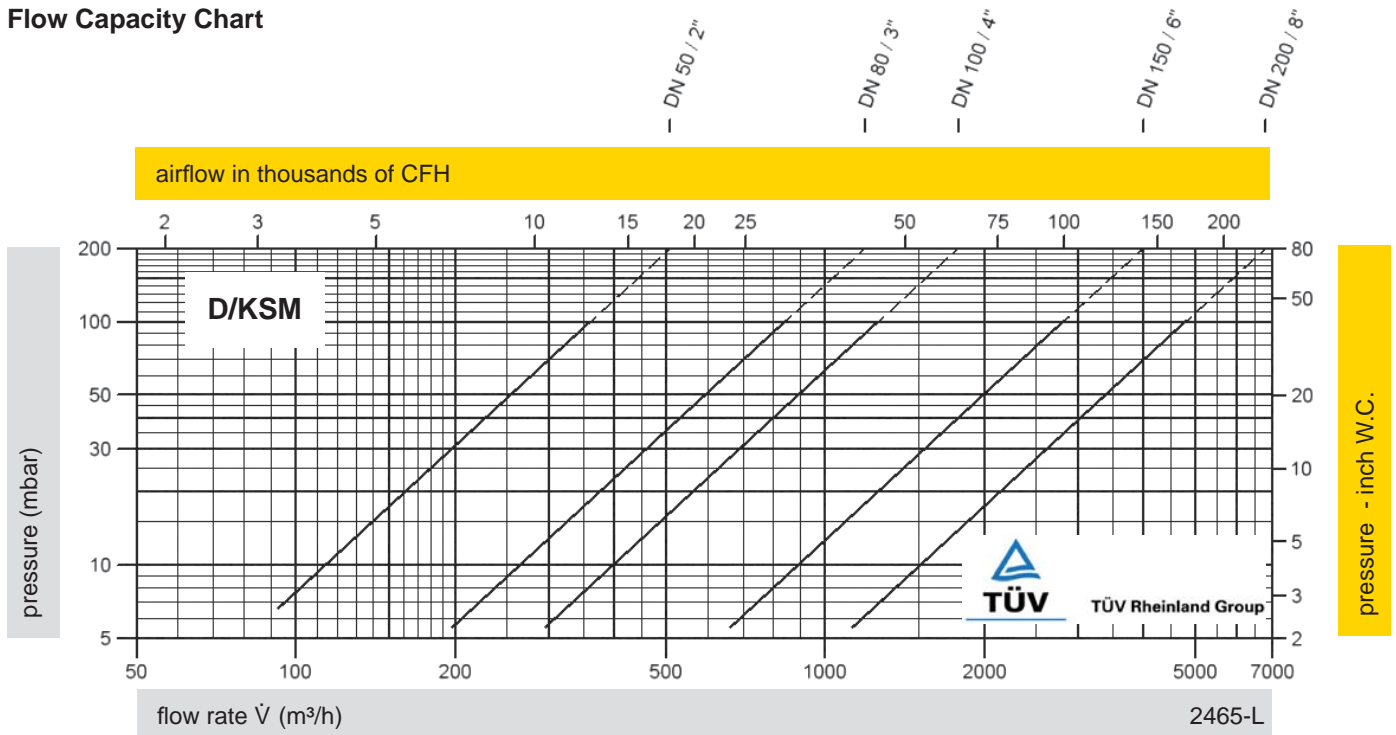

The flow capacity chart has been determined with a calibrated and TÜV certified flow capacity test rig. Volume flow \dot{V} in (m³/h) and CFH refer to the standard reference conditions of air ISO 6358 (20°C, 1bar). Conversion to other densities and temperatures refer to Vol. 1: "Technical Fundamentals".





Vacuum Relief Valve

PROTEGO® SV/E-1-0

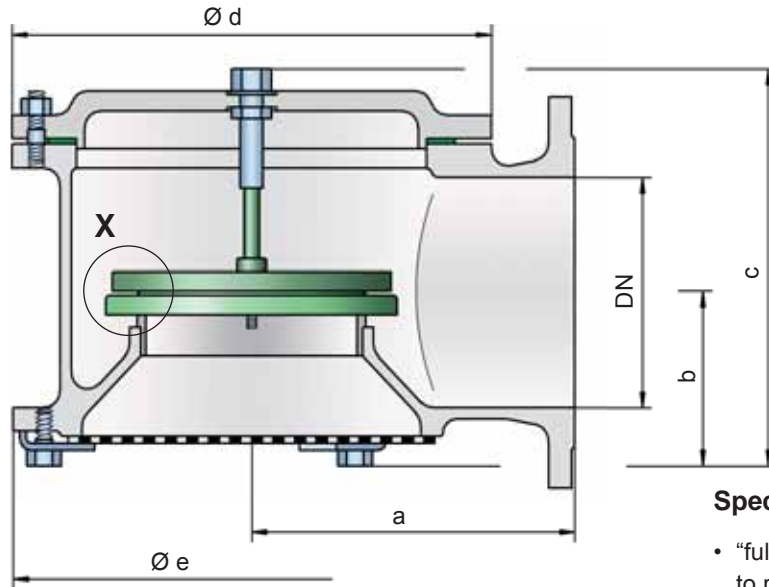

just 10% below the maximum allowable working pressure of the tank and still safely vent the required mass flow.

Due to our highly developed manufacturing technology the tank pressure is maintained up to set pressure, with a tightness that is far superior to the conventional standard. This feature is achieved by valve seats made of high quality stainless steel and with precisely lapped valve pallets (1) or with an air cushion seal (2) in conjunction with high quality FEP diaphragm. The valve pallets are also available with a PTFE seal to prevent the valve pallets from sticking when sticky products are used, and they enable the use of corrosive media. After the vacuum is relieved, the valve reseats and provides a tight seal again.

Special Features and Advantages

- “full lift type” technology valve utilizes only 10% overpressure to reach full lift
- extreme tightness and hence least possible product losses and reduced environmental pollution
- the set pressure is close to the opening pressure which results in best possible pressure management of the system
- high flow capacity
- the valve pallet is guided within the housing to protect against harsh weather conditions
- can be used in areas subject to an explosion hazard
- self-actuated condensate drain
- best technology for API-tanks

Detail X

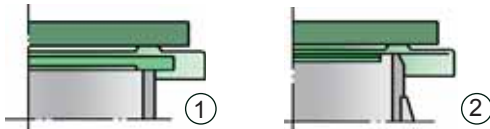

Vacuum settings:

-2.0 mbar up to -60 mbar
 -0.8 inch W.C. up to -24 inch W.C.
 Higher vacuum settings upon request.

Function and Description

The SV/E-1-0 type PROTEGO® valve is a highly developed vacuum relief valve with excellent flow performance. It is primarily used as a safety device for relieving vacuum in tanks, containers and process engineering equipment. The valve offers reliable protection against vacuum, and prevents inbreathing of air close to the set pressure.

The device will start to open as soon as the set pressure is reached and only requires 10% overpressure to full lift. Continuous investments into research and development have allowed PROTEGO® to develop a low pressure valve which has the same opening characteristic as a high pressure safety relief valve. This “full lift type” technology allows the valve to be set

Design Types and Specifications

The valve pallet is weight-loaded. Higher vacuum can be achieved upon request with a special spring-loaded design.

There are two different designs:

Vacuum valve in basic design

SV/E-1-0 -

Vacuum valve with heating jacket

SV/E-1-0 -

Additional special devices available upon request.

Table 1: Dimensions

Dimensions in mm / inches

To select the nominal size (DN) use the flow capacity chart on the following page

DN	50 / 2"	80 / 3"	100 / 4"	150 / 6"	200 / 8"	250 / 10"	300 / 12"
a	140 / 5.51	170 / 6.69	190 / 7.48	230 / 9.06	300 / 11.81	325 / 12.80	425 / 16.73
b	75 / 2.95	85 / 3.35	95 / 3.74	120 / 4.72	140 / 5.51	165 / 6.50	205 / 8.07
c	205 / 8.07	205 / 8.07	285 / 11.22	360 / 14.17	405 / 15.94	460 / 18.11	500 / 19.69
d	170 / 6.69	235 / 9.25	280 / 11.02	335 / 13.19	445 / 17.52	505 / 19.88	505 / 19.88
e	215 / 8.46	215 / 8.46	255 / 10.04	335 / 13.19	425 / 16.73	460 / 18.11	625 / 24.61

Dimensions for vacuum relief valve with heating jacket upon request

Table 2: Material selection for housing

Design	B	C	D	
Housing Heating jacket (SV/E-1-0-H-...)	Steel Steel	Stainless Steel Stainless Steel	Aluminium –	The housings is also available with an ECTFE-Coating
Valve seat	Stainless Steel	Stainless Steel	Stainless Steel	Special materials upon request
Sealing	PTFE	PTFE	PTFE	

Table 3: Material selection for vacuum valve pallet

Design	A	B	C	D	E	F
vacuum range (mbar) (inch W.C.)	-2.0 up to -3.5 -0.8 up to -1.4	<-3.5 up to -14 <-1.4 up to 5.6	<-14 up to -35 <-5.6 up to -14	<-35 up to -60 <-14 up to -24	<-14 up to -35 <-5.6 up to -14	<-35 up to -60 <-14 up to -24
Valve pallet	Aluminium	Stainless Steel	Stainless Steel	Stainless Steel	Stainless Steel	Stainless Steel
Sealing	FEP	FEP	Metal to Metal	Metal to Metal	PTFE	PTFE

Special materials (Alu-coated, Titanium, Hastelloy) and higher vacuum settings are available upon request

Table 4: Flange connection type

EN 1092-1, Form B1 or DIN 2501, Form C, PN 16; from DN 200 PN 10	EN or DIN	other types upon request
ANSI 150 lbs RFSF	ANSI	

Flow Capacity Chart

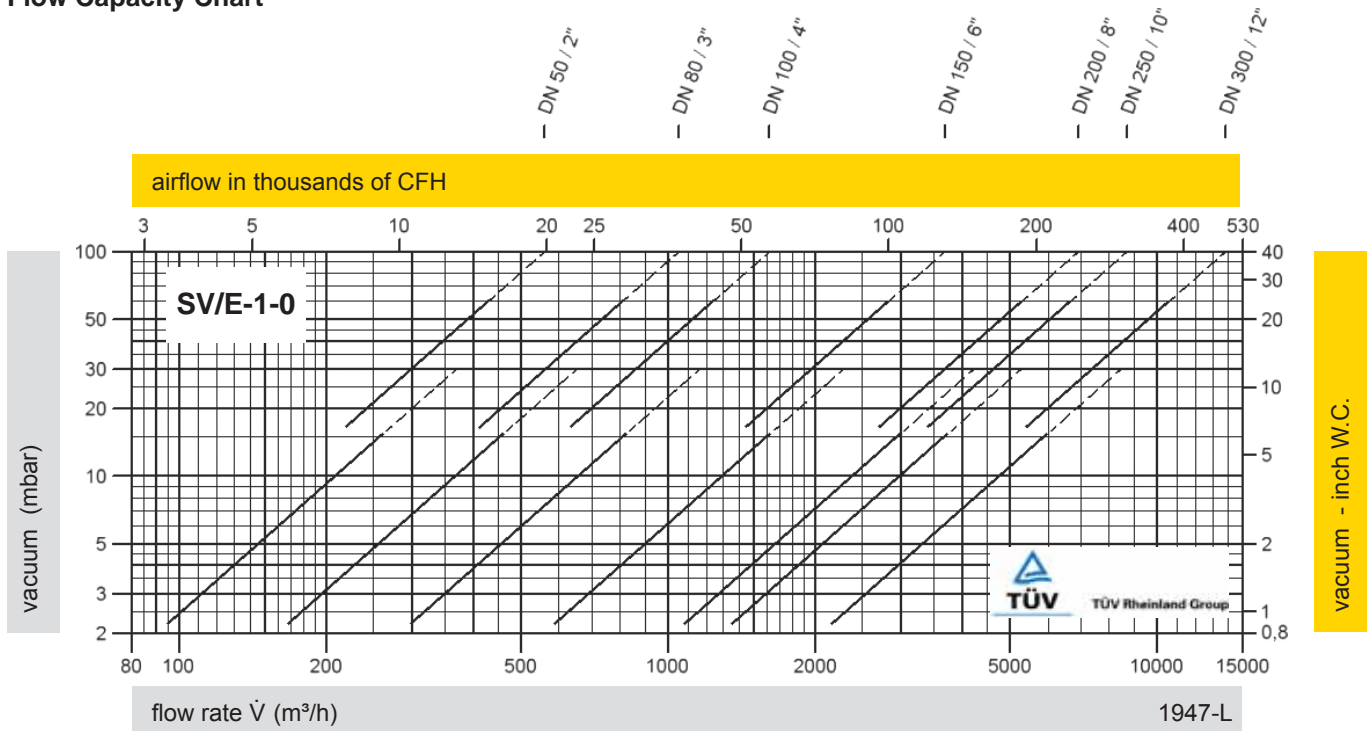

The flow capacity chart has been determined with a calibrated and TÜV certified flow capacity test rig. Volume flow \dot{V} in (m³/h) and CFH refer to the standard reference conditions of air ISO 6358 (20°C, 1bar). Conversion to other densities and temperatures refer to Vol. 1: "Technical Fundamentals".



for safety and environment



Vacuum Relief Valve in a special heat jacketed design

PROTEGO® SV/T-0-H

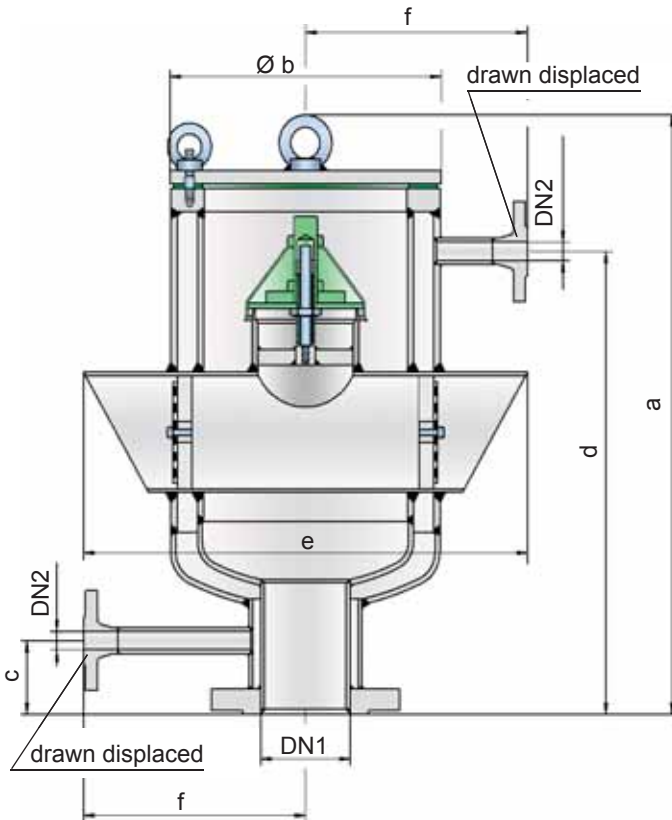

Vacuum settings:

-7 mbar up to -50 mbar
-2.8 inch W.C. up to -20 inch W.C.
Higher and lower vacuum settings upon request.

Function and Description

The SV/T-0-H type PROTEGO® valve is a highly developed vacuum relief valve with a valve housing that comes with a heating jacket down to the flange. It is primarily used as a safety device for inbreathing to tanks, containers, and process engineering equipment under difficult operating conditions. This includes extreme weather conditions or products that tend to form polymers at certain temperatures, adhere, or form deposits that negatively influence function (such as bitumen, tar, dust). The valve offers reliable protection against vacuum and prevents the intake of air close to the set vacuum.

When the set vacuum is reached, the valve starts to open and reaches full lift within a 40% vacuum increase. Up to the set vacuum, the tank vacuum is maintained with a seal that is far superior to the conventional standard due to the highly developed manufacturing technology. This feature is achieved by valve seats made of high quality stainless steel with precisely lapped valve pallets and a reinforced housing design. After the vacuum is relieved, the valve reseats and again provides a tight seal.

Special Features and Advantages

- excellent tightness and hence least possible product losses and reduced environmental pollution
- high flow capacity
- the valve pallet is guided within the housing to protect against harsh weather conditions
- can be used in areas subject to an explosion hazard
- complete heat jacketed design down to the flange to avoid cold bridges
- maximum permissible heating medium temperature of 320°C / 608°F (at 6 bar / 87 psi)
- a special design that preheats incoming air is also available
- a special design with a heatable valve cover is also available
- the valve pallet cover prevents the set pressure from being distorted by dust or condensate
- reinforced housing design
- a special design with a mechanical vent pallet lift device is available

Design Types and Specifications

The valve pallet is weight-loaded.

Vacuum valve in basic design with heating jacket

SV/T - 0 - H

Additional special devices available upon request.

Table 1: Dimensions

Dimensions in mm / inches

To select the nominal size (DN) use the capacity chart on the following page

DN1	80 / 3" *	100 / 4"	150 / 6"	200 / 8"	250 / 10"
DN2	15 / ½"	15 / ½"	15 / ½"	15 / ½"	15 / ½"
a	570 / 22.44	570 / 22.44	720 / 28.35	920 / 36.22	1050 / 41.34
b	275 / 10.83	275 / 10.83	355 / 13.98	405 / 15.94	508 / 20.00
c	70 / 2.76	70 / 2.76	60 / 2.36	70 / 2.76	70 / 2.76
d	440 / 17.32	440 / 17.32	590 / 23.23	790 / 31.10	920 / 36.22
e	450 / 17.72	450 / 17.72	650 / 25.59	750 / 29.53	950 / 37.40
f	225 / 8.86	225 / 8.86	260 / 10.24	300 / 11.91	350 / 13.78

* also available with special flange DN 50 / 2"

Table 2: Material selection for housing

Design	A	B	Special materials upon request
Housing	Steel	Stainless Steel	
Heating jacket	Steel	Stainless Steel	
Valve seat	Stainless Steel	Stainless Steel	
Sealing	PTFE	PTFE	

Table 3: Material selection for vacuum valve pallet

Design	A	B	C	Special materials and other vacuum settings are available upon request
Vacuum range (mbar) (inch W.C.)	-7.0 up to -25 -2.8 up to -10	-10 up to -30 -4.0 up to -12	-30 up to -50 -12 up to -20	
Valve pallet	Aluminium	Stainless Steel	Stainless Steel	
Valve pallet hood	Stainless Steel	Stainless Steel	Stainless Steel	
Sealing	Metal to Metal	Metal to Metal	Metal to Metal	

Table 4: Flange connection type

EN 1092-1, Form B1 or DIN 2501, Form C, PN 16; from DN 200 PN 10	EN or DIN	other types upon request
ANSI 150 lbs RFSF	ANSI	



for safety and environment

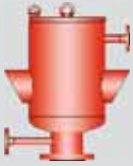

Vacuum Relief Valve

Flow Capacity Chart

PROTEGO® SV/T-0-H

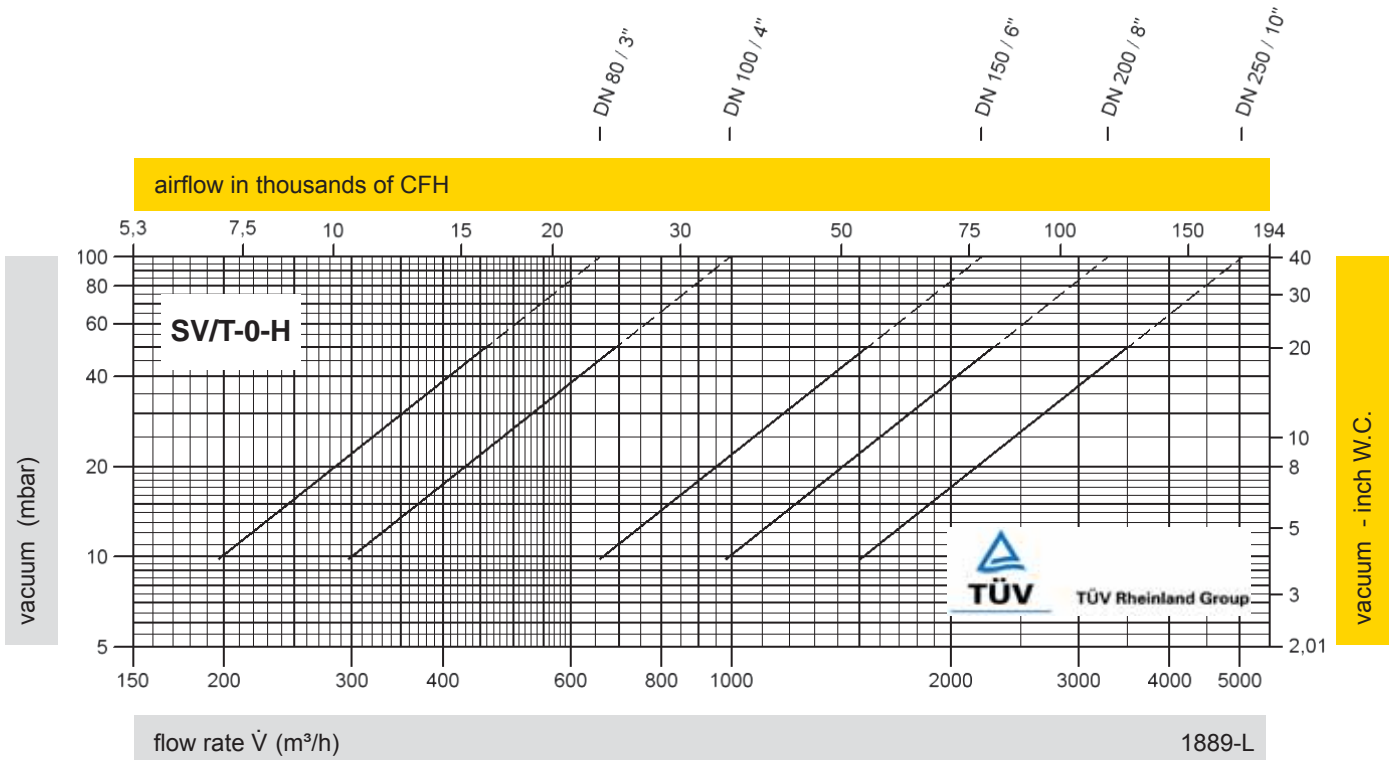

Remark

$$\text{set pressure} = \frac{\text{opening pressure resp. tank design pressure}}{1.4}$$

Set pressure = the valve starts to open

Opening pressure = set pressure plus overpressure

Overpressure = pressure increase over the set pressure

The flow capacity chart has been determined with a calibrated and TÜV certified flow capacity test rig. Volume flow \dot{V} in (m³/h) and CFH refer to the standard reference conditions of air ISO 6358 (20°C, 1bar). Conversion to other densities and temperatures refer to Vol. 1: "Technical Fundamentals".

Notes:

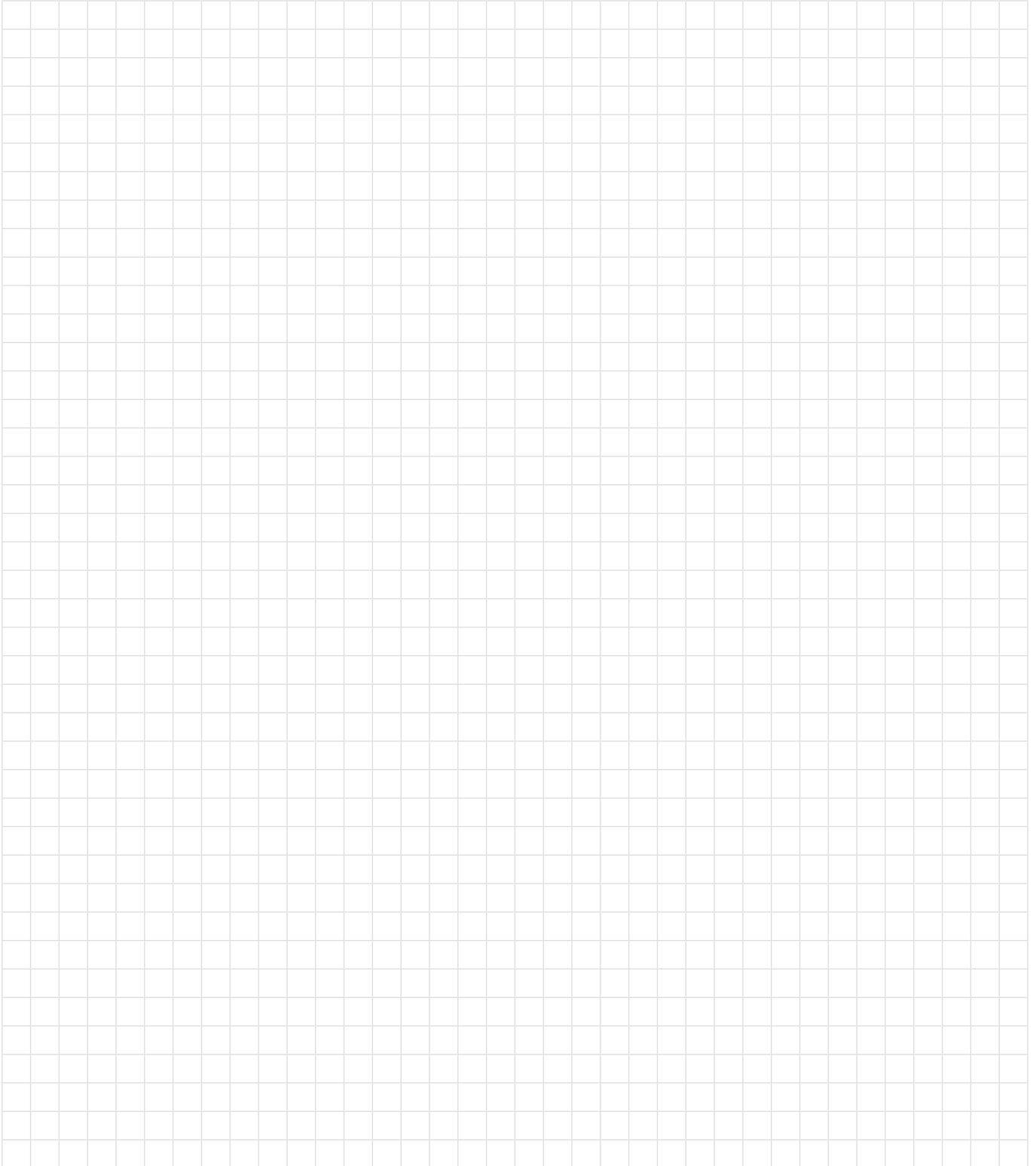

for safety and environment

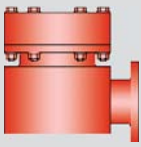

Vacuum Relief Valve

made of plastic

PROTEGO® V/KSM

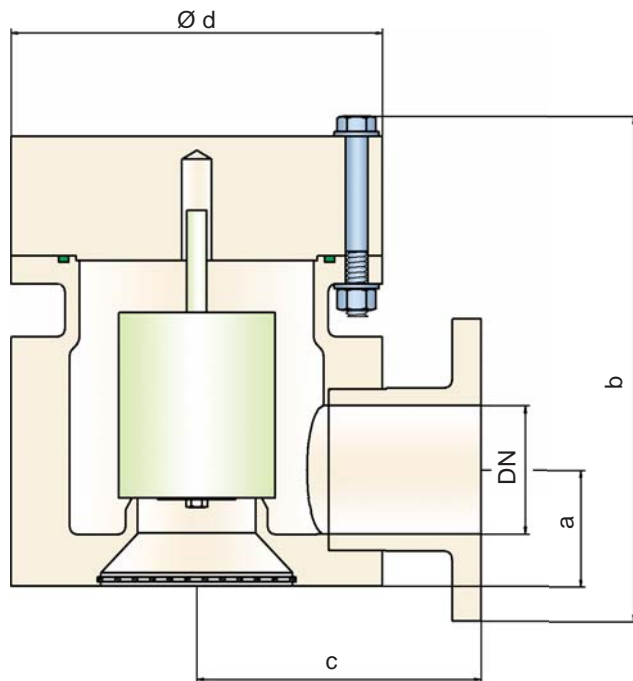

Vacuum settings:

-6.0 mbar	up to -100 mbar (DN 50/2")
-2.4 inch W.C.	up to -40 inch W.C.
-4.0 mbar	up to -100 mbar (DN 80/3")
-1.6 inch W.C.	up to -40 inch W.C.
-4.5 mbar	up to -100 mbar (DN 100/4" - DN 200/8")
-1.8 inch W.C.	up to -40 inch W.C.

Higher pressure settings upon request.

Function and Description

The PROTEGO® valve V/KSM is a state-of-the-art vacuum relief valve with excellent flow performance made of highgrade synthetic material. It is used as a safety device to relieve vacuum in tanks, containers, and process engineering equipment; it prevents the inbreathing of air until reaching the set vacuum. The valve is a perfect solution for corrosive, polymerizing or sticky media.

The device will start to open as soon as the set vacuum is reached and is fully open within 10% vacuum increase. Continuous investments into research and development have

allowed PROTEGO® to develop a low pressure valve which has the same opening characteristic as a high pressure safety relief valve. This "full lift type" technology allows the valve to be set just 10% below the maximum allowable working vacuum (MAWV) of the tank and still safely vent the required mass flow.

Due to our highly developed manufacturing technology, the tank pressure is maintained up to the set vacuum, with a seal that is far superior to the conventional standard. This feature is achieved by valve seats made of high-performance plastics and a high grade PTFE seal. After the vacuum is compensated, the valve reseats and provides a tight seal.

The optimized fluid dynamic design of the valve body and valve pallet is a result of many years of research work, which allow a stable operation of the valve pallet and optimized performance resulting in reduction of product losses.

Special Features and Advantages

- "full lift type" technology valve utilizes only 10% overpressure to reach full lift
- extreme tightness and hence least possible product losses and reduced environmental pollution
- the set pressure is close to the opening pressure which results in best possible pressure management of the system
- the valve pallet is guided within the housing to protect against harsh weather conditions
- corrosion resistant valve
- perfect solution for corrosive, polymerizing and sticky media
- weight reduction in comparison to steel/stainless steel
- smooth surface
- automatic condensate drain
- different plastics can be combined
- maintenance friendly design

Design Types and Specifications

The valve pallet is weight-loaded, and the highest pressure levels are only attained with metal discs.

Vacuum valve in basic design

V/KSM-

Additional special devices available upon request.

Table 1: Dimensions

Dimensions in mm / inches

To select the nominal size (DN), use the flow capacity chart on the following page

DN	50 / 2"	80 / 3"	100 / 4"	150 / 6"	200 / 8"
a	57 / 2.24	77 / 3.03	87 / 3.43 (115 / 4.53)*	126 / 4.96 (146 / 5.75)*	180 / 7.09 (175 / 6.89)*
b	259 / 10.20	376 / 14.80	373 / 14.69 (338 / 13.31)*	460 / 18.11 (427 / 16.81)*	469 / 18.46 (437 / 17.20)*
c	150 / 5.91	200 / 7.87	225 / 8.86	280 / 11.02	350 / 13.78
d	180 / 7.09	250 / 9.84	300 / 11.81	350 / 13.78 (405 / 15.94)*	560 / 22.05 (500 / 19.68)*

* Dimensions in brackets only for PVDF

Table 2: Material selection for housing

Design	A	B	C
Housing	PE	PP	PVDF
Valve seat	PE	PP	PVDF
Sealing	FPM	FPM	FPM
Valve pallet	A, C, D	B, C, D	C, D

Special Materials upon request

Table 3: Material selection for vacuum valve pallet

Design	A	B	C	D
Vacuum range (mbar) (inch W.C.)	-6.0 up to -16 -2.4 up to -6.4	-5.5 up to -16 -2.2 up to -6.4	-9.5 up to -30 -3.8 up to -12	-30 up to -100 -12 up to -40
Valve pallet	PE	PP	PVDF	Hastelloy
Sealing	PTFE	PTFE	PTFE	PTFE
Spindle guide	PE	PP	PVDF	Hastelloy
Weight	PE	PP	PVDF	Hastelloy

Special materials and other vacuum settings are available upon request

Table 4: Flange connection type

EN 1092-1, Form A or DIN 2501, Form B, PN 16; from DN 200 PN 10	EN or DIN
ANSI 150 lbs FFSS	ANSI

other types upon request

Flow Capacity Chart

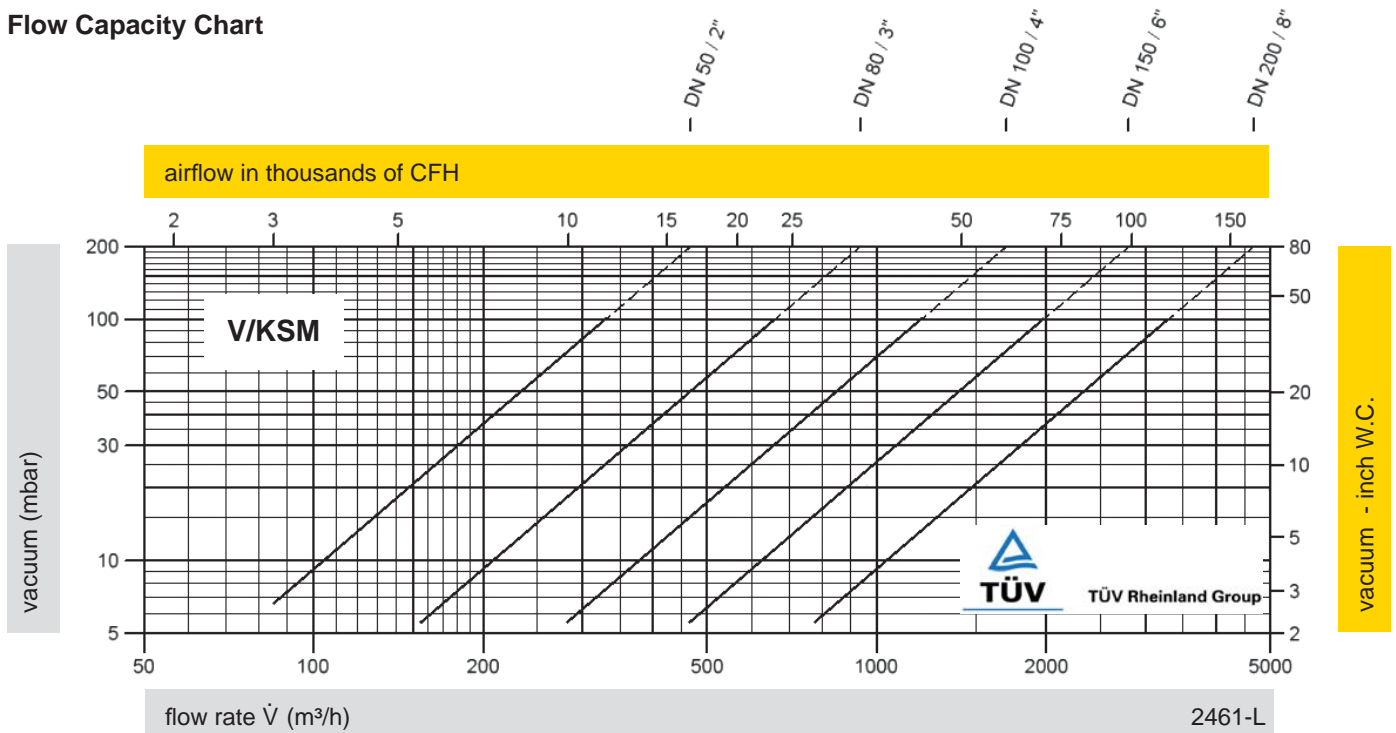

The flow capacity chart has been determined with a calibrated and TÜV certified flow capacity test rig. Volume flow \dot{V} in (m³/h) and CFH refer to the standard reference conditions of air ISO 6358 (20°C, 1bar). Conversion to other densities and temperatures refer to Vol. 1: "Technical Fundamentals".



for safety and environment



Pressure and Vacuum Relief Valve

PROTEGO® PV/EL

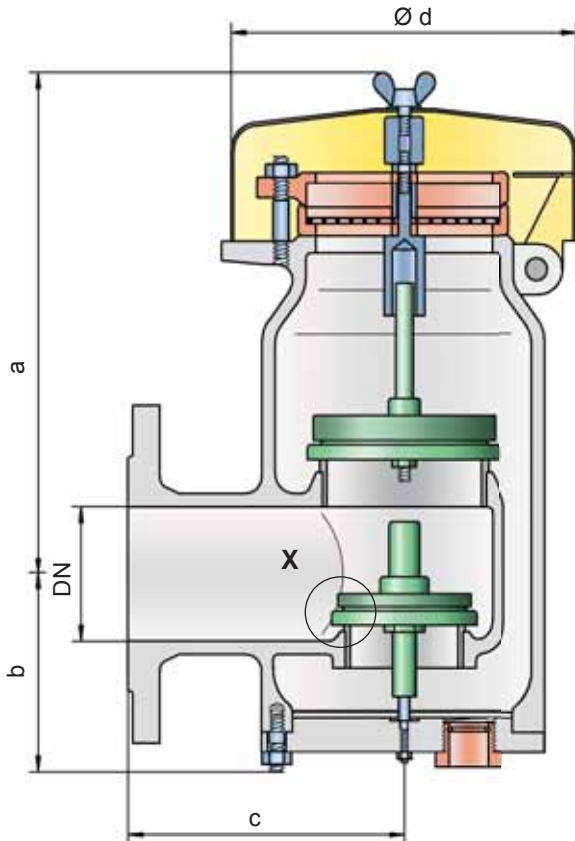

Detail X

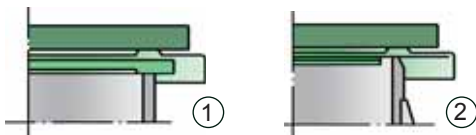

Settings:

Pressure: +2.0 mbar up to +210 mbar
 +0.8 inch W.C. up to +84 inch W.C.

Vacuum: -14 mbar up to -35 mbar
 -5.6 inch W.C. up to -14 inch W.C.

vacuum: -3.5 mbar up to -14 mbar
 -1.4 inch W.C. up to -5.6 inch W.C.

for pressure up to max. + 150 mbar / 60.2 inch W.C.

Higher and lower settings upon request.

Function and Description

The PV/EL type PROTEGO® valve is a highly developed combined pressure and vacuum relief valve. It is primarily used as a safety device for relieving pressure and vacuum in tanks, containers and process engineering equipment. The valve offers reliable protection against overpressure and excessive vacuum. It prevents also the impermissible loss of product vapors close to the set pressure as well as the intake of air on the vacuum side close to set vacuum.

The device will start to open as soon as the set pressure is reached and only requires 10% overpressure to full lift. Continuous investments into research and development have

allowed PROTEGO® to develop a low pressure valve which has the same opening characteristic as a high pressure safety relief valve. This "full lift type" technology allows the valve to be set just 10% below the maximum allowable working pressure or vacuum (MAWP or MAWV) of the tank and still safely vent the required mass flow. The opening characteristic is the same for pressure and vacuum relief.

Due to the highly developed manufacturing technology, the tank pressure is maintained up to the set pressure, with a tightness that is far superior to the conventional standard. This feature is achieved by valve seats made of high quality stainless steel and with precisely lapped valve pallets (1) or with an air cushion seal (2) in conjunction with high quality FEP diaphragm. The valve pallets are also available with a PTFE seal to prevent the valve pallet from sticking when sticky products are used, and they enable the use of corrosive media. After the excess pressure is discharged or the vacuum is compensated, the valve reseats and provides a tight seal.

The optimized fluid dynamic design of the valve body and valve pallet is a result of many years of research work, which allow a stable operation of the valve pallet and optimized performance resulting in reduction of product losses.

Special Features and Advantages

- "full lift type" technology valve utilizes only 10% overpressure to reach full lift
- extreme tightness and hence least possible product losses and reduced environmental pollution
- the set pressure is close to the opening pressure which results in best possible pressure management of the system
- high flow capacity
- the valve pallet is guided within the housing to protect against freezing in cold weather
- can be used in areas subject to an explosion hazard
- self-actuated condensate drain
- special design with lifting gear can be purchased

Design Types and Specifications

The valve pallets are weight-loaded. At set pressures greater than 60 mbar (24.1 inch W.C.), an elongated construction is used.

There are two different designs

Pressure/vacuum relief valve in basic design **PV/EL - □**

Pressure/vacuum relief valve with heating jacket **PV/EL - □^H**

Additional special devices available upon request.

Any combination of vacuum and pressure levels can be set for the valve. When the difference between the pressure and vacuum exceeds 150 mbar / 60.2 inch W.C., special valve pallets are used.

Table 1: Dimensions

Dimensions in mm / inches

To select the nominal size (DN), please use the flow capacity charts on the following pages

DN	50 / 2"	50 / 2"	80 / 3"	80 / 3"
Set pressure	≤ +60 mbar ≤ +24.1 inch W.C.	> +60 mbar > +24.1 inch W.C.	≤ +60 mbar ≤ +24.1 inch W.C.	> +60 mbar > +24.1 inch W.C.
a	308 / 12.13	443 / 17.44	308 / 12.13	443 / 17.44
b	108 / 4.25	108 / 4.25	108 / 4.25	108 / 4.25
c	165 / 6.50	165 / 6.50	167 / 6.57	167 / 6.57
d	218 / 8.58	218 / 8.58	218 / 8.58	218 / 8.58

Dimensions for pressure/
vacuum relief valve with
heating jacket upon request**Table 2: Material selection for housing**

Design	B	C
Housing	Steel	Stainless Steel
Heating jacket (PV/EL-H-...)	Steel	Stainless Steel
Valve seat	Stainless Steel	Stainless Steel
Weather hood	Steel	Stainless Steel
Protective mesh screen	Stainless Steel	Stainless Steel

Special materials upon request

Table 3: Material selection for pressure valve pallet

Design	A	B	C	D
Pressure range (mbar) (inch W.C.)	+2.0 up to +3.5 +0.8 up to +1.4	>+3.5 up to +14 >+1.4 up to +5.6	>+14 up to +210 >+5.6 up to +84	>+14 up to +210 >+5.6 up to +84
Valve pallet	Aluminium	Stainless Steel	Stainless Steel	Stainless Steel
Sealing	FEP	FEP	Metal to Metal	PTFE

Special material as well as
higher set pressure upon
request**Table 4: Material selection for vacuum valve pallet**

Design	A	B	C	D
Vacuum range (mbar) (inch W.C.)	-3.5 up to -5.0 -1.4 up to -2.0	<-3.5 up to -14 <-2.0 up to -5.6	<-14 up to -35 <-5.6 up to -14	<-14 up to -35 <-5.6 up to -14
Valve pallet	Aluminium	Stainless Steel	Stainless Steel	Stainless Steel
Sealing	FEP	FEP	Metal to Metal	PTFE

Special material as well as
higher set vacuum upon
request**Table 5: Flange connection type**

EN 1092-1, Form B1 or DIN 2501, Form C, PN 16	EN or DIN
ANSI 150 lbs RFSF	ANSI

other types upon request



for safety and environment



Pressure and Vacuum Relief Valve

Flow Capacity Charts

PROTEGO® PV/EL

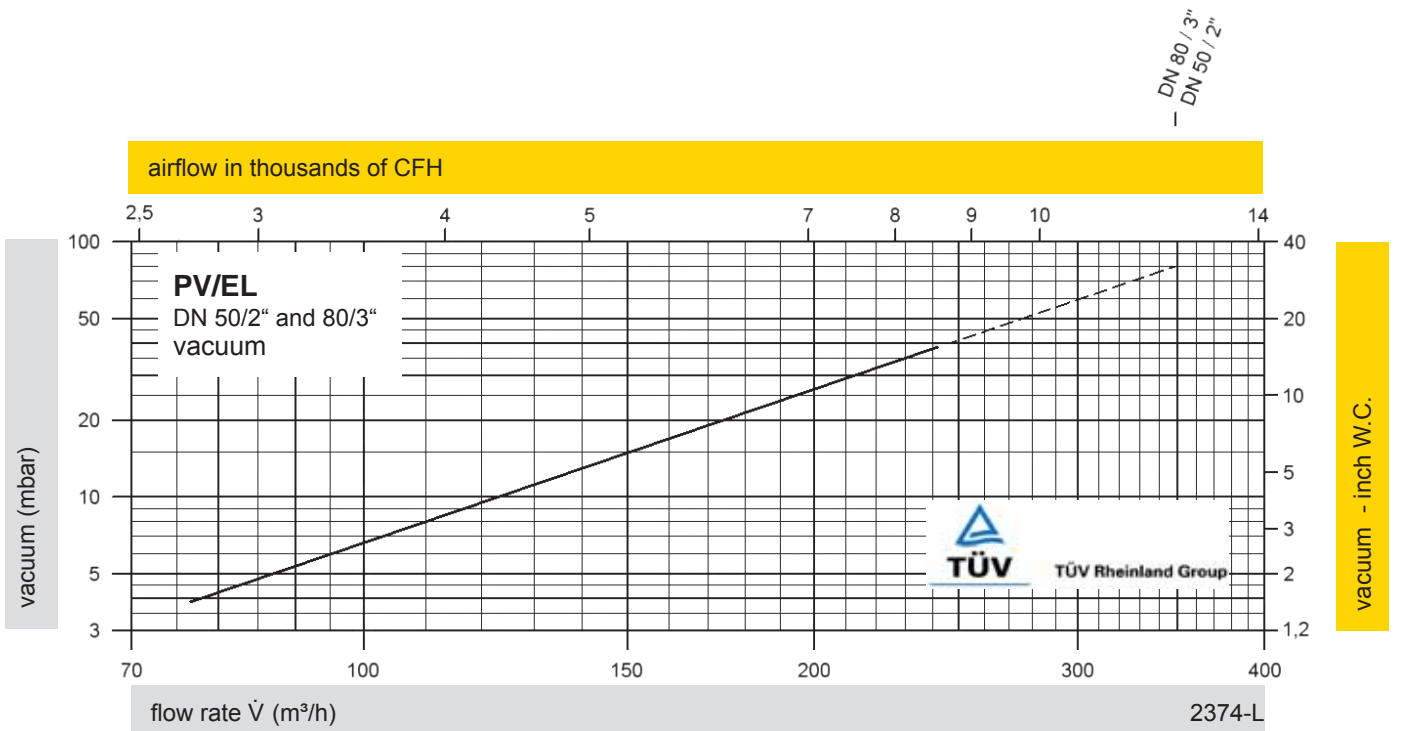
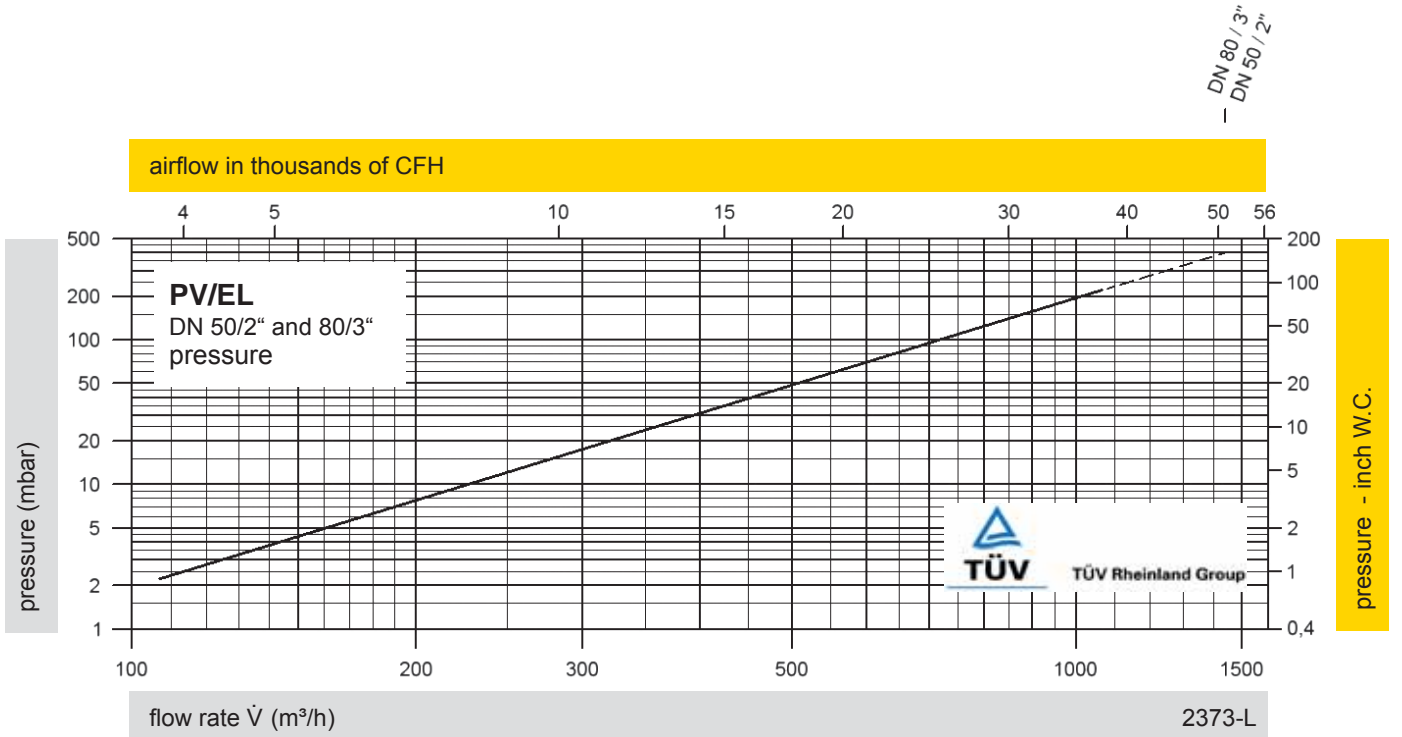

The flow capacity charts have been determined with a calibrated and TÜV certified flow capacity test rig. Volume flow \dot{V} in (m³/h) and CFH refer to the standard reference conditions of air ISO 6358 (20°C, 1bar). Conversion to other densities and temperatures refer to Vol. 1: "Technical Fundamentals".



Pressure and Vacuum Relief Valve

PROTEGO® PV/ELR

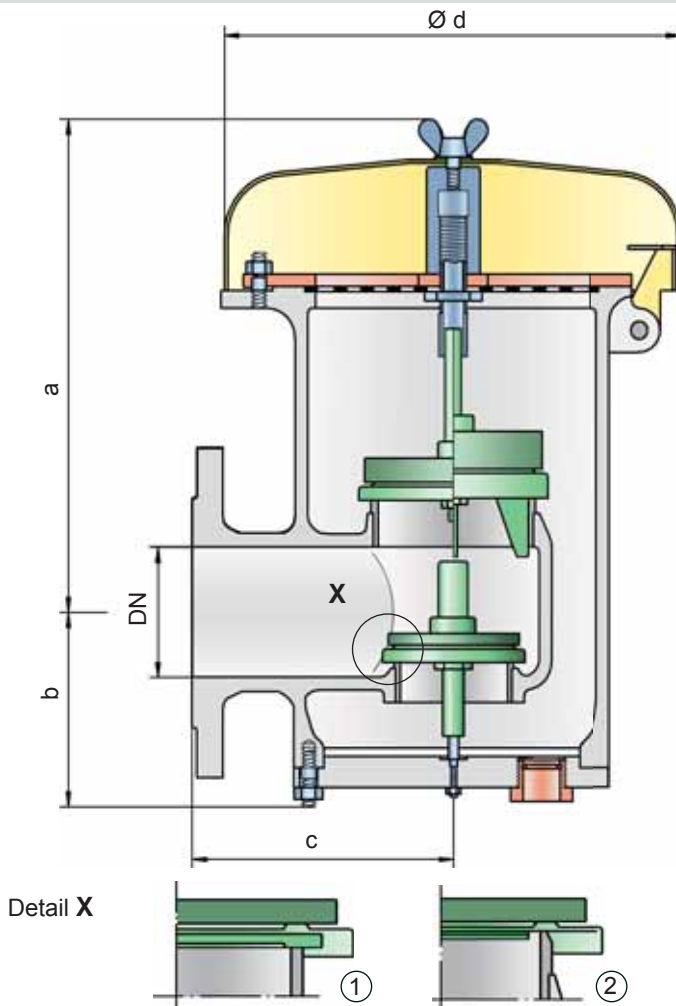

Settings:

Pressure:	+2.0 mbar	up to	+210 mbar
	+0.8 inch W.C.	up to	+84 inch W.C.
Vacuum:	-14 mbar	up to	-50 mbar
	-5.6 inch W.C.	up to	-20 inch W.C.
vacuum:	-3.5 mbar	up to	-14 mbar
	-1.4 inch W.C.	up to	-5.6 inch W.C.

for pressure up to max. + 150 mbar / 60.2 inch W.C.

Higher and lower settings upon request

Function and Description

The PV/ELR type PROTEGO® valve is a highly developed combined pressure and vacuum relief valve with excellent flow performance. Typically the valve is installed in the in- and outbreathing lines of tanks, vessels and process apparatus to protect against unallowable high and low pressure. The valve prevents emission losses almost up to the set pressure and prevents air intake almost up to set vacuum.

The device will start to open as soon as the set pressure is reached and only requires 10% overpressure to full lift. Continuous investments into research and development have allowed PROTEGO® to develop a low pressure valve which has the same opening characteristic as a high pressure safety relief valve. This "full lift type" technology allows the valve to be

set just 10% below the maximum allowable working pressure or vacuum (MAWP or MAWV) of the tank and still safely vent the required mass flow. The opening characteristic is the same for pressure and vacuum relief.

Due to the highly developed manufacturing technology, the tank pressure is maintained up to the set pressure, with a tightness that is far superior to the conventional standard. This feature is achieved by valve seats made of high quality stainless steel and with precisely lapped valve pallets (1) or with an air cushion seal (2) in conjunction with high quality FEP diaphragm. The valve pallets are also available with a PTFE seal to prevent the valve pallet from sticking when sticky products are used, and they enable the use of corrosive media. After the excess pressure is discharged or the vacuum is compensated, the valve reseats and provides a tight seal.

The optimized fluid dynamic design of the valve body and valve pallet is a result of many years of research work, which allow a stable operation of the valve pallet and optimized performance resulting in reduction of product losses.

Special Features and Advantages

- "full lift type" technology valve utilizes only 10% overpressure to reach full lift
- extreme tightness and hence least possible product losses and reduced environmental pollution
- the set pressure is close to the opening pressure which results in best possible pressure management of the system
- high flow capacity
- the valve pallet is guided within the housing to protect against freezing in cold weather
- can be installed in explosion hazardous areas
- self-actuated condensate drain
- compact design saves space
- special design with lifting gear can be purchased
- maintenance friendly design

Design Types and Specifications

The valve pallets are weight-loaded. At set pressures greater than 35 mbar (14 inch W.C.), an elongated construction is used.

There are two different designs:

Pressure/vacuum relief valve in basic design **PV/ELR -**

Pressure/vacuum relief valve with heating jacket **PV/ELR -**

Additional special devices available upon request.

Any combination of vacuum and pressure levels can be set for the valve. When the difference between the pressure and vacuum exceeds 150 mbar/60.2 inch W.C., special valve pallets are used.

Table 1: Dimensions

Dimensions in mm / inches

To select the nominal size (DN), please use the flow capacity charts on the following pages

DN	80 / 3"	80 / 3"	100 / 4"	100 / 4"	Dimensions for pressure/ vacuum relief valve with heating jacket upon request
Set pressure	≤ +35 mbar ≤ +14 inch W.C.	> +35 mbar > +14 inch W.C.	≤ +35 mbar ≤ +14 inch W.C.	> +35 mbar > +14 inch W.C.	
a	345 / 13.58	475 / 18.70	345 / 13.58	475 / 18.70	
b	146 / 5.75	146 / 5.75	146 / 5.75	146 / 5.75	
c	218 / 8.58	218 / 8.58	218 / 8.58	218 / 8.58	
d	353 / 13.90	353 / 13.90	353 / 13.90	353 / 13.90	

Table 2: Material selection for housing

Design	B	C	Special materials upon request
Housing	Steel	Stainless Steel	
Heating jacket (PV/ELR-H-...)	Steel	Stainless Steel	
Valve seat	Stainless Steel	Stainless Steel	
Weather hood	Steel	Stainless Steel	
Protective mesh screen	Stainless Steel	Stainless Steel	

Table 3: Material selection for pressure valve pallet

Design	A	B	C	D	Special material as well as higher set pressure upon request
Pressure range (mbar) (inch W.C.)	+2.0 up to +3.5 +0.8 up to +1.4	>+3.5 up to +14 >+1.4 up to +5.6	>+14 up to +210 >+5.6 up to +84	>+14 up to +210 >+5.6 up to +84	
Valve pallet	Aluminium	Stainless Steel	Stainless Steel	Stainless Steel	
Sealing	FEP	FEP	Metal to Metal	PTFE	

Table 4: Material selection for vacuum valve pallet

Design	A	B	C	D	Special material as well as higher set vacuum upon request
Vacuum range (mbar) (inch W.C.)	-3.5 up to -5.0 -1.4 up to -2.0	<-5.0 up to -14 <-2.0 up to -5.6	<-14 up to -50 <-5.6 up to -20	<-14 up to -50 <-5.6 up to -20	
Valve pallet	Aluminium	Stainless Steel	Stainless Steel	Stainless Steel	
Sealing	FEP	FEP	Metal to Metal	PTFE	

Table 5: Flange connection type

EN 1092-1, Form B1 or DIN 2501, Form C, PN 16	EN or DIN	other types upon request
ANSI 150 lbs RFSF	ANSI	



for safety and environment



Pressure and Vacuum Relief Valve
Flow Capacity Charts

PROTEGO® PV/ELR

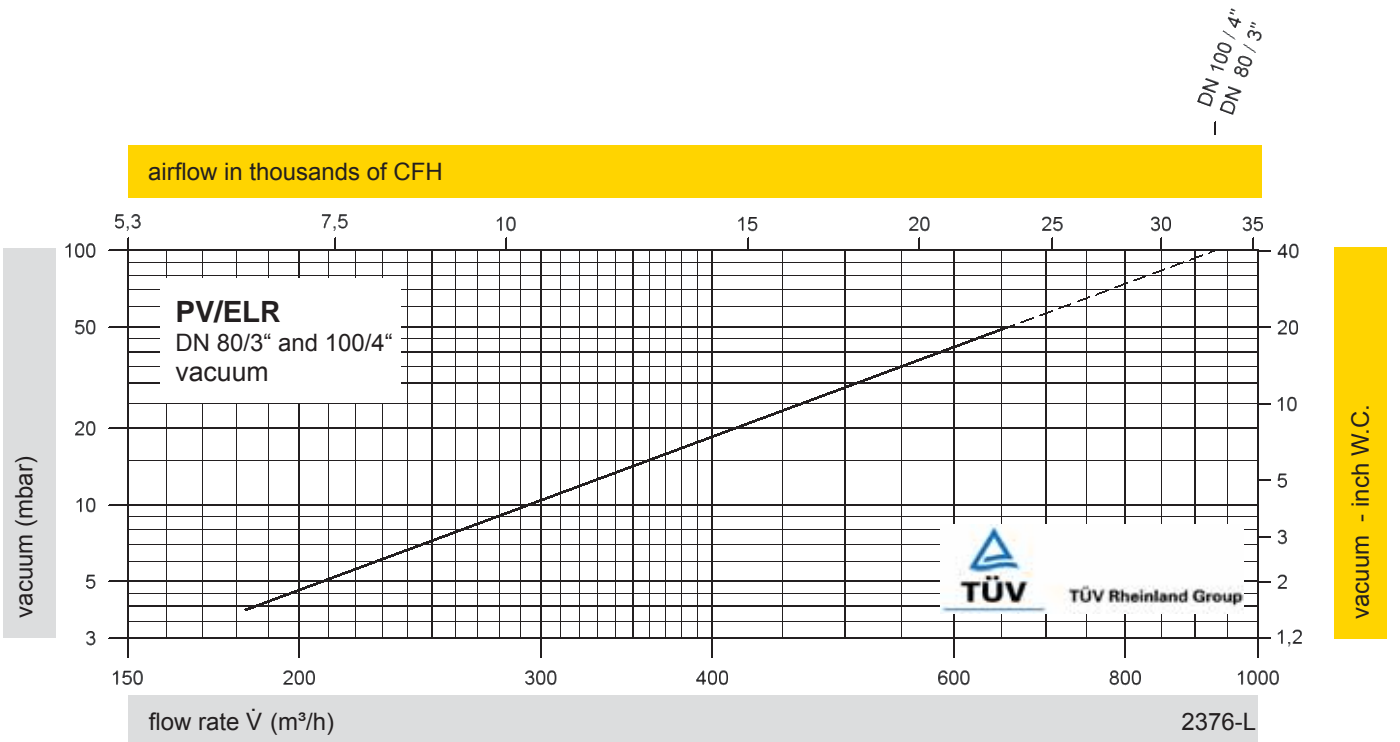
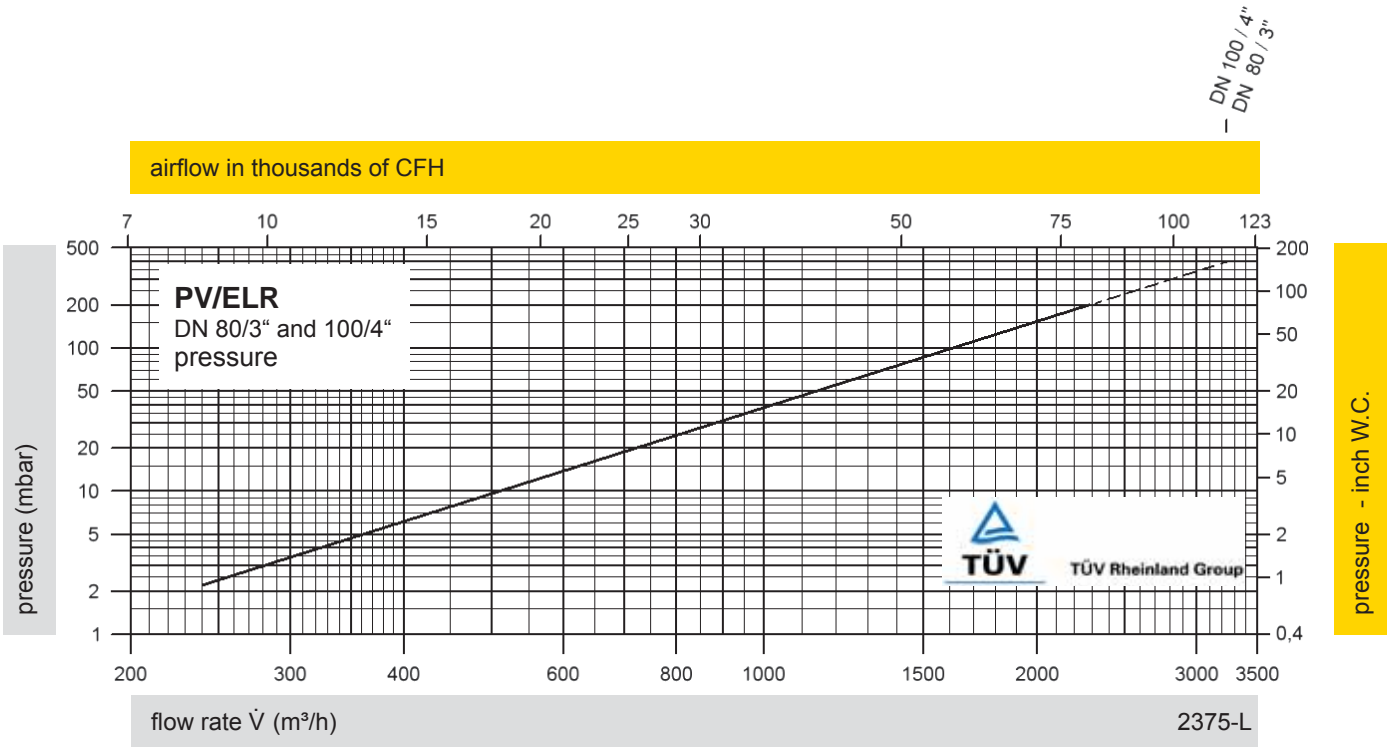

The flow capacity charts have been determined with a calibrated and TÜV certified flow capacity test rig. Volume flow \dot{V} in (m³/h) and CFH refer to the standard reference conditions of air ISO 6358 (20°C, 1bar). Conversion to other densities and temperatures refer to Vol. 1: "Technical Fundamentals".



Pressure and Vacuum Relief Valve

PROTEGO® VD/SV

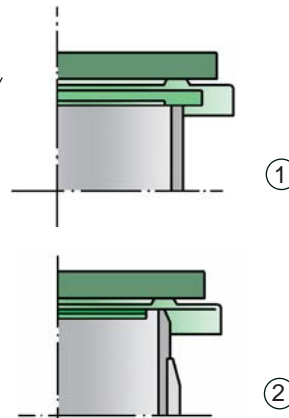
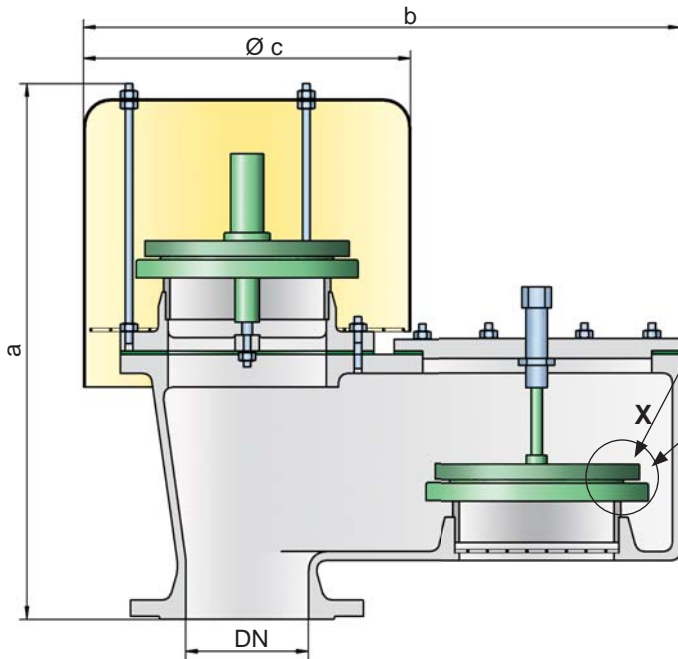

Settings:

Pressure: +2.0 mbar up to +60 mbar
+0.8 inch W.C. up to +24 inch W.C.

Vacuum: -2.0 mbar up to -60 mbar
-0.8 inch W.C. up to -24 inch W.C.

Higher or lower settings upon request.

Function and Description

The VD/SV type PROTEGO® valve is a highly developed pressure and vacuum relief valve with excellent flow performance. Typically the valve is installed in the in- and outbreathing lines of tanks, vessels and process apparatus to protect against unallowable high and low pressure. The valve prevents emission losses almost up to the set pressure and prevents air intake almost up to set vacuum.

The device will start to open as soon as the set pressure is reached and only requires 10% overpressure to full lift. Continuous investments into research and development have allowed PROTEGO® to develop a low pressure valve which has the same opening characteristic as a high pressure safety relief valve. This "full lift type" technology allows the valve to be set just 10% below the maximum allowable working pressure or vacuum (MAWP or MAWV) of the tank and still safely vent the required mass flow. The opening characteristic is the same for pressure and vacuum relief.

Due to our highly developed manufacturing technology the tank pressure is maintained up to set pressure with a tightness that is far superior to the conventional standard. This feature is achieved by valve seats made of high quality stainless steel and with precisely lapped valve pallets (1) or with an air cushion seal (2) in conjunction with high quality FEP diaphragm. The valve pallets are also available with a PTFE seal to prevent the valve pallets from sticking when sticky products are used and to enable the use of corrosive fluids. After the excess pressure is discharged or the vacuum is compensated, the valve reseats and provides a tight seal.

The optimized fluid dynamic design of the valve body and valve pallet is a result of many years of research work, which allow a stable operation of the valve pallet and optimized performance resulting in reduction of product losses.

Special Features and Advantages

- "full lift type" technology valve utilizes only 10% overpressure to reach full lift
- extreme tightness and hence least possible product losses and reduced environmental pollution
- the set pressure is close to the opening pressure which results in best possible pressure management of the system
- very high flow capacity
- the valve pallet is guided within the housing to protect against harsh weather conditions
- can be used in areas subject to explosion hazards
- self draining
- maintenance friendly design
- best technology for API-tanks

Design Types and Specifications

The valve pallets are weight-loaded. Higher pressures can be achieved upon request with a special spring-loaded design.

There are two different designs:

Pressure/vacuum valve in basic design **VD/SV-**

Pressure/vacuum relief valve with heating jacket **VD/SV-** **H**

Additional special devices available upon request.

Any combination of vacuum and pressure levels can be set for the valve. When the difference between the pressure and vacuum exceeds 150 mbar / 60.2 inch W.C., special valve pallets are used.

Table 1: Dimensions

Dimensions in mm / inches

To select the nominal size (DN), use the flow capacity chart on the following page

DN	40 / 1 1/2"	50 / 2"	80 / 3"	100 / 4"	150 / 6"	200 / 8"	250 / 10"	300 / 12"
a	396 / 15.59	396 / 15.59	497 / 19.57	519 / 20.43	654 / 25.75	757 / 29.80	802 / 31.57	802 / 31.57
b	355 / 13.98	355 / 13.98	448 / 17.64	548 / 21.57	788 / 31.02	900 / 35.43	1030 / 40.55	1030 / 40.55
c	200 / 7.87	200 / 7.87	295 / 11.61	295 / 11.61	465 / 18.31	550 / 21.65	650 / 25.59	650 / 25.59

Dimensions of pressure and vacuum relief valves with heating jacket upon request

Table 2: Material selection for housing

Design	A	B	C	
Housing	Aluminium	Steel	Stainless Steel	Option: Housing ECTFE-coated
Heating jacket (VD/SV-H-...)	-	Steel	Stainless Steel	
Valve seat	Stainless Steel	Stainless Steel	Stainless Steel	Special materials upon request
Sealing	PTFE	PTFE	PTFE	
Weather hood	Stainless Steel	Stainless Steel	Stainless Steel	

Table 3: Material selection for pressure valve pallet

Design	A	B	C	D	E	F
Pressure range (mbar) (inch W.C.)	+2.0 up to +3.5 +0.8 up to +1.4	>+3.5 up to +14 >+1.4 up to +5.6	>+14 up to +35 >+5.6 up to +14	>+35 up to +60 >+14 up to +24	>+14 up to +35 >+5.6 up to +14	>+35 up to +60 >+14 up to +24
Valve pallet	Aluminium	Stainless Steel	Stainless Steel	Stainless Steel	Stainless Steel	Stainless Steel
Sealing	FEP	FEP	Metal to metal	Metal to metal	PTFE	PTFE

Special material as well as higher set pressure upon request

Table 4: Material selection for vacuum valve pallet

Design	A	B	C	D	E	F
Vacuum range (mbar) (inch W.C.)	-2.0 up to -3.5 -0.8 up to -1.4	<-3.5 up to -14 <-1.4 up to -5.6	<-14 up to -35 <-5.6 up to -14	<-14 up to -35 <-5.6 up to -14	<-35 up to -60 <-14 up to -24	<-35 up to -60 <-14 up to -24
Valve pallet	Aluminium	Stainless Steel	Stainless Steel	Stainless Steel	Stainless Steel	Stainless Steel
Sealing	FEP	FEP	Metal to Metal	PTFE	Metal to Metal	PTFE

Special material as well as higher vacuum upon request

Table 5: Flange connection type

EN 1092-1, Form B1 or DIN 2501, Form C, PN 16; from DN 200 PN 10	EN or DIN	other types upon request
ANSI 150 lbs RFSF	ANSI	



for safety and environment



Pressure and Vacuum Relief Valve

Flow Capacity Charts

PROTEGO® VD/SV

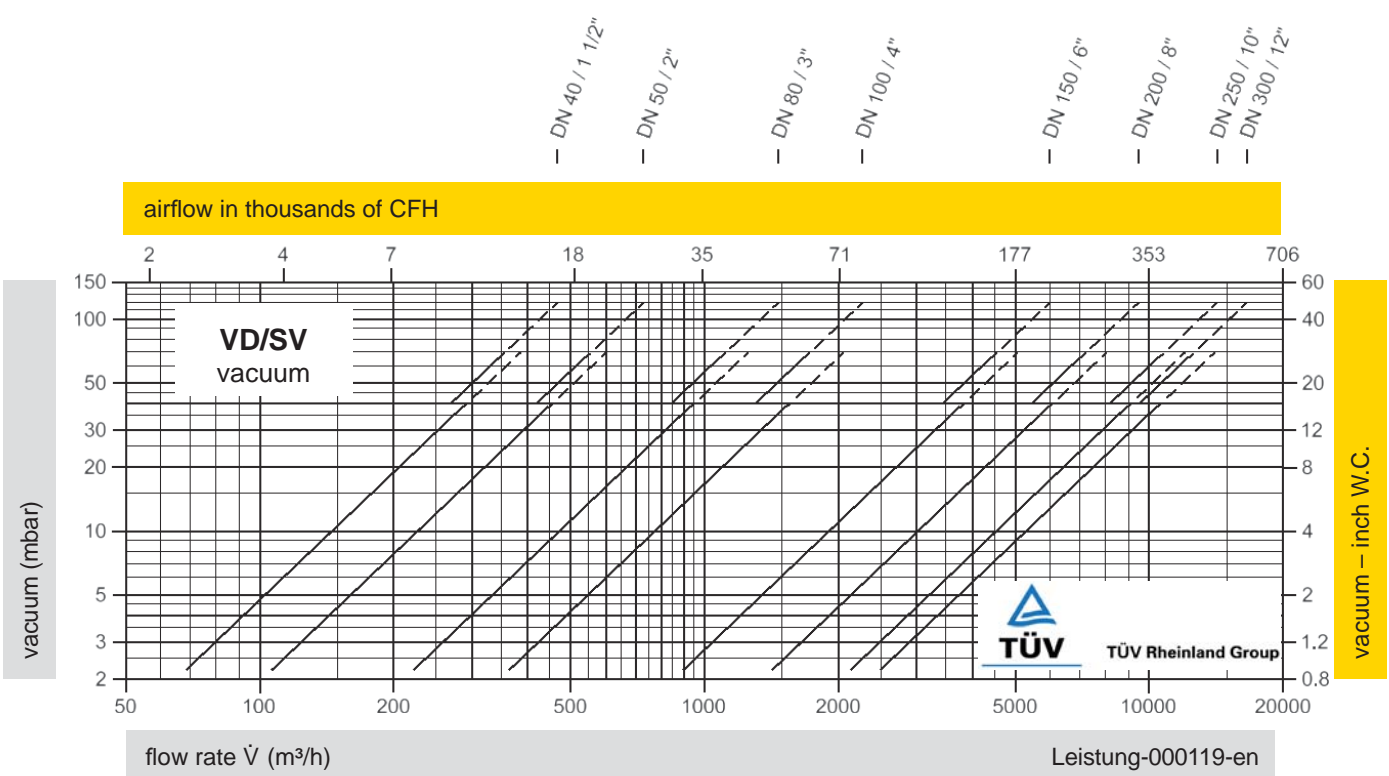
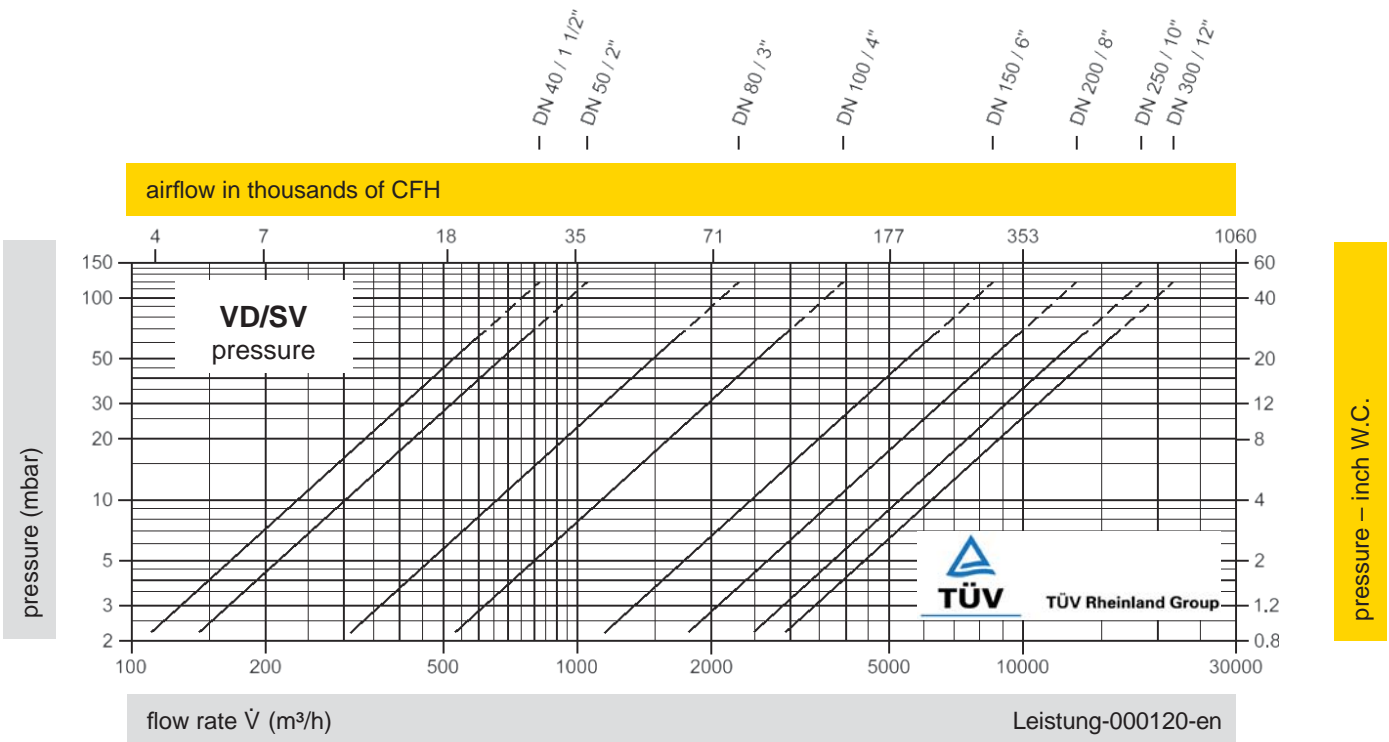

The flow capacity charts have been determined with a calibrated and TÜV certified flow capacity test rig. Volume flow \dot{V} in (m³/h) and CFH refer to the standard reference conditions of air ISO 6358 (20°C, 1bar). Conversion to other densities and temperatures refer to Vol. 1: "Technical Fundamentals".



Pressure and Vacuum Relief Valve with pipe-away connection

PROTEGO® VD/SV-PA(L)

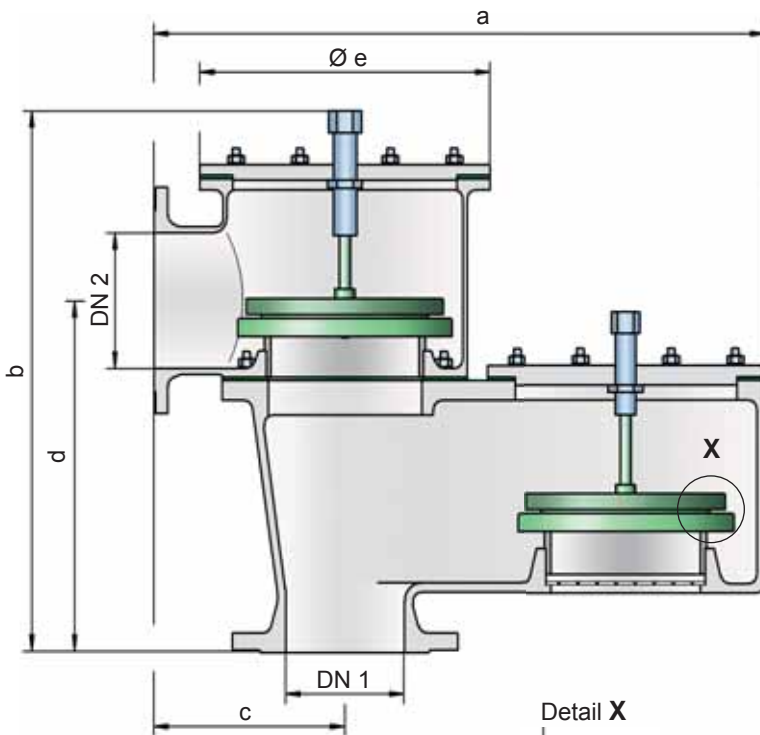

Settings:

Pressure: +2.0 mbar up to +60 mbar
+0.8 inch W.C. up to +24 inch W.C.

Vacuum: -2.0 mbar up to -60 mbar
-0.8 inch W.C. up to -24 inch W.C.

Higher or lower settings upon request.

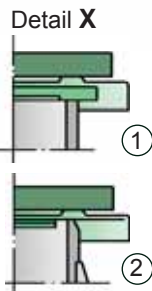

valve seats made of high quality stainless steel and with precisely lapped valve pallets (1) or with an air cushion seal (2) in conjunction with high quality FEP diaphragm. The valve pallets are also available with a PTFE seal to prevent the valve pallets from sticking when sticky products are used and to enable the use of corrosive fluids. After the excess pressure is discharged or the vacuum is compensated, the valve reseats and provides a tight seal.

The optimized fluid dynamic design of the valve body and valve pallet is a result of many years of research work, which allow a stable operation of the valve pallet and optimized performance resulting in reduction of product losses.

Special Features and Advantages

- “full lift type” technology valve utilizes only 10% overpressure to reach full lift
- extreme tightness and hence least possible product losses and reduced environmental pollution
- set pressure is close to the opening pressure which results in best possible pressure management of the system
- very high flow capacity
- can be used in areas subject to explosion hazards
- self draining
- maintenance friendly design
- best technology for API-tanks

Function and Description

The VD/SV-PA(L) type PROTEGO® valve is a highly developed pressure and vacuum relief valve with excellent flow performance. Typically the valve is installed in the in- and outbreathing lines of tanks, vessels and process apparatus to protect against unallowable high and low pressure. The valve prevents emission losses almost up to the set pressure and prevents air intake almost up to set vacuum. The product vapors can be discharged through a collective line connected to the line flange on the pressure side.

The device will start to open as soon as the set pressure is reached and only requires 10% overpressure to full lift. Continuous investments into research and development have allowed PROTEGO® to develop a low pressure valve which has the same opening characteristic as a high pressure safety relief valve. This “full lift type” technology allows the valve to be set just 10% below the maximum allowable working pressure or vacuum (MAWP or MAWV) of the tank and still safely vent the required mass flow. The opening characteristic is the same for pressure and vacuum relief.

Due to our highly developed manufacturing technology the tank pressure is maintained up to set pressure with a tightness that is far superior to the conventional standard. This feature is achieved by

Design Types and Specifications

The valve pallets are weight-loaded. Higher pressures can be achieved upon request with a special spring-loaded design. Choose the model (L) if the discharge nozzle has a nominal diameter that is greater than the nominal diameter of the tank filler neck.

There are four different designs:

- | | |
|---|---|
| Pressure/vacuum valve in basic design | VD/SV-PA - <input type="checkbox"/> |
| Pressure/vacuum valve with heating jacket | VD/SV-PA - <input type="checkbox"/> H |
| Pressure/vacuum relief valve with DN2 > DN1 | VD/SV-PAL- <input type="checkbox"/> |
| Pressure/vacuum relief valve with DN2 > DN1 with heating jacket | VD/SV-PAL- <input type="checkbox"/> H |

Additional special devices available upon request.

Any combination of vacuum and pressure setting can be achieved for the valve. When the difference between the pressure and vacuum exceeds 150 mbar (60.2 inch W.C.), special valve pallets are used.

Table 1: Dimensions

Dimensions in mm / inches

To select the nominal size (DN), use the flow capacity charts on the following pages

VD/SV-PA

DN 1	50 / 2"	80 / 3"	100 / 4"	150 / 6"	200 / 8"	250 / 10"	300 / 12"
DN 2	50 / 2"	80 / 3"	100 / 4"	150 / 6"	200 / 8"	250 / 10"	300 / 12"
a	405 / 15.95	480 / 18.90	600 / 23.62	805 / 31.69	925 / 36.42	1010 / 39.76	1010 / 39.76
b	390 / 15.35	485 / 19.09	550 / 21.65	660 / 25.98	780 / 30.71	875 / 34.45	875 / 34.45
c	150 / 5.91	180 / 7.09	200 / 7.87	250 / 9.84	300 / 11.81	305 / 12.01	305 / 12.01
d	240 / 9.45	300 / 11.81	330 / 12.99	390 / 15.35	480 / 18.90	555 / 21.85	582 / 22.91
e	165 / 6.50	192 / 7.56	240 / 9.45	350 / 13.78	390 / 15.35	460 / 18.11	460 / 18.11

VD/SV-PAL

DN 1	50 / 2"	80 / 3"	100 / 4"	150 / 6"	200 / 8"	250 / 10"	300 / 12"
DN 2	80 / 3"	100 / 4"	150 / 6"	200 / 8"	250 / 10"	300 / 12"	350 / 14"
a	395 / 15.55	445 / 17.52	565 / 22.24	770 / 30.31	895 / 35.24	1010 / 39.76	1010 / 39.76
b	400 / 15.74	485 / 19.09	550 / 21.65	655 / 25.79	775 / 30.51	875 / 34.45	885 / 34.45
c	140 / 5.51	143 / 5.63	165 / 6.50	216 / 8.50	267 / 10.51	305 / 12.01	305 / 12.01
d	255 / 10.04	308 / 12.13	355 / 13.98	417 / 16.42	505 / 19.88	582 / 22.91	603 / 23.74
e	165 / 6.50	192 / 7.56	240 / 9.45	350 / 13.78	390 / 15.35	460 / 18.11	460 / 18.11

Dimensions of pressure and vacuum relief valves with heating jacket upon request

Table 2: Material selection for housing

Design	A	B	C	
Housing	Aluminium	Steel	Stainless Steel	Option: Housing with ECTFE-lining
Heating jacket (VD/SV-PA(L)-H-...)	-	Steel	Stainless Steel	
Valve seat	Stainless Steel	Stainless Steel	Stainless Steel	Special materials upon request
Sealing	PTFE	PTFE	PTFE	

Table 3: Material selection for pressure valve pallet

Design	A	B	C	D	E	F
Pressure range (mbar)	+2.0 up to +3.5	>+3.5 up to +14	>+14 up to +35	>+35 up to +60	>+14 up to +35	>+35 up to +60
(inch W.C.)	+0.8 up to +1.4	>+1.4 up to +5.6	>+5.6 up to +14	>+14 up to +24	>+5.6 up to +14	>+14 up to +24
Valve pallet	Aluminium	Stainless Steel	Stainless Steel	Stainless Steel	Stainless Steel	Stainless Steel
Sealing	FEP	FEP	Metal to Metal	Metal to Metal	PTFE	PTFE

Special material (alu-coated, titan, hastelloy) as well as higher set pressure upon request

Table 4: Material selection for vacuum valve pallet

Design	A	B	C	D	E	F
Vacuum range (mbar)	-2.0 up to -3.5	<-3.5 up to -14	<-14 up to -35	<-35 up to -60	<-14 up to +35	<-35 up to -60
(inch W.C.)	-0.8 up to -1.4	<-1.4 up to -5.6	<-5.6 up to -14	<-14 up to -24	<-5.6 up to +14	<-14 up to -24
Valve pallet	Aluminium	Stainless Steel	Stainless Steel	Stainless Steel	Stainless Steel	Stainless Steel
Sealing	FEP	FEP	Metal to Metal	Metal to Metal	PTFE	PTFE

Special material (alu-coated, titan, hastelloy) as well as higher set vacuum upon request

Table 5: Flange connection type

EN 1092-1, Form B1 or DIN 2501, Form C, PN 16; from DN 200 PN 10	EN or DIN	other types upon request
ANSI 150 lbs RFSF	ANSI	



for safety and environment

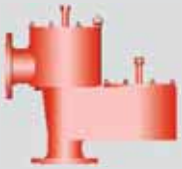

Pressure and Vacuum Relief Valve
Flow Capacity Charts

PROTEGO® VD/SV-PA(L)

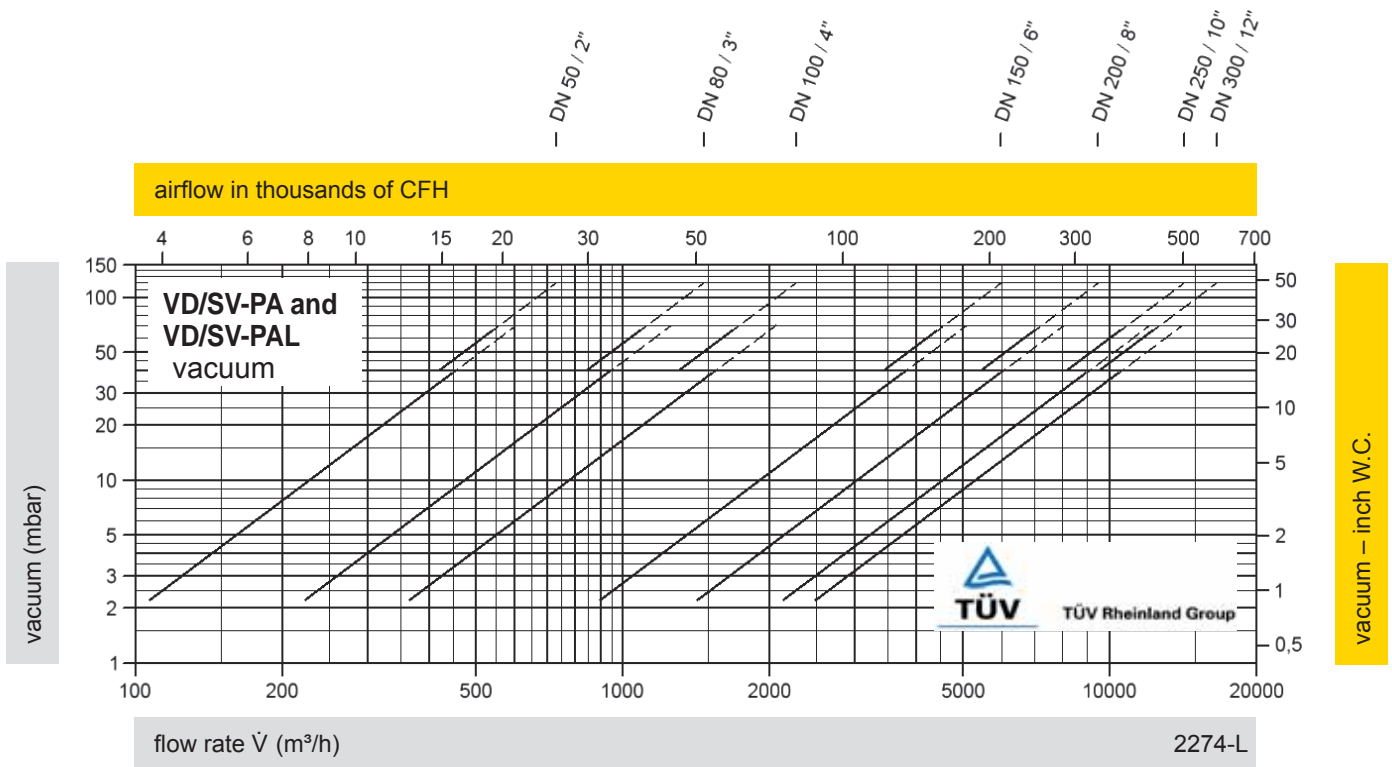

The flow capacity charts have been determined with a calibrated and TÜV certified flow capacity test rig. Volume flow \dot{V} in (m³/h) and CFH refer to the standard reference conditions of air ISO 6358 (20°C, 1bar). Conversion to other densities and temperatures refer to Vol. 1: "Technical Fundamentals".

PROTEGO® VD/SV-PA(L)

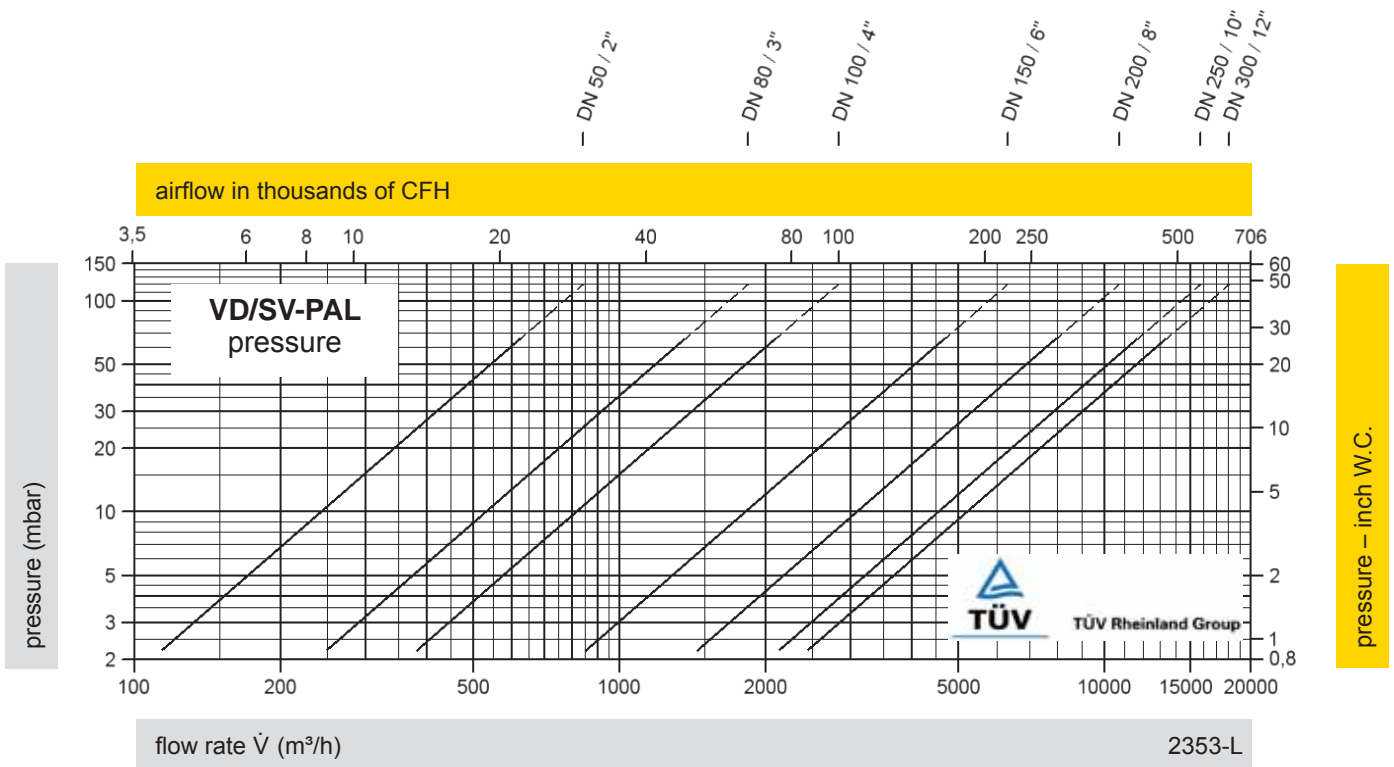
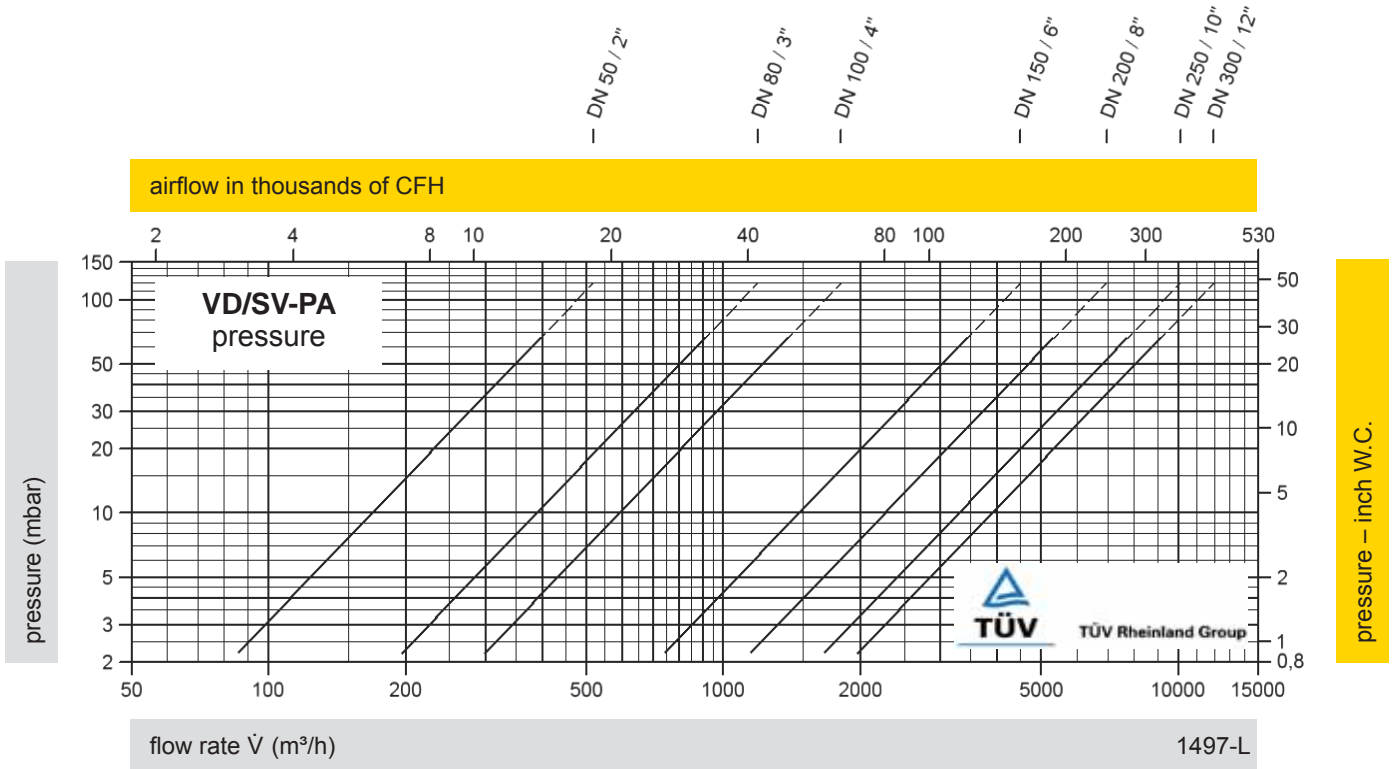

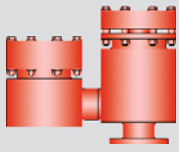

Pressure and Vacuum Relief Valve

made of plastic

PROTEGO® VD/KSM

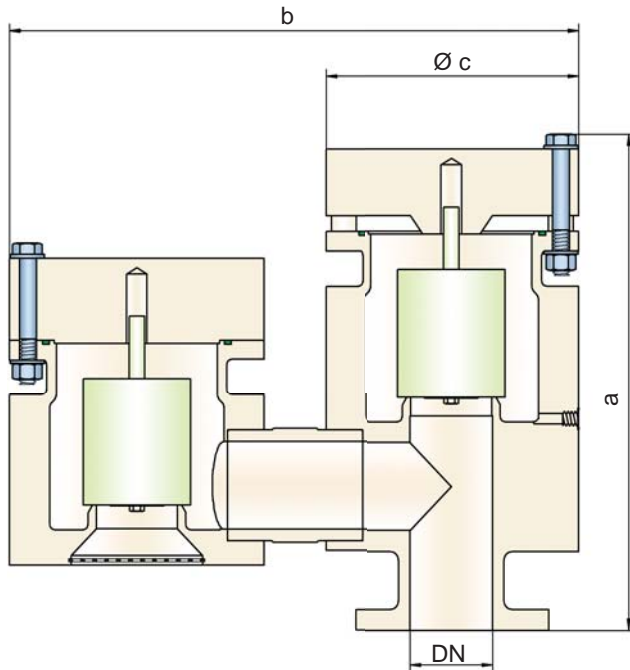

Settings:

Pressure:

+6.0 mbar	up to +100 mbar (DN 50/2")
+2.4 inch W.C.	up to +40 inch W.C.
+4.0 mbar	up to +100 mbar (DN 80/3")
+1.6 inch W.C.	up to +40 inch W.C.
+4.5 mbar	up to +100 mbar (DN 100/4" - DN 200/8")
+1.8 inch W.C.	up to +40 inch W.C.

Vacuum:

-6.0 mbar	up to -100 mbar (DN 50/2")
-2.4 inch W.C.	up to -40 inch W.C.
-4.0 mbar	up to -100 mbar (DN 80/3")
-1.6 inch W.C.	up to -40 inch W.C.
-4.5 mbar	up to -100 mbar (DN 100/4" - DN 200/8")
-1.8 inch W.C.	up to -40 inch W.C.

Higher and lower settings upon request

Function and Description

The PROTEGO® valve VD/KSM is a state-of-the-art pressure and vacuum relief valve with excellent flow performance made of highgrade synthetic material. Typically the valve is installed in the in- and out-breathing lines of tanks, vessels and process apparatus to protect against unallowable high or low pressure. The valve prevents emission losses almost up to the set pressure. The valve is a perfect solution for corrosive, polymerizing or sticky media.

The device will start to open as soon as the set pressure is reached and only requires 10% overpressure to full lift. Continuous investments into research and development have allowed PROTEGO® to develop a low pressure valve which has the same opening characteristic as a high pressure safety relief valve. This "full lift type" technology allows the valve to be set just 10% below the maximum allowable working pressure and vacuum (MAWP and MAWV) of the tank and still safely vent the required mass flow. The opening characteristic for pressure and vacuum side is the same.

Due to our highly developed manufacturing technology the tank pressure is maintained up to set pressure with a tightness that is far superior to the conventional standard. This feature is achieved by special valve seats made of high quality synthetic material or PTFE. After the excess pressure is discharged or vacuum is compensated, the valve reseats and provides a tight seal.

The optimized fluid dynamic design of the valve body and valve pallet is a result of many years of research work, which allow a stable operation of the valve pallet and optimized performance resulting in reduction of product losses.

Special Features and Advantages

- "full lift type" technology valve utilizes only 10% overpressure to reach full lift
- extreme tightness and hence least possible product losses and reduced environmental pollution
- the set pressure is close to the opening pressure which results in best possible pressure management of the system
- the valve pallet is guided within the housing to protect against harsh weather conditions
- corrosion resistant valve
- perfect solution for corrosive, polymerizing and sticky media
- weight reduction in comparison to steel/stainless steel
- vacuum side self draining and pressure side condensate drain
- smooth surface
- different plastics can be combined
- maintenance friendly design

Design Types and Specifications

The valve pallets are weight-loaded, and the highest pressure levels are only attained with metal discs.

Pressure/vacuum valve in basic design **VD/KSM-**

Additional special devices available upon request.

Table 1: Dimensions

Dimensions in mm / inches

To select the nominal size (DN), use the flow capacity chart on the following page

DN	50 / 2"	80 / 3"	100 / 4"	150 / 6"	200 / 8"
a	376 / 14.80	521 / 20.51	563 / 22.17 (542 / 21.34)*	670 / 26.38 (681 / 26.81)*	917 / 36.10 (952 / 37.48)*
b	430 / 16.93	575 / 22.64	700 / 27.56 (675 / 26.57)*	825 / 32.48 (880 / 34.65)*	1190 / 46.85 (1100 / 43.31)*
c	180 / 7.09	250 / 9.84	300 / 11.81	350 / 13.78 (405 / 15.94)*	560 / 22.05 (500 / 19.68)*

* Dimensions in brackets only for PVDF

Table 2: Material selection for the housing

Design	A	B	C	
Housing	PE	PP	PVDF	Special Materials upon request
Valve seat	PE	PP	PVDF	
Sealing	FPM	FPM	FPM	
Pressure valve pallet	A, C, D	B, C, D	C, D	
Vacuum valve pallet	A, C, D	B, C, D	C, D	

Table 3: Material selection for pressure valve pallet

Design	A	B	C	D
Pressure range (mbar) (inch W.C.)	+6.0 up to +16 +2.4 up to +6.4	+5.5 up to +16 +2.2 up to +6.4	+9.5 up to +30 +3.8 up to +12	+30 up to +100 +12 up to +40
Valve pallet	PE	PP	PVDF	Hastelloy
Sealing	PTFE	PTFE	PTFE	PTFE
Spindle guide	PE	PP	PVDF	Hastelloy
Weight	PE	PP	PVDF	Hastelloy

Special materials and other pressure settings are available upon request

Table 4: Material selection for vacuum valve pallet

Design	A	B	C	D
Vacuum range (mbar) (inch W.C.)	-6.0 up to -16 -2.4 up to -6.4	-5.5 up to -16 -2.2 up to -6.4	-9.5 up to -30 -3.8 up to -12	-30 up to -100 -12 up to -40
Valve pallet	PE	PP	PVDF	Hastelloy
Sealing	PTFE	PTFE	PTFE	PTFE
Spindle guide	PE	PP	PVDF	Hastelloy
Weight	PE	PP	PVDF	Hastelloy

Special materials and other vacuum settings are available upon request

Table 5: Flange connection type

EN 1092-1, Form A or DIN 2501, Form B, PN 16; from DN 200 PN 10	EN or DIN	other types upon request
ANSI 150 lbs FFSF	ANSI	



for safety and environment

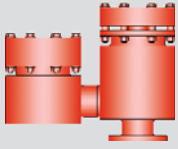

Pressure and Vacuum Relief Valve

Flow Capacity Charts

PROTEGO® VD/KSM

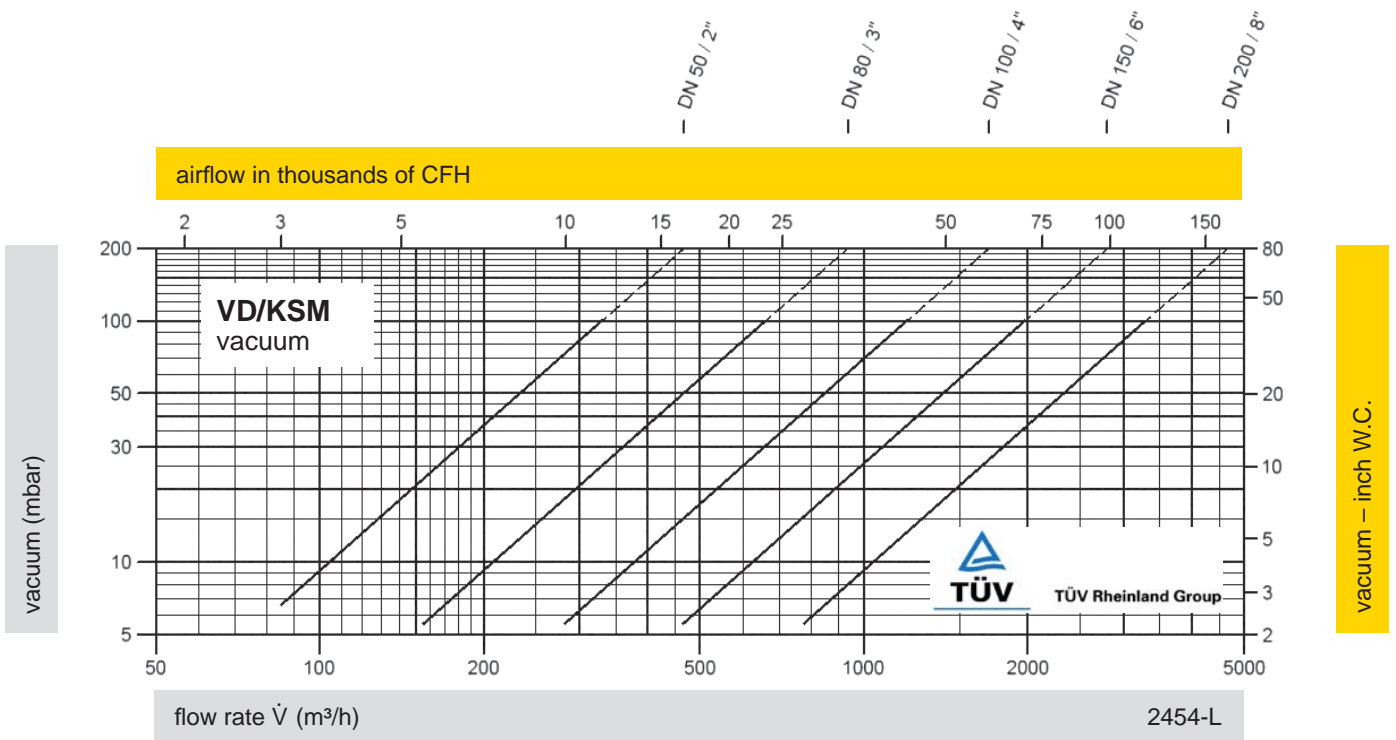
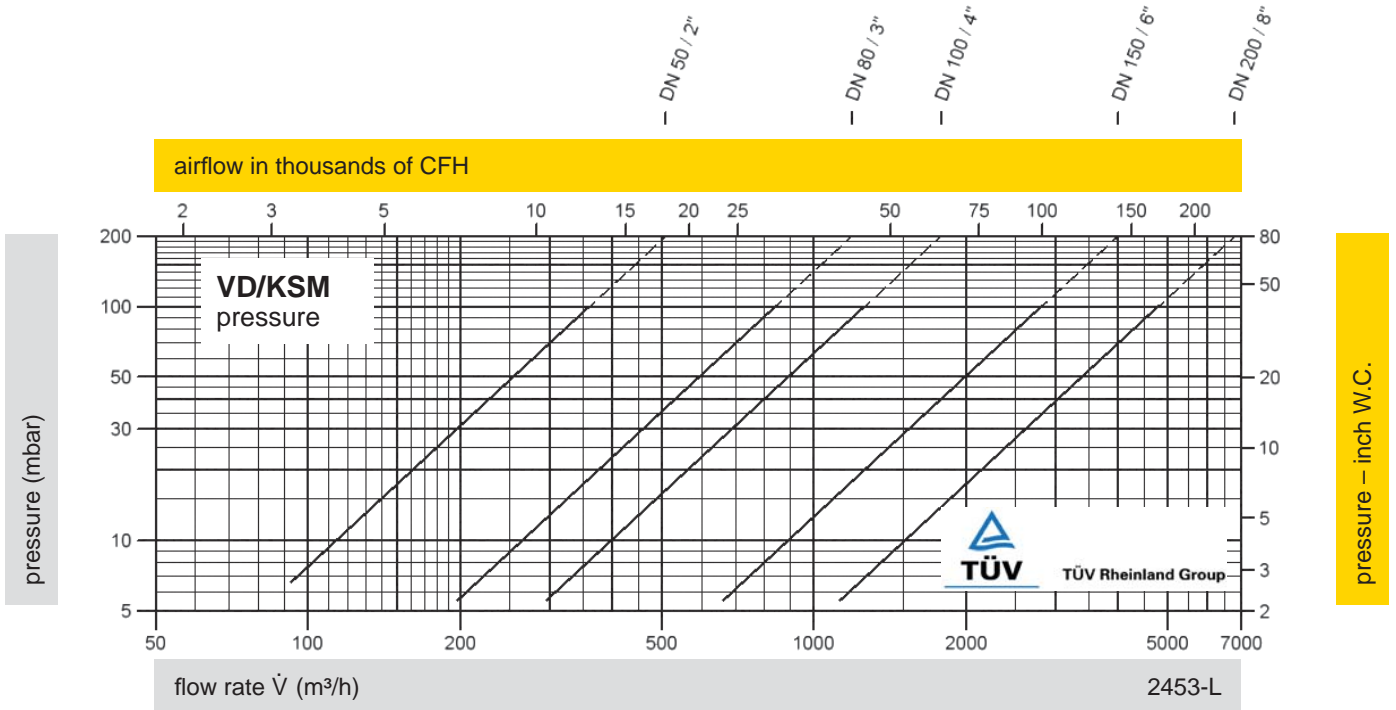

The flow capacity charts have been determined with a calibrated and TÜV certified flow capacity test rig. Volume flow \dot{V} in (m³/h) and CFH refer to the standard reference conditions of air ISO 6358 (20°C, 1bar). Conversion to other densities and temperatures refer to Vol. 1: "Technical Fundamentals".

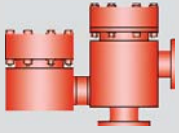

Pressure and Vacuum Relief Valve

made of plastic

PROTEGO® VD/KSM-PA

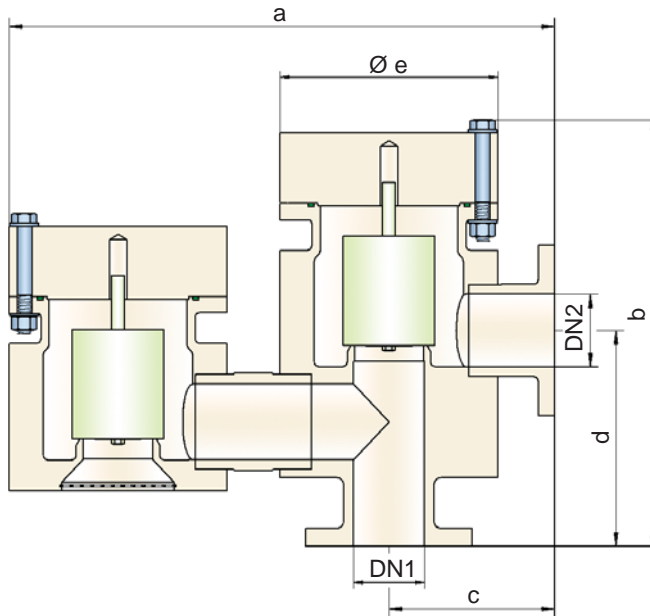

Settings:

Pressure:

+6.0 mbar	up to	+100 mbar (DN 50/2")
+2.4 inch W.C.	up to	+40 inch W.C.
+4.0 mbar	up to	+100 mbar (DN 80/3")
+1.6 inch W.C.	up to	+40 inch W.C.
+4.5 mbar	up to	+100 mbar (DN 100/4" - DN 200/8")
+1.8 inch W.C.	up to	+40 inch W.C.

Vacuum:

-6.0 mbar	up to	-100 mbar (DN 50/2")
-2.4 inch W.C.	up to	-40 inch W.C.
-4.0 mbar	up to	-100 mbar (DN 80/3")
-1.6 inch W.C.	up to	-40 inch W.C.
-4.5 mbar	up to	-100 mbar (DN 100/4" - DN 200/8")
-1.8 inch W.C.	up to	-40 inch W.C.

Higher and lower settings upon request

Function and Description

The PROTEGO® valve VD/KSM-PA is a state-of-the-art pressure and vacuum relief valve with excellent flow performance made of highgrade synthetic material. Typically the valve is installed in the in- and out-breathing lines of tanks, vessels and process apparatus to protect against unallowable high or low pressure. The valve prevents emission losses almost up to the set pressure. The valve is a perfect solution for corrosive, polymerizing or sticky media.

The device will start to open as soon as the set pressure is reached and only requires 10% overpressure to full lift. Continuous investments into research and development have allowed PROTEGO® to develop a low pressure valve which has the same opening characteristic as a high pressure safety relief valve. This "full lift type" technology allows the valve to be set just 10% below the maximum allowable working pressure and vacuum (MAWP and MAWV) of the tank and still safely vent the required mass flow. The opening characteristic for pressure and vacuum side is the same.

Due to our highly developed manufacturing technology the tank pressure is maintained up to set pressure with a tightness that is far superior to the conventional standard. This feature is achieved by special valve seats made of high quality synthetic material or PTFE. After the excess pressure is discharged or vacuum is compensated, the valve reseats and provides a tight seal.

The optimized fluid dynamic design of the valve body and valve pallet is a result of many years of research work, which allow a stable operation of the valve pallet and optimized performance resulting in reduction of product losses.

Special Features and Advantages

- "full lift type" technology valve utilizes only 10% overpressure to reach full lift
- extreme tightness and hence least possible product losses and reduced environmental pollution
- the set pressure is close to the opening pressure which results in best possible pressure management of the system
- the valve pallet is guided within the housing to protect against harsh weather conditions
- corrosion resistant valve
- perfect solution for corrosive, polymerizing and sticky media
- weight reduction in comparison to steel/stainless steel
- vacuum side self draining and pressure side condensate drain
- smooth surface
- different plastics can be combined
- maintenance friendly design

Design Types and Specifications

The valve pallets are weight-loaded, and the highest pressure levels are only attained with metal discs.

Pressure/vacuum valve in basic design **VD/KSM-PA-**

Additional special devices available upon request.

Table 1: Dimensions

Dimensions in mm / inches

To select the nominal size (DN), use the flow capacity chart on the following page

DN1	50 / 2"	80 / 3"	100 / 4"	150 / 6"	200 / 8"
DN2	50 / 2"	80 / 3"	100 / 4"	150 / 6"	200 / 8"
a	490 / 19.29	650 / 25.59	775 / 30.51 (750 / 29.53)*	930 / 36.61 (958 / 37.72)*	1260 / 49.61 (1200 / 47.24)*
b	376 / 14.80	521 / 20.51	563 / 22.17 (523 / 20.59)*	670 / 26.38 (651 / 25.63)*	879 / 34.61 (912 / 35.91)*
c	150 / 5.91	200 / 7.87	225 / 8.86	280 / 11.02	350 / 13.78
d	200 / 7.87	245 / 9.65	300 / 11.81	370 / 14.57	590 / 23.23 (650 / 25.59)*
e	180 / 7.09	250 / 9.84	300 / 11.81	350 / 13.78 (405 / 15.94)*	560 / 22.05 (500 / 19.68)*

* Dimensions in brackets only for PVDF

Table 2: Material selection for the housing

Design	A	B	C	
Housing	PE	PP	PVDF	Special Materials upon request
Valve seat	PE	PP	PVDF	
Sealing	FPM	FPM	FPM	
Pressure valve pallet	A, C, D	B, C, D	C, D	
Vacuum valve pallet	A, C, D	B, C, D	C, D	

Table 3: Material selection for pressure valve pallet

Design	A	B	C	D
Pressure range (mbar) (inch W.C.)	+6.0 up to +16 +2.4 up to +6.4	+5.5 up to +16 +2.2 up to +6.4	+9.5 up to +30 +3.8 up to +12	+30 up to +100 +12 up to +40
Valve pallet	PE	PP	PVDF	Hastelloy
Sealing	PTFE	PTFE	PTFE	PTFE
Spindle guide	PE	PP	PVDF	Hastelloy
Weight	PE	PP	PVDF	Hastelloy

Special materials and other pressure settings are available upon request

Table 4: Material selection for vacuum valve pallet

Design	A	B	C	D
Vacuum range (mbar) (inch W.C.)	-6.0 up to -16 -2.4 up to -6.4	-5.5 up to -16 -2.2 up to -6.4	-9.5 up to -30 -3.8 up to -12	-30 up to -100 -12 up to -40
Valve pallet	PE	PP	PVDF	Hastelloy
Sealing	PTFE	PTFE	PTFE	PTFE
Spindle guide	PE	PP	PVDF	Hastelloy
Weight	PE	PP	PVDF	Hastelloy

Special materials and other vacuum settings are available upon request

Table 5: Flange connection type

EN 1092-1, Form A or DIN 2501, Form B, PN 16; from DN 200 PN 10	EN or DIN	other types upon request
ANSI 150 lbs FFSS	ANSI	



for safety and environment

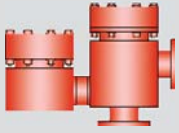

Pressure and Vacuum Relief Valve

Flow Capacity Charts

PROTEGO® VD/KSM-PA

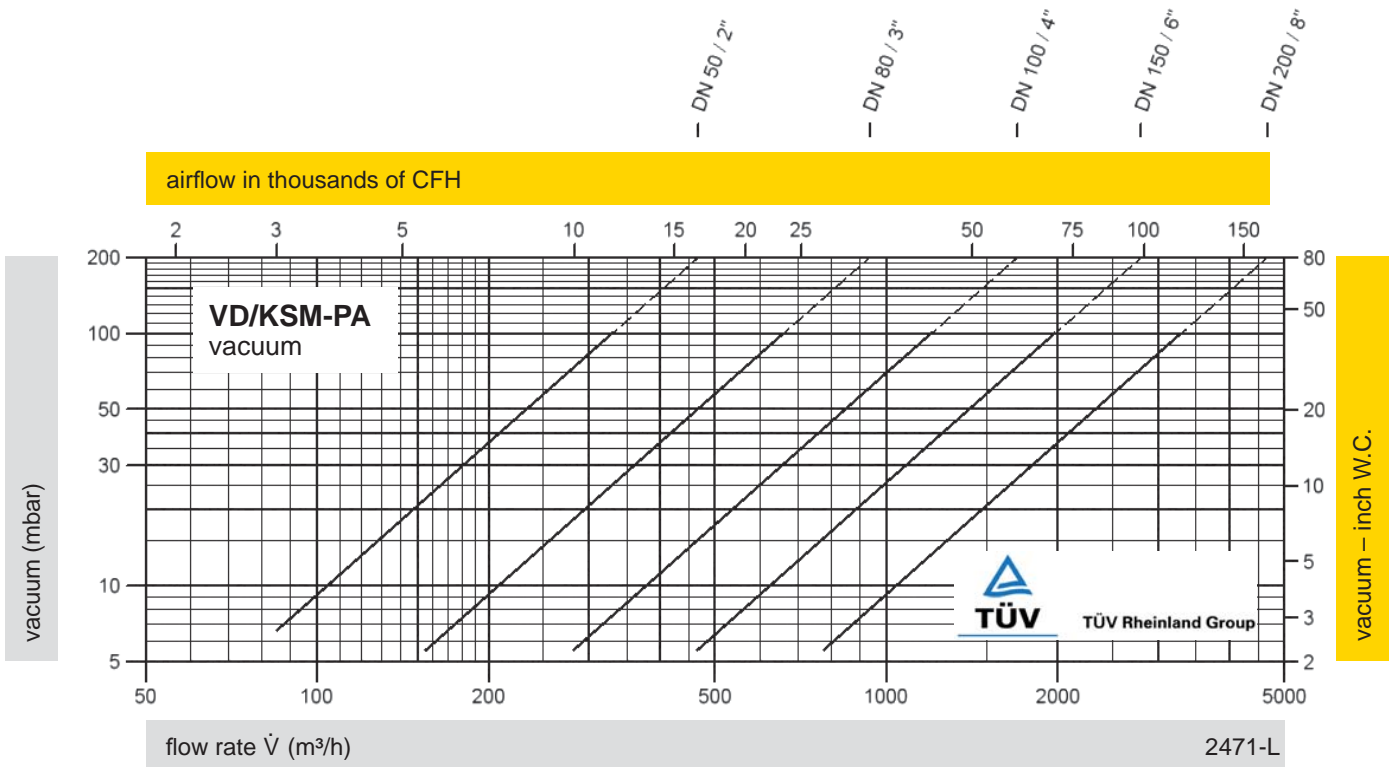
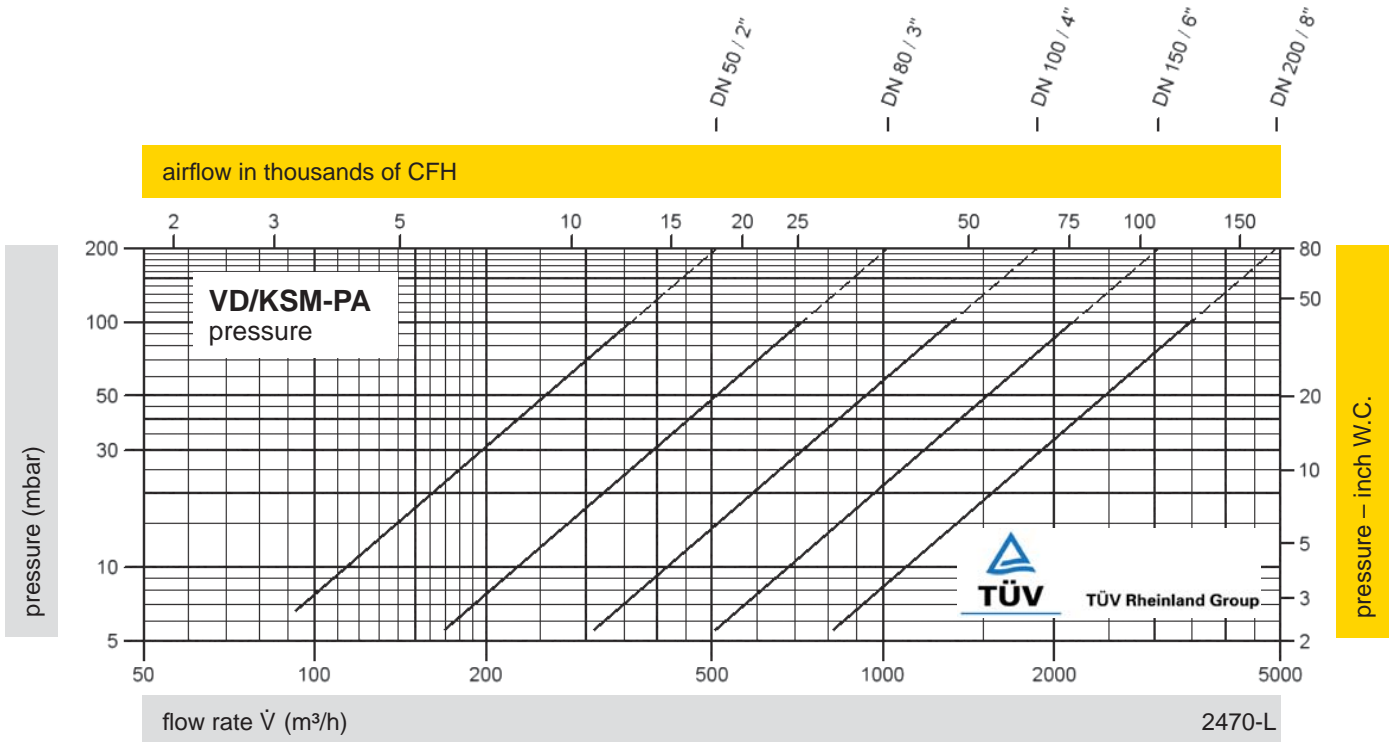

The flow capacity charts have been determined with a calibrated and TÜV certified flow capacity test rig. Volume flow \dot{V} in (m³/h) and CFH refer to the standard reference conditions of air ISO 6358 (20°C, 1bar). Conversion to other densities and temperatures refer to Vol. 1: "Technical Fundamentals".

Notes:

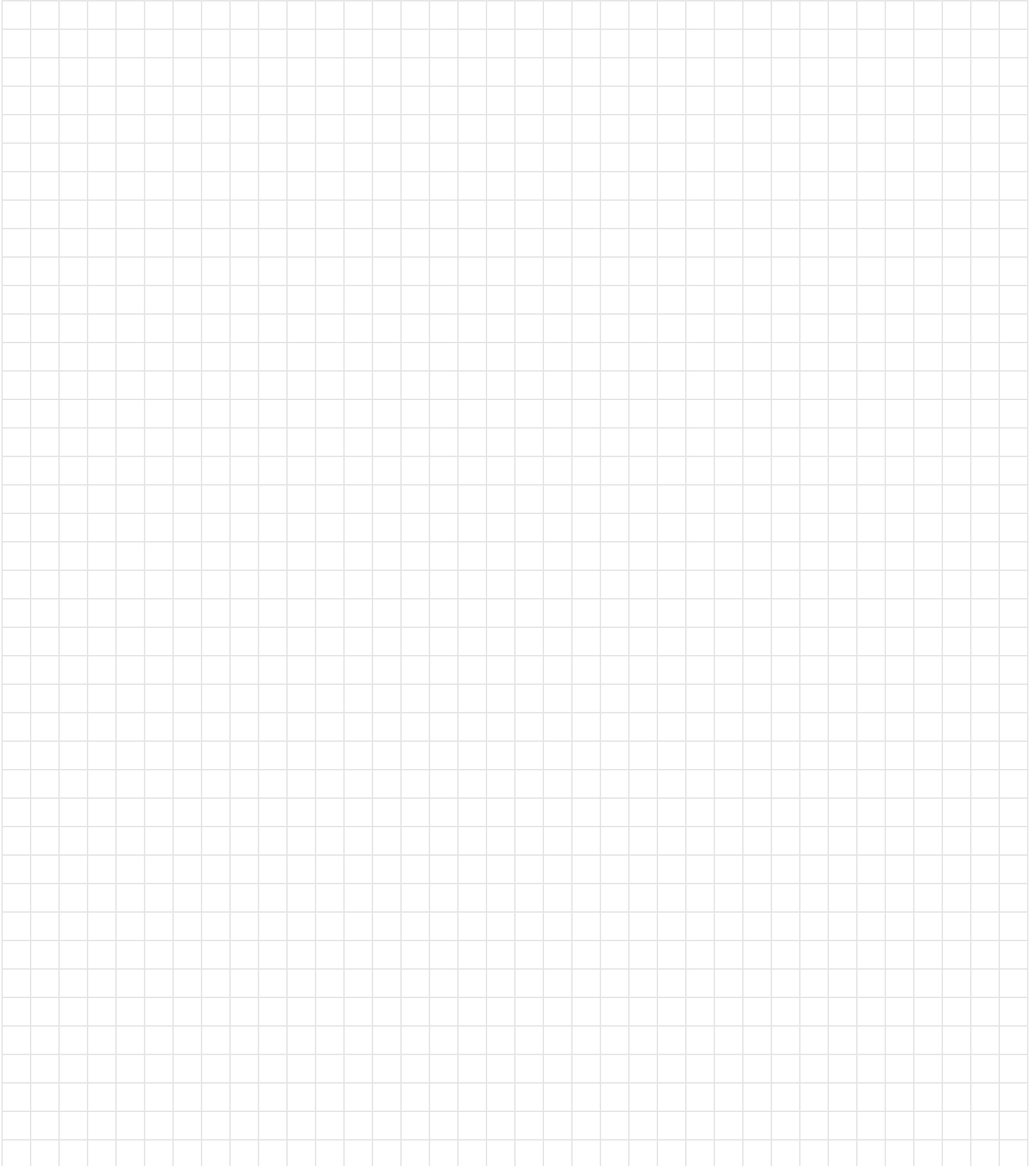



Pressure/Vacuum Relief Valve

Pilot-operated diaphragm valve

PROTEGO® PM/(D)S

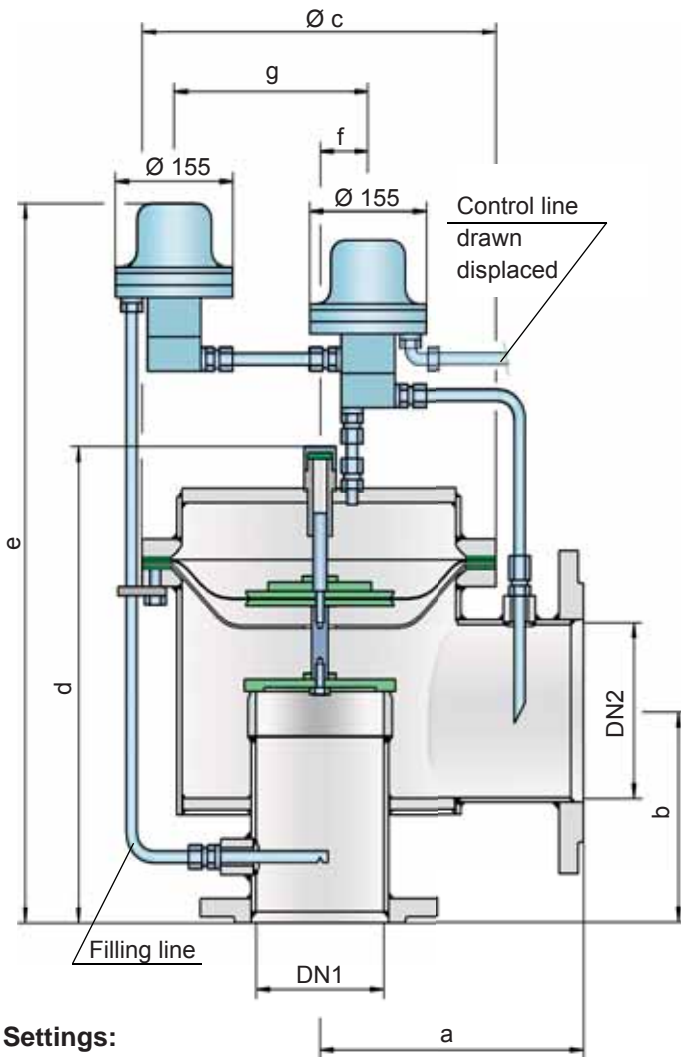

Settings:

Pressure: +10 mbar up to +300 mbar
+4 inch W.C. up to +120 inch W.C.

Vacuum: -3.0 mbar up to -7 mbar
-1.2 inch W.C. up to -2.8 inch W.C.

Higher or lower settings upon request.

Function and Description

The PM/(D)S type pilot-controlled PROTEGO® diaphragm valve is a highly developed valve for pressure and vacuum relief. It is primarily used as a safety device for outbreathing in tanks, containers, and process engineering equipment and it also offers reliable protection from vacuum and overpressure. It prevents the intake of air and unacceptable product vapor loss up to the set point. The valve can also be used as inbreathing valve. The main valve is directly controlled when it is exposed to a vacuum; e.g., it functions as a weight-loaded diaphragm valve. This valve is highly suitable under atmospheric conditions and for use in cryogenic service.

The main valve is controlled by a pilot valve. The pilot valve is controlled by the tank pressure. The tank medium does not continuously flow through the pilot. The set pressure is adjusted at the pilot valve by a corrosion-resistant and low-temperature-resistant permanent magnet.

As the operating pressure increases, the closing force acting on the main valve also rises; e.g. the valve tightness increases to prevent leakage until the set pressure is reached. After the valve responds, it immediately opens completely without any significant increase in pressure (pop open characteristic), and the nominal volumetric flow is discharged through a fully open valve. If this level is exceeded, the pressure increase follows the flow performance curve ($\Delta p/\dot{V}$ curve). Up to the set pressure, the tank pressure is maintained with a tightness that is far superior to the conventional standard due to the superior manufacturing technology. This feature is achieved by valve seats made of high-grade stainless steel with precisely ground valve pallets. After the excess pressure is discharged or the vacuum is compensated, the valve reseats and provides a tight seal.

Special Features and Advantages

- high degree of safety due to double pilot
- controlled by corrosion-resistant, low-temperature-resistant permanent magnet
- the tank medium does not continuously flow through the pilot valve
- pop-open characteristic from a minimum pressure rise to full lift
- extreme tightness and hence least possible product losses and reduced environmental pollution
- set pressure is close to full lift pressure, which results in high level of design freedom and product savings
- high flow capacity
- the control diaphragm of the main valve is shielded from low temperatures - high-level durability
- can be used in areas subject to an explosion hazard
- designed for use at low temperatures
- self draining

Design Types and Specifications

The valve is equipped with either a control pilot valve or with one control and emergency pilot valve to ensure optimum operating safety in case of malfunctions or damage.

Two different designs are therefore available:

Basic design of pressure/vacuum relief valve with a control pilot valve **PM/S-**

Basic pressure/vacuum relief valve with a control pilot valve and additional emergency pilot valve **PM/DS-**

Additional special devices available upon request.

Table 1: Dimensions

Dimensions in mm / inches

To select the nominal size (DN), use the flow capacity charts on the following pages

DN1	80 / 3"	100 / 4"	150 / 6"	200 / 8"	250 / 10"	300 / 12"	300 / 12"
DN2	100 / 4"	150 / 6"	200 / 8"	250 / 10"	300 / 12"	350 / 14"	400 / 16"
a	225 / 8.86	250 / 9.87	325 / 12.80	375 / 14.76	450 / 17.72	500 / 19.69	500 / 19.69
b	150 / 5.91	175 / 6.89	225 / 8.86	250 / 9.84	270 / 10.63	300 / 11.81	325 / 12.79
c	275 / 10.83	330 / 12.99	445 / 17.52	550 / 21.65	665 / 26.18	785 / 30.91	785 / 30.91
d	370 / 14.57	425 / 16.73	530 / 20.87	605 / 23.82	675 / 26.57	785 / 30.91	835 / 32.87
e	615 / 24.21	685 / 26.97	770 / 30.31	825 / 32.48	935 / 36.81	1005 / 39.57	1055 / 41.53
f	35 / 1.38	40 / 1.57	40 / 1.57	50 / 1.97	50 / 1.97	50 / 1.97	50 / 1.97
g	160 / 6.30	195 / 7.68	250 / 9.84	315 / 12.40	370 / 14.57	425 / 16.73	425 / 16.73

Table 2: Material selection for housing

Design	A	B	Special materials upon request
Housing	Aluminium	Stainless Steel	
Valve seat	Stainless Steel	Stainless Steel	
Sealing	KL-C-4106	KL-C-4106	
Main diaphragm protection	Stainless Steel	Stainless Steel	
Pilot lines	Stainless Steel	Stainless Steel	
Pilot housing	Stainless Steel	Stainless Steel	
Pilot diaphragm	FEP	FEP	

Table 3: Material selection for valve pallet

Design	A	B	C	Special materials upon request
Pressure range (mbar) (inch W.C.)	-3.0 up to -4.0* -1.2 up to -1.6*	-4.0 up to -5.0* -1.6 up to -2.0*	-5.0 up to -7.0* -2.0 up to -2.8*	
Valve pallet	Aluminium	Stainless Steel	Stainless Steel	
Diaphragm	FEP	FEP	FEP	
Diaphragm pallet	Aluminium	Aluminium	Stainless Steel	

* The indicated vacuum ranges depend on the nominal sizes and can differ.

The pressure setting can be combined with any vacuum setting

Table 4: Flange connection type

EN 1092-1, Form B1 or DIN 2501, Form C, PN 16; from DN 200 PN 10	EN or DIN	other types upon request
ANSI 150 lbs RFSF	ANSI	





Pressure/Vacuum relief valve

Flow Capacity Charts

PROTEGO® PM/(D)S

* = DN1 300/12" / DN2 350/14"

** = DN1 300/12" / DN2 400/16"

DN1 = DN

DN 80 / 3"

DN 100 / 4"

DN 150 / 6"

DN 200 / 8"

DN 250 / 10"

DN 300 / 12" *
DN 300 / 12" **

airflow in thousands of CFH

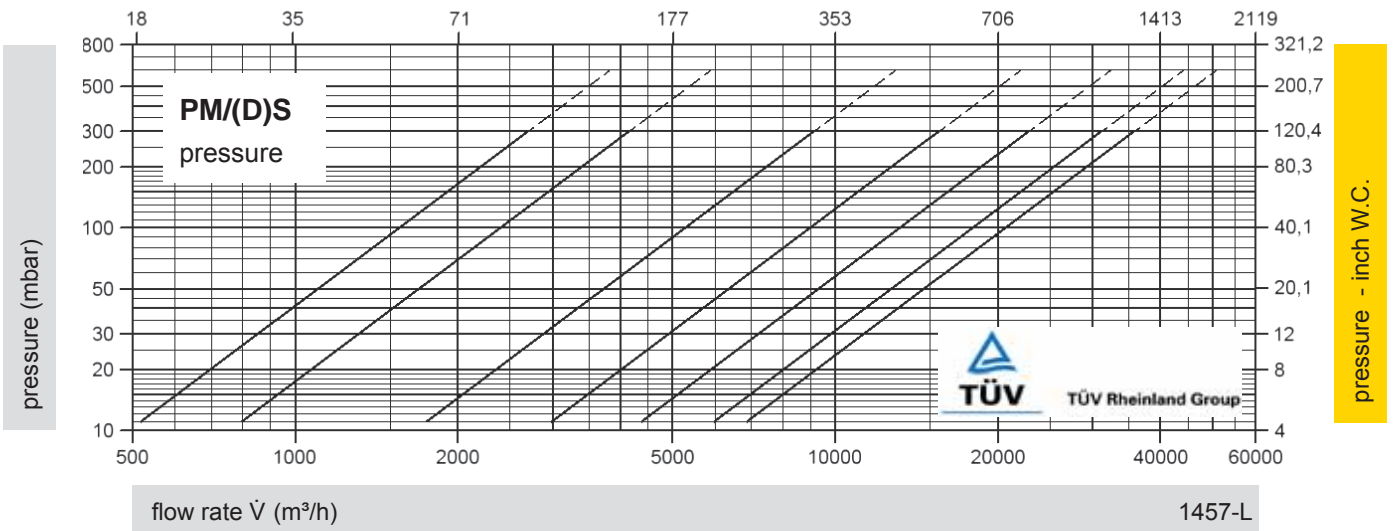

* = DN1 300/12" / DN2 350/14"

** = DN1 300/12" / DN2 400/16"

DN1 = DN

DN 80 / 3"

DN 100 / 4"

DN 150 / 6"

DN 200 / 8"

DN 250 / 10"

DN 300 / 12" *
DN 300 / 12" **

airflow in thousands of CFH

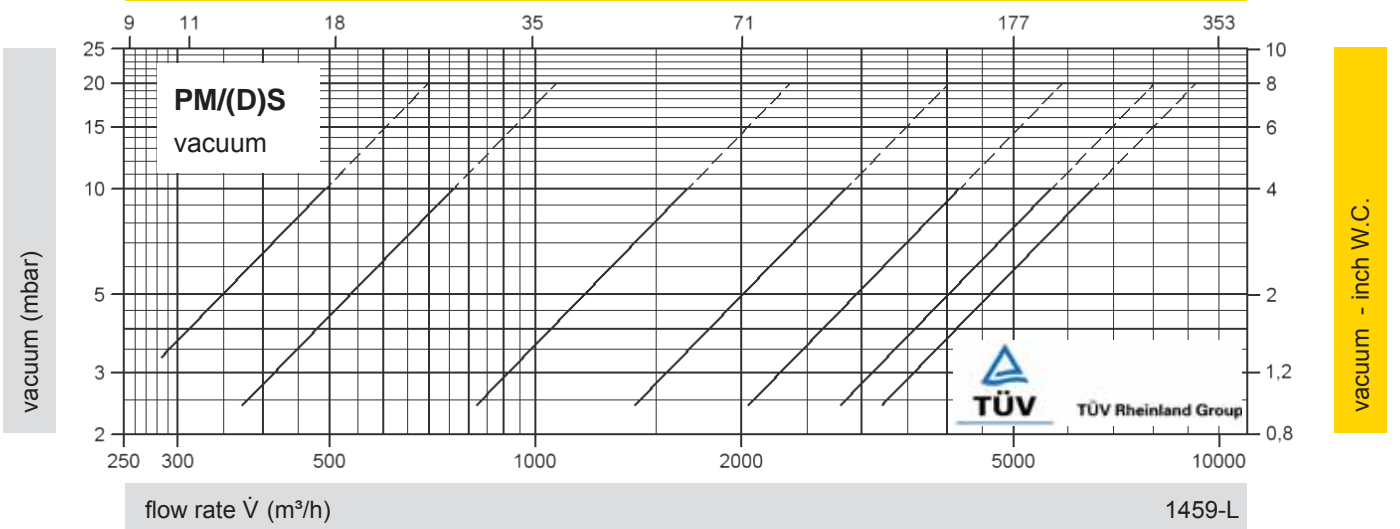

The flow capacity charts have been determined with a calibrated and TÜV certified flow capacity test rig. Volume flow \dot{V} in (m³/h) and CFH refer to the standard reference conditions of air ISO 6358 (20°C, 1bar). Conversion to other densities and temperatures refer to Vol. 1: "Technical Fundamentals".

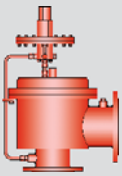

Pressure/Vacuum Relief Valve

Pilot-operated diaphragm valve

PROTEGO® PM-HF

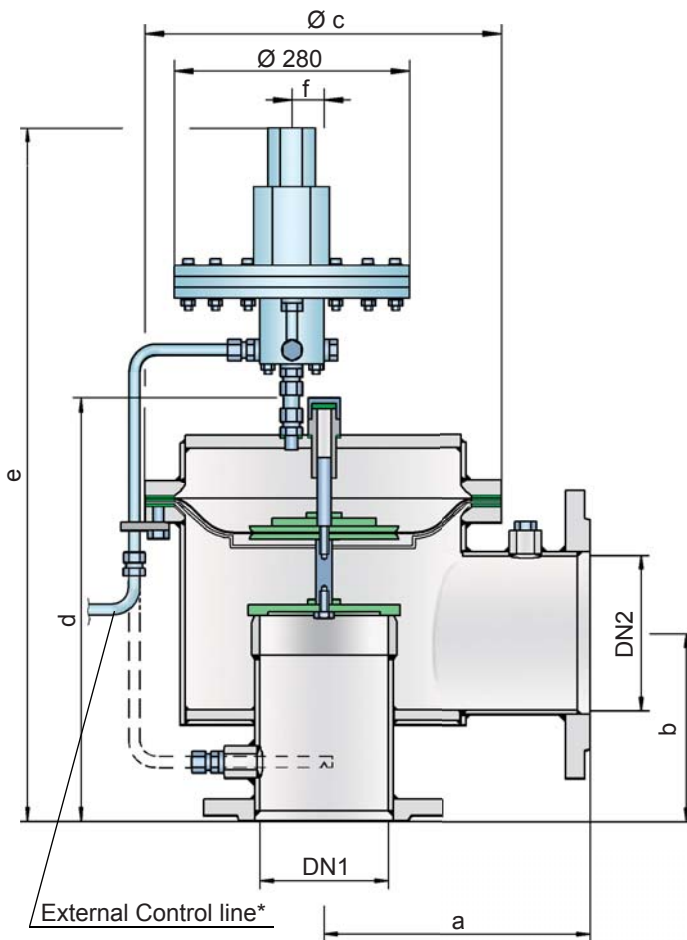

Settings:

Pressure: +10 mbar up to +1034 mbar
+4 inch W.C. up to +413.6 inch W.C.

Vacuum: -2.2 mbar up to -7 mbar
-0.88 inch W.C. up to -2.8 inch W.C.

Higher or lower settings upon request.

Function and Description

The PROTEGO® Type PM-HF pilot-controlled diaphragm valve is a highly developed valve for pressure and vacuum relief. Primarily used as a safety device for outbreathing in tanks, vessels, and process engineering equipment it also offers reliable protection from vacuum and overpressure. It prevents intake of air and unacceptable product vapor loss up to and until the set-to-operate pressure is reached. The valve can be used as an in-breathing device as well. In such an application, the main valve is directly controlled when exposed to a vacuum, i.e. it functions as a weight-loaded diaphragm valve.

The main valve is controlled by a pilot valve. The latter in turn is controlled by the tank pressure. A small amount fluid stored in the tank released into the atmosphere by the pilot when the valve opens. The set-to-operate pressure is adjusted on the pilot valve by increasing or decreasing (as appropriate) the tension of a spring.

As the working pressure rises, the closing force acting on the main valve increases, i.e. the valve's tight-sealing is enhanced until the set-to-operate pressure is reached, thus preventing leakage. Once the valve has commenced to lift it opens fully within a 10% pressure rise or the opening pressure difference and the nominal volumetric flow is discharged through a fully open valve. If and when this level is exceeded the pressure increase will follow the performance curve ($\Delta p/\dot{V}$ curve). The vacuum venting function is only meant as emergency ventilation. From set pressure to full capacity (fully open valve) the pressure increase is c. 40% in case of vacuum. Due to the sophisticated manufacturing technology, the tank pressure is maintained up to the set-to-operate pressure, with seal-tight requirements far above common standards being met. This feature is achieved through valve seats made of high-grade stainless steel with precisely ground valve pallets. Once the excess pressure is relieved or pressure below atmospheric balanced out, the valve reseats and seals tight again.

Special Features and Advantages

- controlled by corrosion-resistant pilot valve
- no continuous flow of fluid stored in the tank, through the pilot valve
- small amount fluid stored in the tank released into the atmosphere by the pilot when the valve opens
- 4%-10% Technology for minimum pressure increase until full lift
- seals extremely tight; hence, least possible product losses and reduced impact on the environment
- set-to-operate pressure close to the opening pressure; hence, best possible pressure management of the system.
- control diaphragm of the main valve shielded from low temperatures - Long service life
- high flow capacity
- suited for use in hazardous areas
- Automatic condensate drain
- Rugged and improved valve design

Design Types and Specifications

Basic design of pressure/vacuum relief valve with a **PM-HF** control pilot valve

Additional special devices available upon request.

* It is recommended that an external control line be provided with direct connection to the tank.

Table 1: Dimensions

Dimensions in mm / inches

To select the nominal size (DN), use the flow capacity charts on the following pages

DN1	80 / 3"	100 / 4"	150 / 6"	200 / 8"	250 / 10"	300 / 12"	300 / 12"
DN2	100 / 4"	150 / 6"	200 / 8"	250 / 10"	300 / 12"	350 / 14"	400 / 16"
a	225 / 8.86	250 / 9.87	325 / 12.80	375 / 14.76	450 / 17.72	500 / 19.69	500 / 19.69
b	150 / 5.91	175 / 6.89	225 / 8.86	250 / 9.84	270 / 10.63	300 / 12.81	300 / 12.81
c	275 / 10.83	330 / 12.99	445 / 17.52	550 / 21.65	665 / 26.18	785 / 30.91	785 / 30.91
d	370 / 14.57	425 / 16.73	515 / 20.28	590 / 23.23	675 / 26.57	785 / 30.91	785 / 30.91
e	763 / 30.04	770 / 30.31	923 / 36.34	977 / 38.46	1032 / 40.63	1148 / 45.20	1198 / 47.17
f	35 / 1.38	40 / 1.57	40 / 1.57	50 / 1.97	50 / 1.97	50 / 1.97	50 / 1.97

Table 2: Material selection for housing

Design	A	B	Special materials upon request
Housing	Aluminium	Stainless Steel	
Valve seat	Stainless Steel	Stainless Steel	
Sealing	KL-C-4106	KL-C-4106	
Main diaphragm protection	Stainless Steel	Stainless Steel	
Pilot lines	Stainless Steel	Stainless Steel	
Pilot housing	Aluminium	Aluminium / Stainless Steel	
Pilot diaphragm	FEP	FEP	

Table 4: Flange connection type

EN 1092-1, Form B1 or DIN 2501, Form C, PN 16; from DN 200 PN 10	EN or DIN	other types upon request
ANSI 150 lbs RFSF	ANSI	



for safety and environment

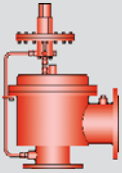

Pressure/Vacuum relief valve

Flow Capacity Charts

PROTEGO® PM-HF

* = DN1 300/12" / DN2 350/14"
 ** = DN1 300/12" / DN2 400/16"

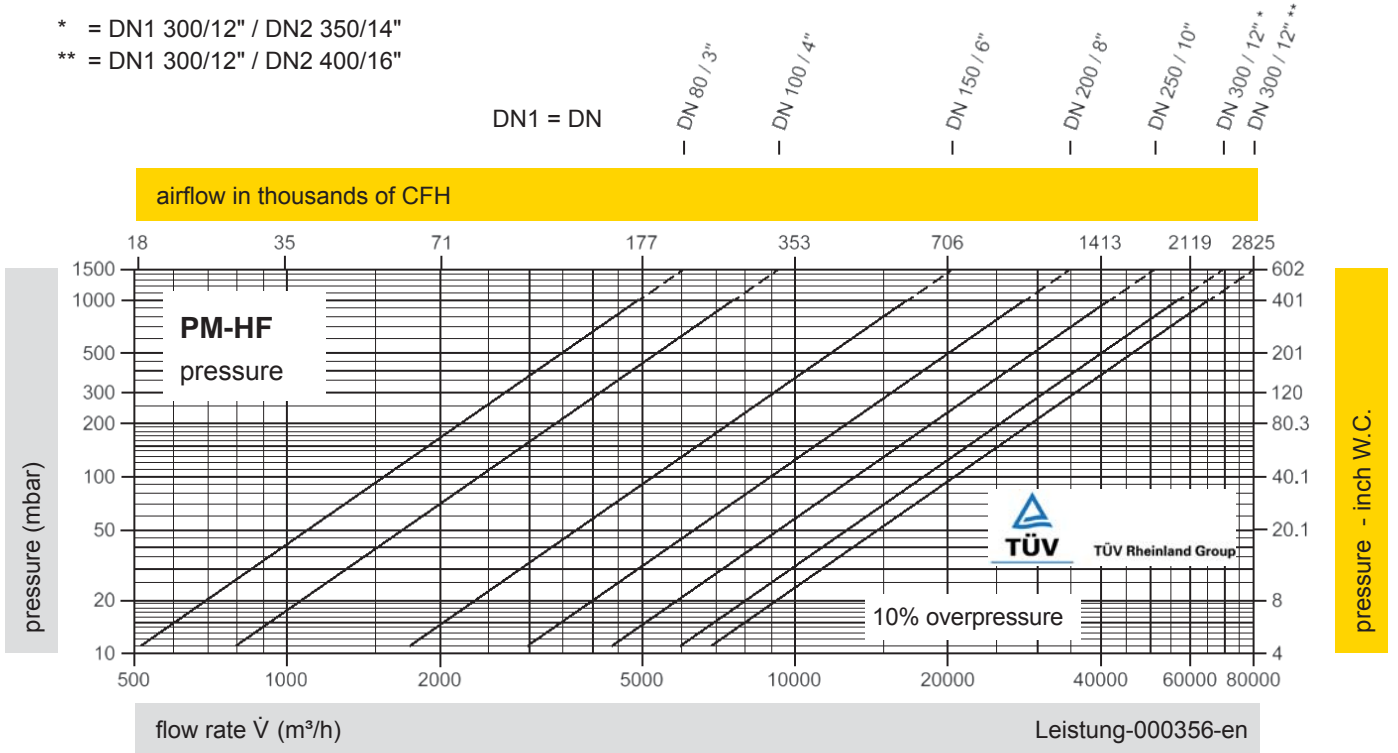

* = DN1 300/12" / DN2 350/14"
 ** = DN1 300/12" / DN2 400/16"

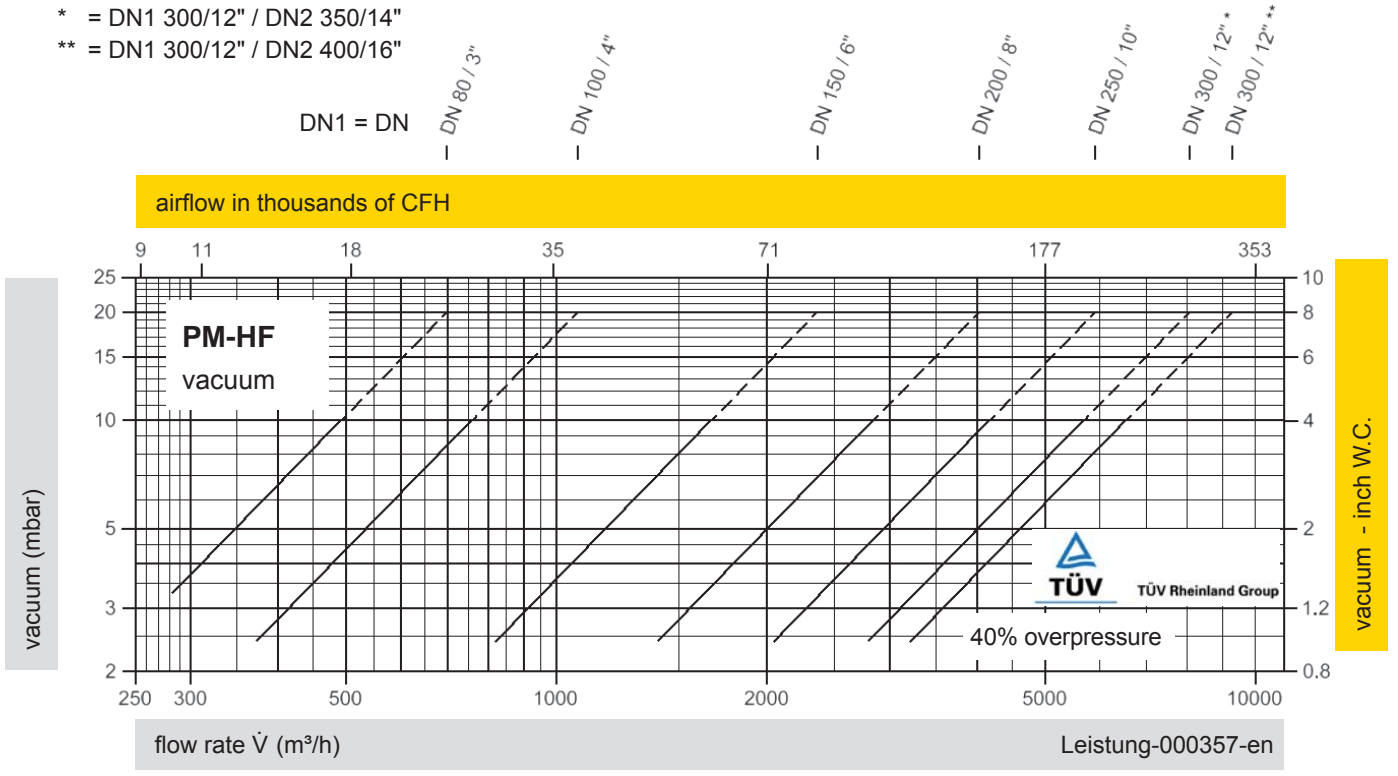

The flow capacity charts have been determined with a calibrated and TÜV certified flow capacity test rig. Volume flow \dot{V} in (m³/h) and CFH refer to the standard reference conditions of air ISO 6358 (20°C, 1bar). Conversion to other densities and temperatures refer to Vol. 1: "Technical Fundamentals".

Table5: Coefficient of Discharge

DN1	80 / 3"	100 / 4"	150 / 6"	200 / 8"	250 / 10"	300 / 12"	300 / 12"
DN2	100 / 4"	150 / 6"	200 / 8"	250 / 10"	300 / 12"	350 / 14"	400 / 16"
d0	81 / 3.19	107 / 4.21	160 / 6.30	208 / 8.19	260 / 10.24	310 / 12.20	310 / 12.20
K	0.68	0.60	0.59	0.59	0.56	0.53	0.61
K _{dr} 90%	0.61	0.54	0.53	0.53	0.50	0.48	0.55
K _{dr} 95%	0.65	0.57	0.56	0.56	0.53	0.50	0.58

DN1 = Size Inlet
DN2 = Size Outlet
d0 = Orifice Diameter (mm / inches)
K = Coefficient of Discharge
K_{dr} = Derated Coefficient of Discharge

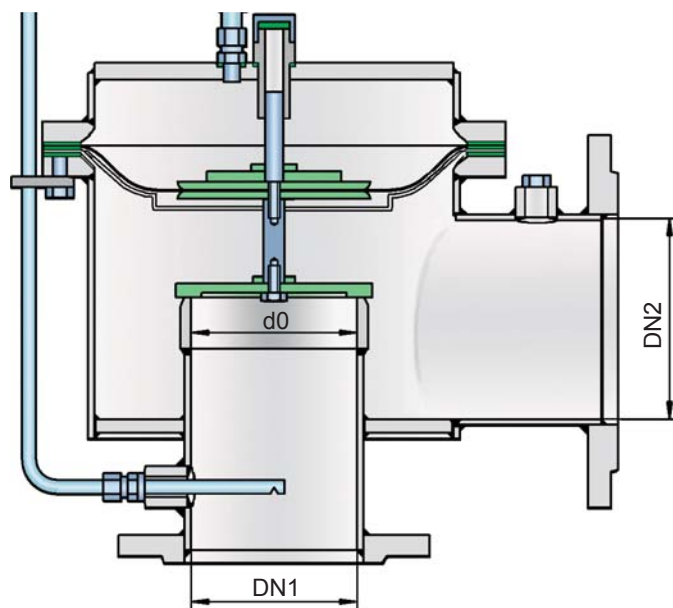

www.protego.de



for safety and environment