

Type 859/554

CE-0085B00366 / CE-0085B00364



The pressure regulator combination type 859/554 is a combination of a regulator of 1st stage and a regulator of 2nd stage, which reduces the non-regulated pressure from the cylinder bundle or tank to a fixed outlet pressure. An overpressure shut-off (OPSO) of 1st stage and a relief valve of 2nd stage are incorporated into the regulator to provide safety against overpressure in the regulator combination/installation.

1st and 2nd stage can be delivered separately.
Placing of vents: see pages 53-54

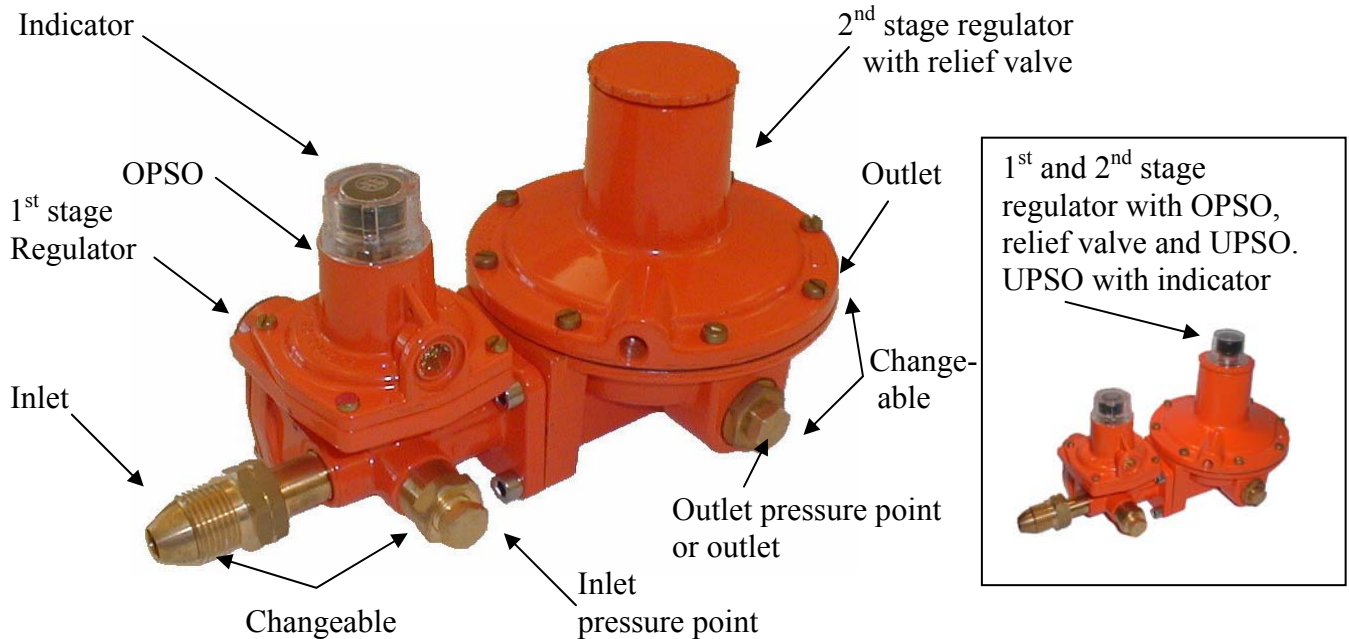

Bracket can be delivered, but is not standard – see page 55
Resetting tool for OPSO is not standard, but can be delivered – see page 54.
The regulator combination can be delivered with inlet and outlet connections on the side.
The regulator combination can be equipped with an under pressure shut-off (UPSO) with an indicator.
The activation pressure is shown in the table at the next page.

<p>Type 859 with OPSO CE-0085B00366 Other approvals on request. Pressure stage..... PN 25 Nominal capacity: 10 kg/h LPG Inlet pressure:..... pd+1 - 16 bar (pd+0.1-1.6 MPa) Outlet pressure pd: 2 bar (0.2 MPa) Temperature range -20°C to +50°C Inlet: POL-connection (EN 13785) Outlet: Connected to 2nd stage regulator</p>	<p>Type 554 with relief valve and with / without OPSO CE-0085B00364 Other approvals on request. Pressure stage PN 4 Nominal capacity:..... 12 / 24 kg/h LPG Inlet pressure: up to 4 bar (up to 0.4 MPa) Outlet pressure pd:..... 29; 37; 50; 67 mbar (2.9; 3.7; 5.0; 6.7 kPa) Temperature range..... -20°C to +50°C Inlet: Connected to 1st stage regulator Outlet: Rp½"</p>
<p>Can be delivered with a relief valve as 1st safety device and OPSO as 2nd safety device against overpressure or the reverse. (see next page)</p>	<p>Can be delivered with a relief valve as 1st safety device and OPSO as 2nd safety device against overpressure or the reverse. (see next page)</p>
<p>Other pressures on request.</p>	<p>Other inlet and outlet connections on request.</p>

Can be delivered as a natural gas pressure regulator. Please contact us as to the norm basic, pressure and capacity.

Mode of operation

The regulator combination reduces the non-regulated pressure from the cylinder bundle or the tank to nominal 29; 37; 50 or 67 mbar (2.9; 3.7; 5.0; 6.7 kPa). Or on request.

At an inadmissible rise of the outlet pressure of the 2nd stage regulator the OPSO closes the gas flow on the inlet side of the regulator combination and the indicator turns red. At continued rise of the outlet pressure of the 2nd stage regulator, the relief valve opens and releases a limited quantity of gas to the atmosphere. The relief valve closes automatically, relieving the overpressure. The OPSO has to be reset manually.

The regulator combination can be delivered with a relief valve as 1st safety device and the OPSO as 2nd safety device. Examples of numbering of the regulator combinations/safety device: see page 57

to be continued on next page.

Type 859/554

CE-0085B00366 / CE-0085B00364



1st stage regulator.

Outlet pressure of the regulator type 859 compared to inlet pressure and capacity.

Nominal outlet pressure	Minimum outlet pressure	Maximum outlet pressure	Maximum lock-up pressure	Inlet pressure range	Capacity LPG
1 bar	0.7 bar	1.2 bar	1.2 bar	2-16 bar	10 kg/h
2.5 bar	2.13 bar	2.88 bar	2.88 bar	3.5-16 bar	10 kg/h
0.1 MPa	0.07 MPa	0.12 MPa	0.12 MPa	0.2-1.6 MPa	10 kg/h
0.25 MPa	0.213 MPa	0.288 MPa	0.288 MPa	0.35-1.6 MPa	10 kg/h

2nd stage regulator.

Outlet pressure of the regulator type 554 compared to inlet pressure and capacity.

Nominal outlet pressure	Minimum outlet pressure	Maximum outlet pressure	Maximum lock-up pressure	Inlet pressure range	UPSO closing pressure	Capacity LPG
29 mbar	27 mbar	35 mbar	40 mbar	0.5 – 4 bar	25 mbar	12 kg/h
37 mbar	27 mbar	45 mbar	50 mbar	0.5 - 4 bar	25 mbar	24 kg/h
50 mbar	47.5 mbar	57.5 mbar	62.5 mbar	1 – 4 bar	40 mbar	12 kg/h
67 mbar	55 mbar	80 mbar	85 mbar	0,5 – 4 bar	50 mbar	24 kg/h
2.9 kPa	2.7 kPa	3.5 kPa	4 kPa	0.05 - 0.4 MPa	2.5 kPa	12 kg/h
3.7 kPa	2.7 kPa	4.5 kPa	5 kPa	0.05 - 0.4 MPa	2.5 kPa	24 kg/h
5 kPa	4.75 kPa	5.75 kPa	6.25 kPa	0.1 - 0.4 MPa	4 kPa	12 kg/h
6.7 kPa	5.5 kPa	8 kPa	8.5 kPa	0.05 - 0.4 MPa	5 kPa	24 kg/h

Safety device activated by the outlet pressure of the 2nd stage regulator.

Nominal outlet pressure 2 nd stage:	OPSO(at the 859):	Relief valve (incorporated in 554) :
29 mbar (2.9 kPa)	100 mbar (10 kPa) *)	130 mbar (13 kPa) **)
37 mbar (3.7 kPa)	100 mbar (10 kPa) *)	130 mbar (13 kPa) **)
50 mbar (5 kPa)	100 mbar (10 kPa) *)	130 mbar (13 kPa) **)
67 mbar (5kPa)	130 mbar (13 kPa) *)	150 mbar (15 kPa) **)
29 mbar (2.9 kPa)	130 mbar (13 kPa) **)	100 mbar (10 kPa) *)
37 mbar (3.7 kPa)	130 mbar (13 kPa) **)	100 mbar (10 kPa) *)
50 mbar (5 kPa)	130 mbar (13 kPa) **)	100 mbar (10 kPa) *)
67 mbar (5kPa)	150 mbar (15 kPa) **)	130 mbar (13 kPa) *)

*) = first activated

***) = second activated

Example of installation.

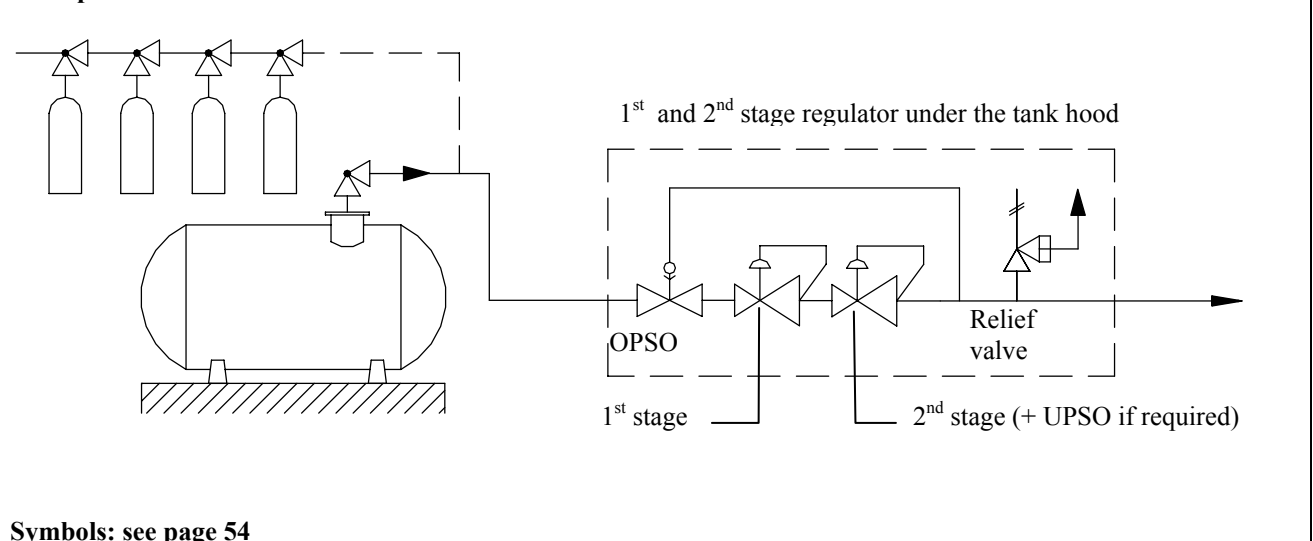

Symbols: see page 54

During installation, commissioning and functional testing of the regulator combination please note the instructions on pages 31 + 32 !